

efi sales Ltd.

Equipment for the Foodservice Industry

value + quality + service

HOT DISPLAY CASE COUNTERTOP

48x26"

HCGS-CT-4826



HCGS-CT-4826

Features

Features:

- Brilliant internal LED illumination on top
- Adjustable temperature controller
- Temperature display
- Adjustable chrome plated shelves
- Front and back sliding doors

Warranty:

- One year limited warranty parts and labour.
For full warranty details visit <https://www.efifoodequip.com/warranty-info.php>



HCGS-CT-4826

Specifications

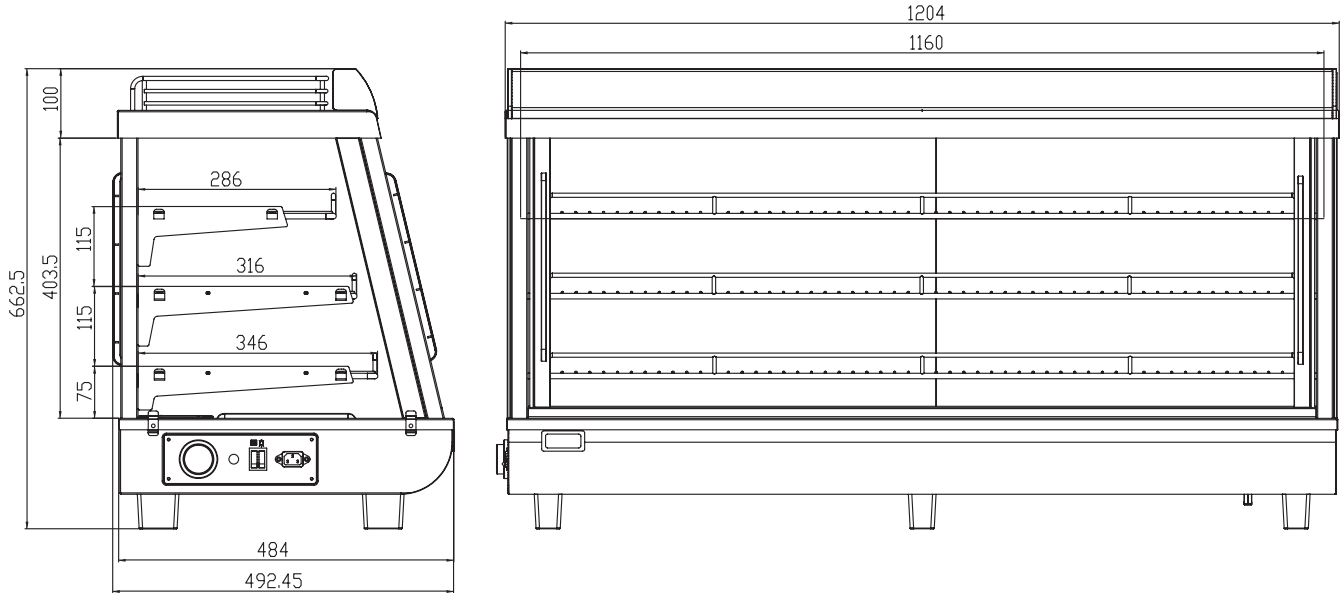

Model	Dimension (mm / inch)			Voltage	Amps	Capacity (L / Cu Ft.)	Net Weight (KG / LBS)	Temperature Range
	L	D	H					
HCGS-CT-4826	1214.5	484	662.5	115/60	12.8	186	53.5	30-90°C
	47.8	19.1	26.1			6.6	117.7	86-194°F

Equipped with one NEMA 5-15P plug 

Specifications subject to change without notice.