

# NOM-36-LSB

## GRAB 'N GO

# OPEN MERCHANDISERS

Ideal for restaurants, cafés, convenience stores and supermarkets



## FEATURES



Pull-down night curtain



Tempered glass

4 staging shelves

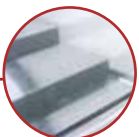

Stainless-steel black-brushed exterior

Cool tone LED lighting



Front-facing condenser with easy-to-clean filter

Magnetized front panel for quick removal

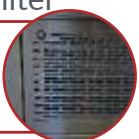

Digital temperature control  
w/ separate light switch



## ADDITIONAL FEATURES

- ✓ Front to rear ventilation with back stoppers for better air circulation
- ✓ 4 heavy duty casters with 1 front leg 
- ✓ Anti-corrosion coated evaporator
- ✓ Inner cabinet insulated with high-density polyurethane foam
- ✓ Auto-defrost system
- ✓ Absorbent wicking pad to manage the excess water



# SPECIFICATIONS

Capacity (Cubic Feet)	5.08
Capacity (Litres)	144
Exterior Unit Dimensions (in)	35.4" (w) x 33.5" (d) x 41.3" (h)
Interior Dimensions (in)	32.23" (w) x 28" (d) x 16" (h)
Net / Gross Weight (lb)	288.8 / 374.78
Night Curtain	Yes
Swivel Casters	4 casters
Front Support Leg	1
Adjustable Shelves	4 staging shelves
Shelf Dimensions	2 X 16" w x 15" d 2 X 16" w x 7.5" d
Shelf Capacity (lb)	80
Temperature	2-5°C
Ambient Temperature	<24°C
Ambient Humidity	55%
Refrigerant (CFC-Free)	R290
Input Power	897 W
Voltage	115V/60H/1PH
Amperage	7.8
Plug Type	5-15P

TOP VIEW

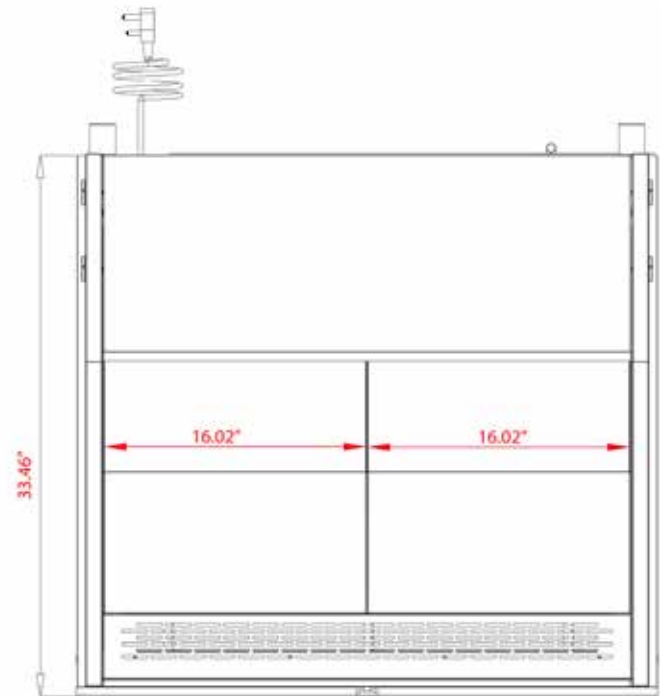

SIDE & INTERIOR VIEW



NEMA 5-15P

REAR VIEW

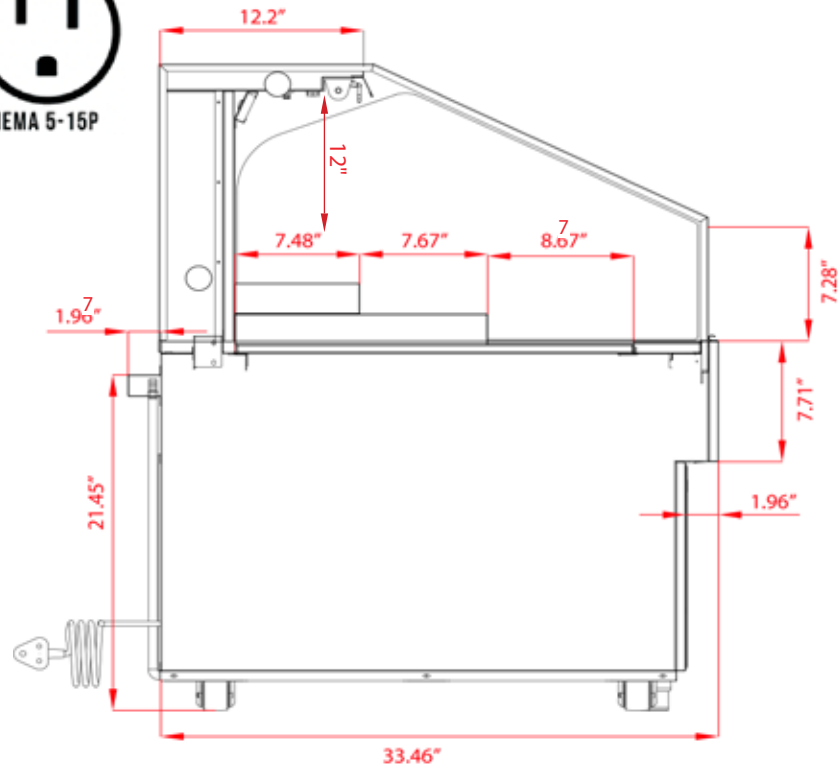
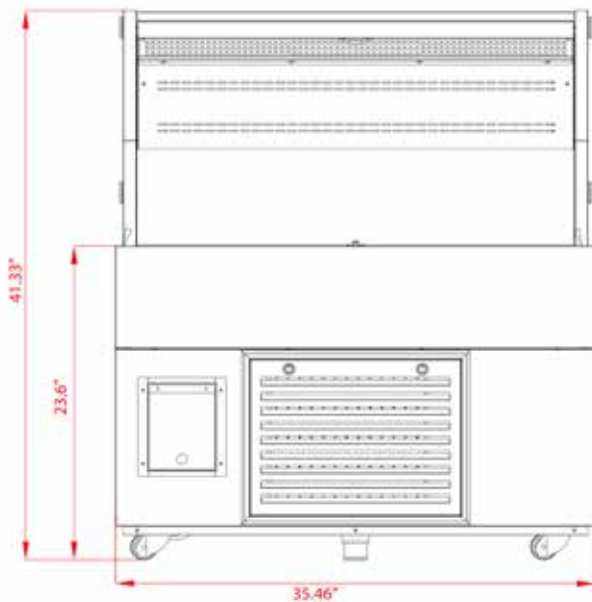

CUSTOMER SUPPORT



We're on social media!  
1.800.567.3620



[www.newairrefrigeration.ca](http://www.newairrefrigeration.ca)

MORE PRODUCTS!



Design and specifications can change without prior notice for product improvement