

CHEST FREEZER

NIF-80-CG



FEATURES



699.5 L capacity / 24.7 cubic ft.



Front protective bumper bar



Temperature range (°C) : (-18) - (-13)



Adjustable temperature control



Anti-fogging tempered glass



Lock and key included



Sliding glass doors for easy viewing and access of products



Six wire baskets included

Distributed by:



SPECIFICATIONS

Capacity (Cubic Feet)	24.7
Capacity (Litres)	699.5
Exterior Unit Dimensions (in)	79.75" (w) x 29.5" (d) x 33" (h)
Exterior Unit Dimensions (cm)	202.5 (w) x 75 (d) x 84 (h)
Shipping Dimensions with Box (in)	81.75" (w) x 31.5" (d) x 34.5" (h)
Shipping Dimensions with Box (cm)	206 (w) x 80 (d) x 88 (h)
Net Weight	256lbs (116 kg)
Baskets Included	6
Basket Size	11" (w) x 21.5" (d) x 6" (h)
Voltage	115V/60Hz
Input Power	450W
Amperes	4.5
Temperature	(-18) - (-13) °C
Refrigerant (CFC-Free)	R290
Plug Type	Nema 5-20P



Warranty 2 years parts and labour,
3 additional years on the compressor

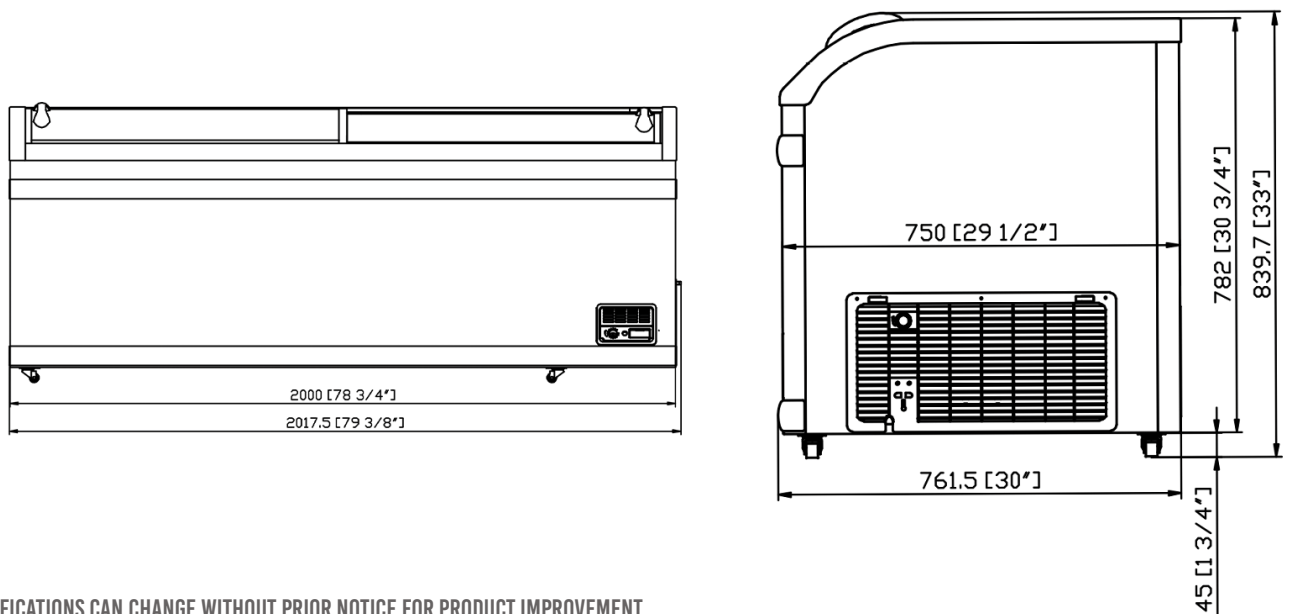

DESIGN AND SPECIFICATIONS CAN CHANGE WITHOUT PRIOR NOTICE FOR PRODUCT IMPROVEMENT

CUSTOMER SERVICE: 1.800.567.3620