



Equipment for the Foodservice Industry

value + quality + service

## X-LINE Mega Top Prep Tables

CMDR1-27VCX



### CMDR1-27VCX Features

Features:

- Stainless steel interior and exterior
- Round corner design for inner bottom board
- Polyethylene cutting board
- Self-closing swing door w/90°stay open feature
- Recessed handles
- Removable gasket that is easy to clean and replace
- Adjustable/removable plastic coated wire shelves
- Enclosed condiment section
- R290 refrigeration system holds 33°F to 41°F (0.5°C to 5°C)
- Insulated lid on prep units helps to maintain food freshness
- Casters for easy movement
- Adjustable temperature set point and defrost frequency
- Error codes to diagnose service issues
- Condenser access at rear of unit, slides out for easy maintenance

Warranty:

- Two year parts and labour; Five years on compressor. For full warranty details visit <https://www.efifoodequip.com/warranty-info.php>



**CMDR1-27VCX Specifications**

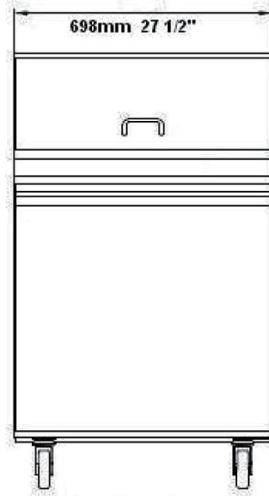

Elevation

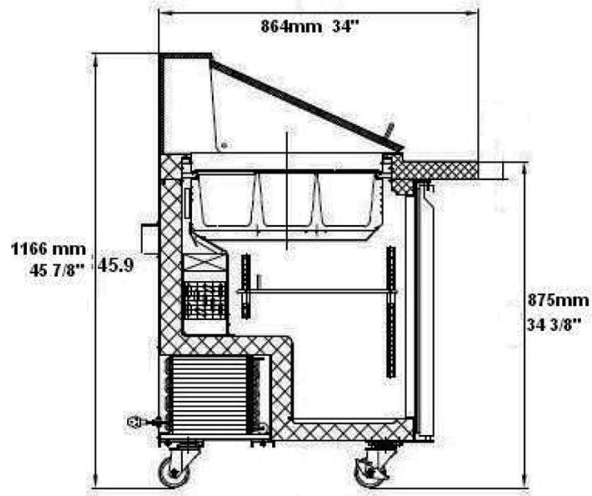

Section View

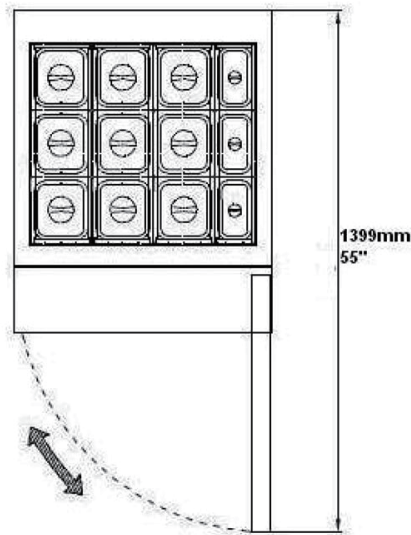

Plan

Model	Doors	Shelves	Dimension (mm) (inch)			HP	Voltage	Amps	Capacity (L) (Cu Ft.)	Net Weight (KG) (LBS)	NEMA Config.
			L	D	H						
CMDR1-27VCX	1	1	698	864	1166	2/5	115/60/1	3.6	160	89.8	5-15P
			27.5	34	45.9						

Specifications subject to change without notice.