

efi sales Ltd.

Equipment for the Foodservice Industry
value + quality + service

COUNTERTOP GLASS DOOR REFRIGERATOR

C1-52GDCT



C1-52GDCT

Features

Features:

- 52 L countertop display refrigerator
- Tempered glass door for maximum product visibility
- Black exterior with white interior
- Digital temperature control
- Adjustable temperature range between 0°C - 10°C

- LED interior lighting
- Adjustable shelf

Warranty:

- One year parts and labour; Five years on compressor. For full warranty details visit <https://www.efifoodequip.com/warranty-info.php>



C1-52GDCT Specifications

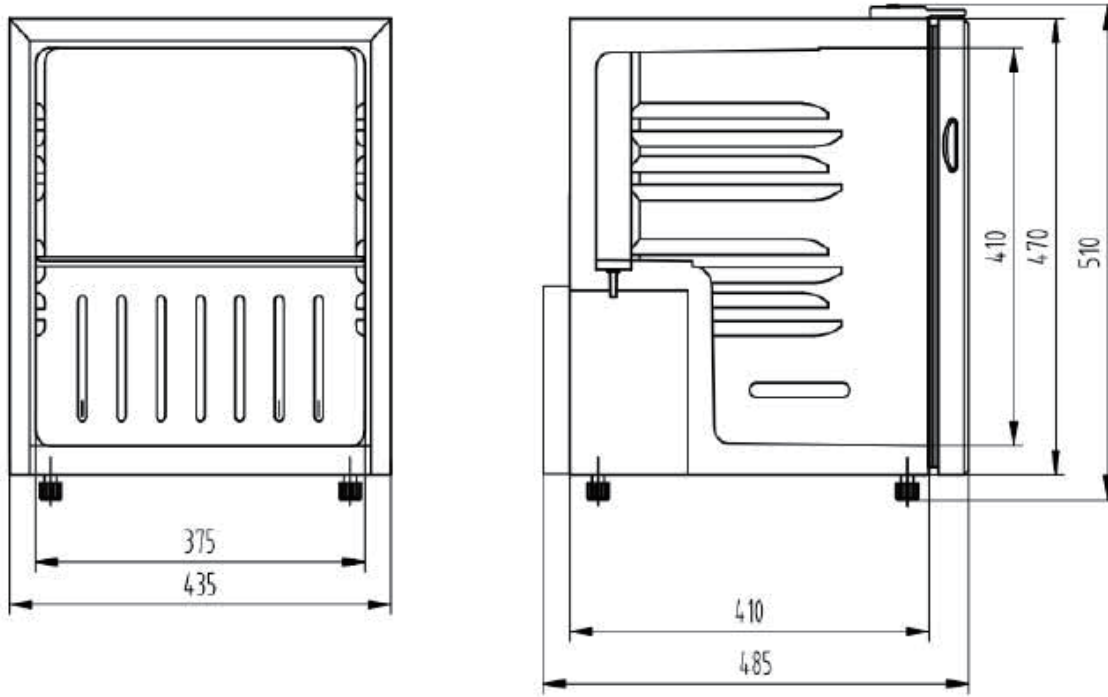

Model	Refrigerant	Door Type	Shelves	Dimension (mm / inch)			Voltage	Power	Capacity	Net Weight (KG / LBS)	Temperature Range
				W	D	H					
C1-52GDCT	R600a	Swing	1	435	500	510	110/60	80 W	52 L	19.5	0 ~ 10°C
				13.8	16.5	20.1				43	32 ~ 50°F

Equipped with one NEMA 5-15P plug 

Shipping Information

Crate Dimensions (mm / inch)			Net Weight (KG / LBS)	Gross Weight (KG / LBS)
W	D	H		
469	531	536	19.5	21
18.5	20.9	21.1	43	46.3

Specifications subject to change without notice.