



Prodigi™ 20-10 Combi Ovens

Gas and Electric

Prodigi™ Pro

Prodigi™ Classic



Manufacturer's Information

Copyright

© Copyright 3/24 by Alto-Shaam, Inc.
 All rights reserved.
 This manual or any portion thereof may not be reproduced or used in any manner whatsoever without the express written permission of Alto-Shaam, Inc

Trademarks

All trademarks referenced in this documentation are the property of their respective owners.

Manufacturer

Alto-Shaam, Inc.
 P.O. Box 450
 W164 N9221 Water Street
 Menomonee Falls, WI 53052

Models Covered

20-10E/G Classic and Pro	Electric and Gas Models US (UL Certified) Models International (CE Certified) Models
---------------------------------	--

Serial Number

The unit serial number is required for identifying and ordering the correct service parts.
 Record the unit serial number below for reference.

Serial Number

Parts Finder Tool

Interactive diagrams from this Parts Manual are available online at our Parts Finder Tool:
<https://www.alto-shaam.com/en/customer-support/parts>.
 Or, scan the QR code below.



Parts Ordering Information

Original manufacturer's replacement parts may be ordered directly from the Alto-Shaam network of Authorized Service Agents and Parts Distributors. Follow this link for a map to a local partner: <https://www.alto-shaam.com/en/how-to-buy>. If you are an Authorized Service Agent or Parts Distributor, please submit your purchase order to parts@alto-shaam.com.

Non-OEM parts may be substituted; however, these parts must be of equal quality and specifications as those provided by Alto-Shaam.

Table of Contents

Manufacturer's Information.....	2	Electrical Chassis, E, 208-240V 3PH SX 20-10—Relay Board Detail	44
Table of Contents.....	3	Electrical Chassis, E, 208-240V 3PH SX 20-10—Panel Detail.....	45
External Fasteners, Electric	4	Heating Element Package, 230V.....	46
External Fasteners, Gas.....	5	Preheat Strip Assembly.....	47
Outer Casing Package, 20-10	6	Smoker Box Package, 120V.....	48
Core Package, RH, 20-10.....	7	Smoker Box Package, 208V-380V	49
Core Package, RH, 20-10 (rear view).....	8	Non-Smoker Box Assembly.....	50
Side Panel Assembly, RH Door	9	Probe Package, Detachable, 20-10 and 20-20	51
Top Panel Weldment	10	Probe Plug Package	52
Cover Assembly, 20-10.....	11	Turbo Option Kits (all models).....	53
Door Service Kit, 20-10.....	12	Motor Assembly, Classic 110-130V.....	54
Middle Glass Door Assembly, 20-10	13	Motor Assembly, Classic 200-240V.....	55
Drip Tray Service Kits (all models).....	14	Motor Assembly, Pro.....	56
Directional Panel Assemblies (all models).....	15	Solenoids and Fans, 120V, 20-10 and 20-20.....	57
Gas Package, 20-10, 120V 30KW	16	Solenoids and Fans, 208-440V, 20-10 and 20-20	58
Gas Package, 20-10, 120V 30KW (detail view)	17	Pan Trolley, 20-10	59
Gas Conversion Kits.....	18		
Gas Valve Orifices	19		
Plumbing and Hoses, 20-10.....	20		
Grease Collection Package (no grease collection).....	21		
Grease Collection Package, 120V.....	22		
Grease Collection Package, 230V.....	23		
Grease Collection Package, 208-240V	24		
Liquid Cleaning Package.....	25		
Hose Package, Liquid Soap Injection	26		
No Liquid Soap Injection Package	27		
Service Kit, N6 Temperature Sensor.....	28		
Service Kit, Pro, Ampire Display.....	29		
Service Kit, Classic Display	30		
Service Kit, Control Board, DC.....	31		
Service Kit, Relay Board.....	32		
Service Kit, Option Board	33		
Electrical Chassis, G, 120V DX 20-10	34		
Electrical Chassis, G, 120V DX 20-10—Relay Board Assembly.....	35		
Electrical Chassis, G, 120V DX 20-10—Panel Assembly.....	36		
Electrical Chassis, G, 120V SX 20-10.....	37		
Electrical Chassis, G, 120V SX 20-10—Relay Board Assembly	38		
Electrical Chassis, G, 120V SX 20-10—Panel Assembly	39		
Electrical Chassis, E, 208-240V DX 20-10	40		
Electrical Chassis, E, 208-240V DX 20-10—Relay Board Detail	41		
Electrical Chassis, E, 208-240V DX 20-10—Panel Detail	42		
Electrical Chassis, E, 208-240V 3PH SX 20-10.....	43		

External Fasteners, Electric

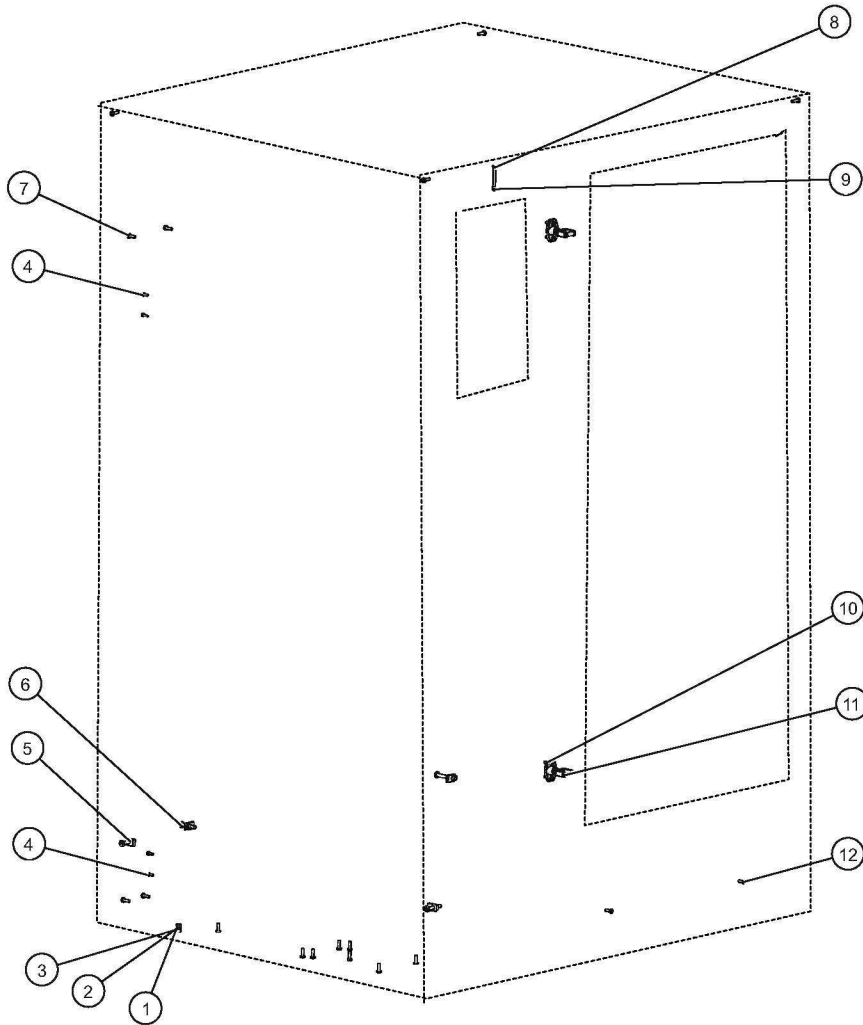

ID	Part No.	Description	Qty
1	WS-22297	WASHER, FLAT	2
2	NU-22291	M6-1.0 X HEX S/S NUT 18-8	2
3	WS-22302	WASHER, M6 SPLIT LOCK	2
4	SC-37702	SCREW, M4 X 12MM SEMS	4
5	NU-24004	NUT, U-STYLE 1/4-20 THREADED	4
6	SC-39832	SCREW, 1/4-20X1 1/2", PAN	4
7	SC-47718	SCREW, M5 X 16MM SEMS	16
8	SC-35259	SCREW, M5x0.8X50MM FLAT	1
9	NU-35233	NUT, M5 DOMED	1
10	SC-38487	SCREW, M5x0.8X20MM PAN	4
11	BP-38451	LATCH, ADJUSTABLE, ROLL IN	2
12	SC-22281	SCREW, M5x0.8X16MM FLAT	2

5033753_1

External Fasteners, Gas

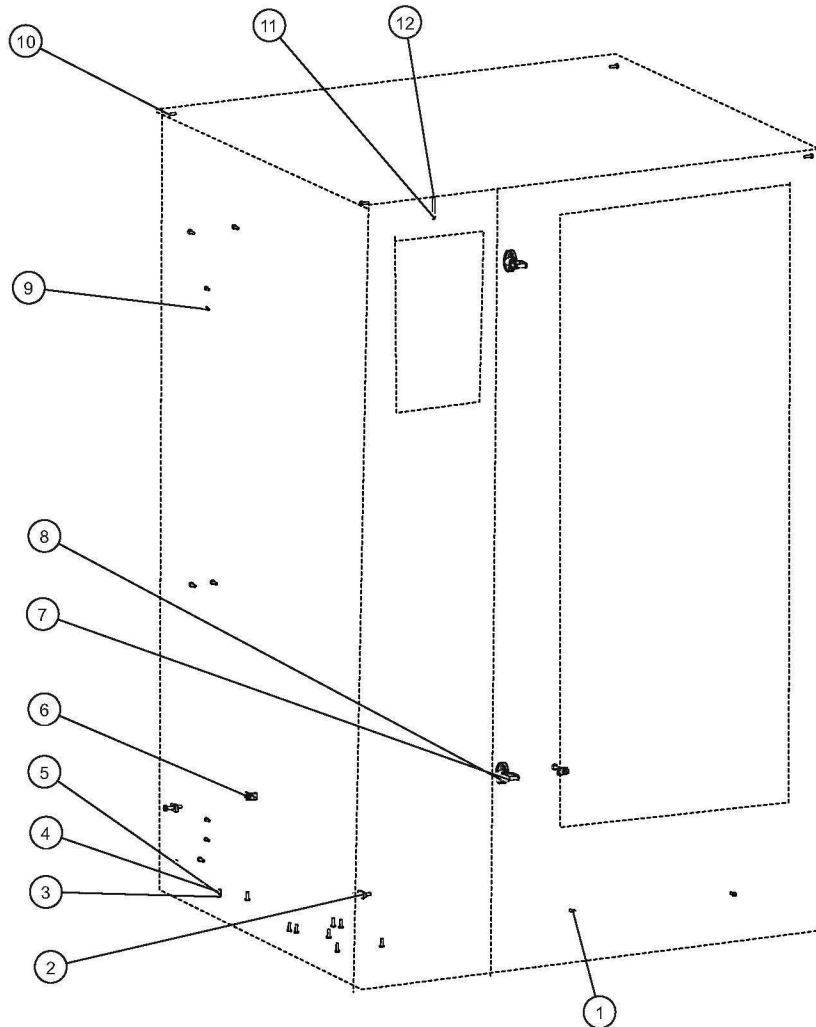

ID	Part No.	Description	Qty
1	SC-22281	SCREW, M5x0.8X16MM FLAT	2
2	NU-24004	NUT, U-STYLE 1/4-20 THREADED	4
3	NU-22291	M6-1.0 X HEX S/S NUT 18-8	2
4	WS-22297	WASHER, FLAT, M6, 18-8 SST	2
5	WS-22302	WASHER, M6 SPLIT LOCK	2
6	SC-39832	SCREW, 1/4-20X1 1/2", PAN	4
7	BP-38451	LATCH, ADJUSTABLE, ROLL IN	2
8	SC-38487	SCREW, M5x0.8X20MM PAN	4
9	SC-37702	SCREW, M4 X 12MM SEMS	4
10	SC-47718	SCREW, M5 X 16MM SEMS	18
11	NU-35233	ACORN CAP NUT, M5	1
12	SC-35259	SCREW, M5x0.8X50MM FLAT	1

5033957_1

Outer Casing Package, 20-10

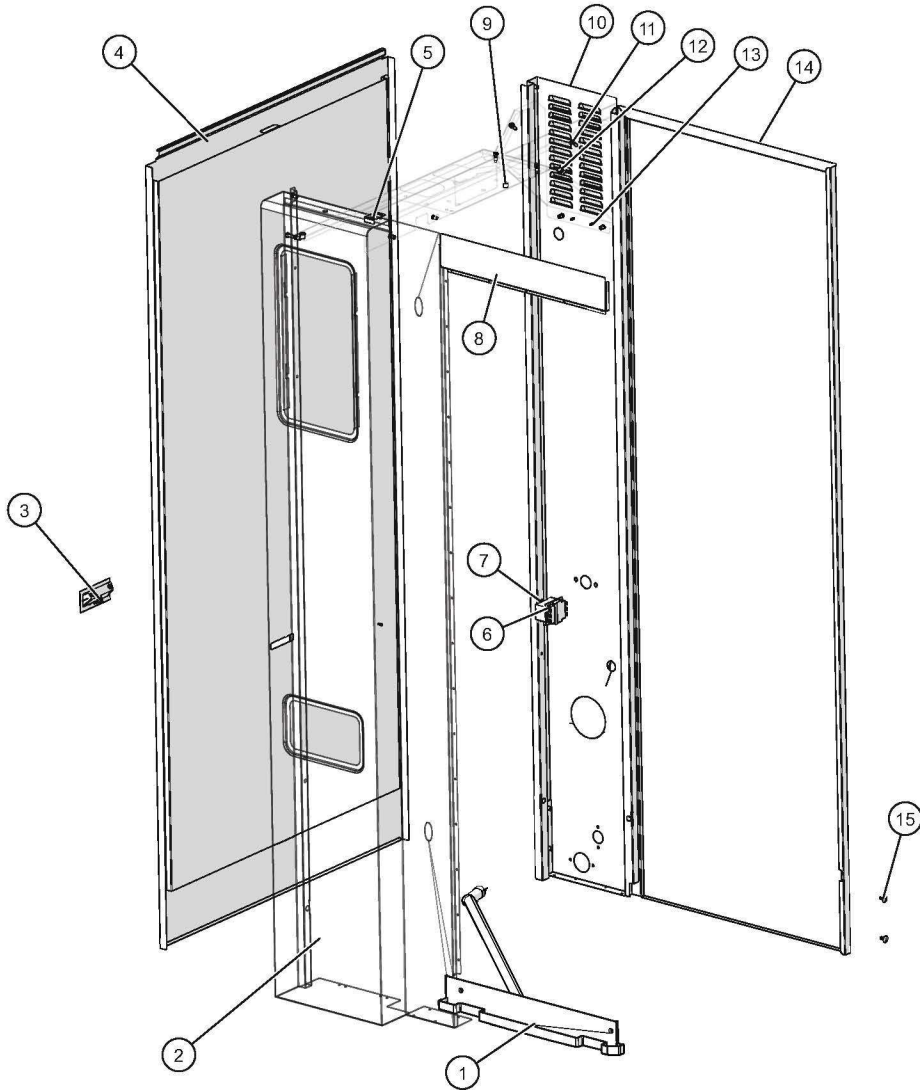

ID	Part No.	Description	Qty
1	DT-47732R	DRIP TRAY SVC KIT,PLASTIC	1
2	5033754	CONTROL HOUSING WELDMENT	1
3	HD-28789	HANDLE, PULL RECESSED, BLACK	1
4	5015264	PANEL,LH,ACCESS,ASSY,20-10	1
5	1039680	BRACKET,RETENTION,PANEL,LH	1
6	TT-36255	THERMOSTAT, THERMAL CUT-OUT	1
7	SC-22271	SCREW,M4x0.7X6MM PAN	2
8	1013321	PANEL, FRONT UPPER, CTC/CTP	1
9	BU-3419	3/8" BLACK HOLE BUSHING	2
10	5034539	PANEL,LH,SPOT	1
11	SC-47718	SCREW, M5 X 16MM SEMS	5
12	BU-3006	1/2" HOLE BUSHING	1
13	RI-38125	RIVET,SEALED,.125",GRIP .039-.118	4
14	1020534	PANEL, REAR ACCESS, 20-10	1
15	PG-47927	PLUG,XMAS TREE,.197" HOLE DIA	4

5035734_0

Core Package, RH, 20-10

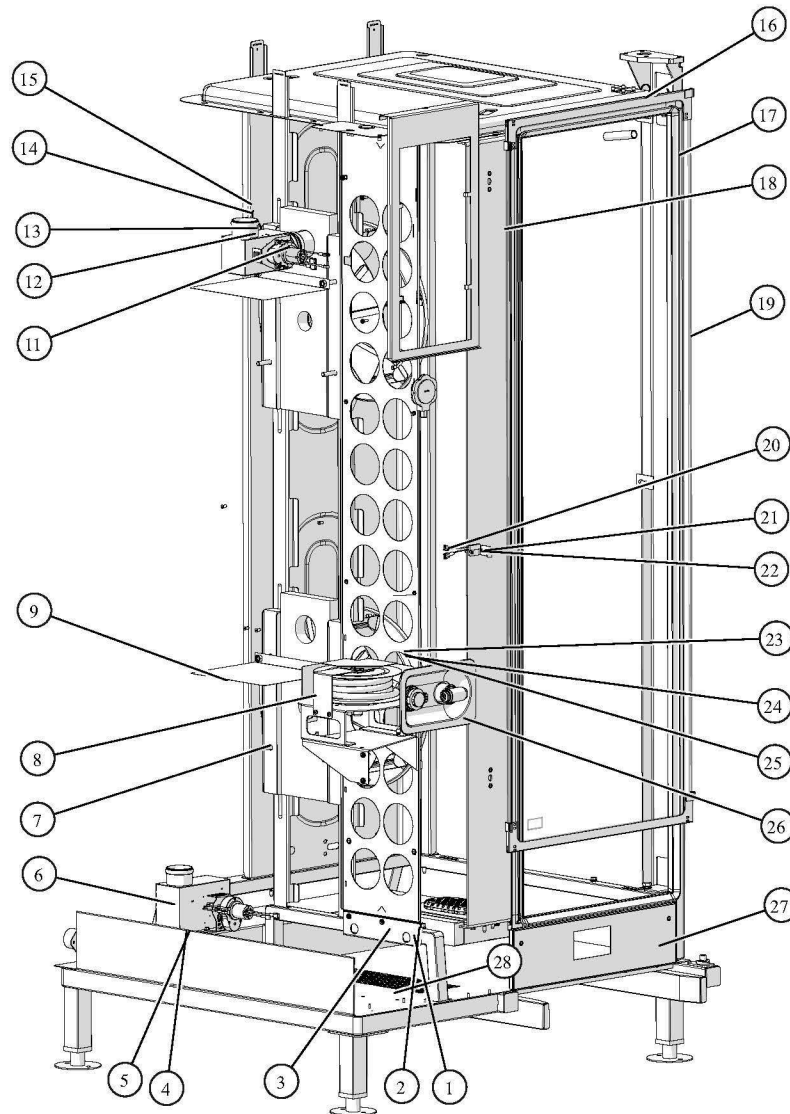

ID	Part No.	Description	Qty
1	SC-47718	SCREW, M5 X 16MM SEMS	10
2	WS-23725	5/16 FLAT WASHER	2
3	5035084	COVER,INSULATION,W-INSERTS	1
4	NU-39180	NUT,M4-0.7 HEX FLG-SERR CL8 SS	6
5	SA-37149	GASKET, 3MM, COND. TANK	1
6	VA-46327	VALVE, HUMIDITY VENT, LOWER	1
7	IN-36115	INSULATION, MOTOR CHANNEL	4
8	IN-36114	INSULATION, MOTOR PLATE, 7-20	2
9	CV-47297	COVER,MOTOR,CONVECTION,SHIELD	2
11	VA-46325	VALVE, HUMIDITY VENT, UPPER	1
12	NU-35846	NUT, KEPS, M3X0.5, SS	3
13	GS-39145	GASKET, THERMOCOUPLE SEAL	1
14	CR-33625	CONNECTOR, FERRULE #20	2
15	PR-46933	PROBE, 100 OHM, 110" WIRE,	1
16	PI-38491	PIN, QUICK RELEASE 5/16"	2
17	GS-38509	GASKET,DOOR	1
18	5033878	PLATE ASSY,BACKER,DOOR MTG	1
19	5034923	DOOR,INNER,GLASS,ASSY	1
20	5019145	REED SWITCH ASSY,W/CONNECTORS	1
21	1016109	BRACKET,DOOR SWITCH	1
22	NU-22285	NUT, M3-0.5 HEX NUT	1
23	1008395	CONICAL WASHER	1
24	NU-28710	NUT, M16 X 1.5 HEX JAM NUT,S.S.	1
25	EB-22221	ELBOW, 0.63 DIA, CENTER R.875	1
26	5033618	HANDSHOWER PACKAGE,W-USB	1
27	RI-27108	RIVET, SEALED	2
28	FE-2916	FOOT,INSERT,ADJUSTABLE,FLANGED	4
29	NU-22292	NUT, CT HEX, M8-1.25 18/8 (not shown)	8

5034909_3

Core Package, RH, 20-10 (rear view)

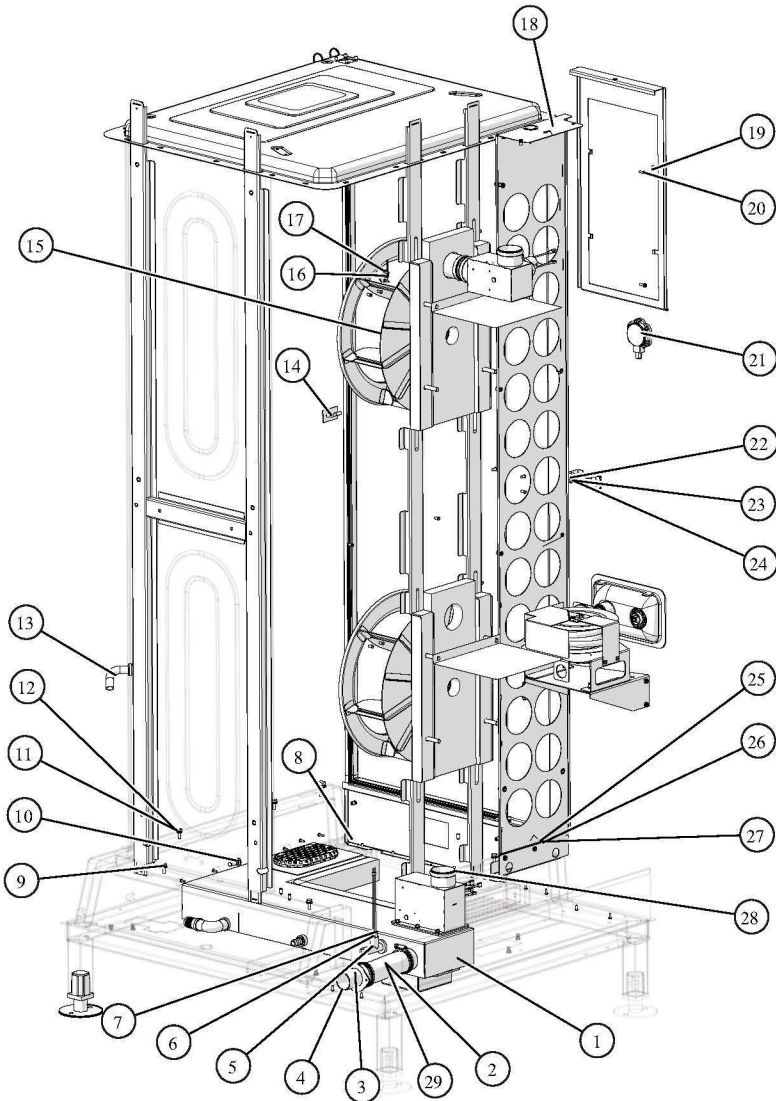

ID	Part No.	Description	Qty
1	5017848	WELDMNT, ASSY, COND. TANK	1
2	HO-35322	HOSE, 1.500" ID, 1.750" OD	1
3	CL-22234	CLAMP, WORM GEAR, 40-60, HOSE	2
4	5015257	WELDMNT, FLANGE, TUBE	1
5	FT-35159	FITTING, STEAM PROBE	1
6	WS-47896	WASHER, BONDED SEALING, 1/4"	2
7	SN-48422	SENSOR, 10K THERMISTOR, 100"	1
8	WS-22303	WASHER, M8 SPLIT LOCK	1
9	WS-22302	WASHER, M6 SPLIT LOCK	7
10	SC-22753	SCREW, M6 SS RND SHLDR	2
11	SC-22284	SCREW, M6x1.0x16MM HEX	6
12	WS-22297	WASHER, FLAT M6, 18-8 SST	6
13	EB-22221	ELBOW, 0.63 DIA, CENTER R.875	1
14	HL-23906	HOLDER S/S	1
15	WH-35847	WHEEL, 340MM DIA X 130 DEPTH	2
16	GS-39145	GASKET, THERMOCOUPLE SEAL	1
17	PR-46933	PROBE, 100 OHM, 110" WIRE,	1
18	1038095	PANEL, INSULATION COVER	1
19	5033485	PANEL, LOCKING, CONTROL, ASSY	1
20	SC-37702	SCREW, M4 X 12MM SEMS	2
21	BZ-48098	BUZZER, TRANSDUCER, 5W	1
22	WS-22299	WASHER, M3 SPLIT LOCK	1
23	SC-22270	SCREW, M3x0.5X16MM PAN	1
24	WS-22293	WASHER, FLAT M3, 18-8 SST	2
25	SC-2191	SCREW, HEX HEAD, 5/16-18 X 1" LONG	2
26	WS-23725	5/16 FLAT WASHER	2
27	WS-2867	WASHER, LOCK, 5/16 DIA.	2
28	RI-38125	RIVET, SEALED, .125"	16
29	NU-25059	NUT, *CT, ML, S/S	1

5034909DV1_3

Side Panel Assembly, RH Door

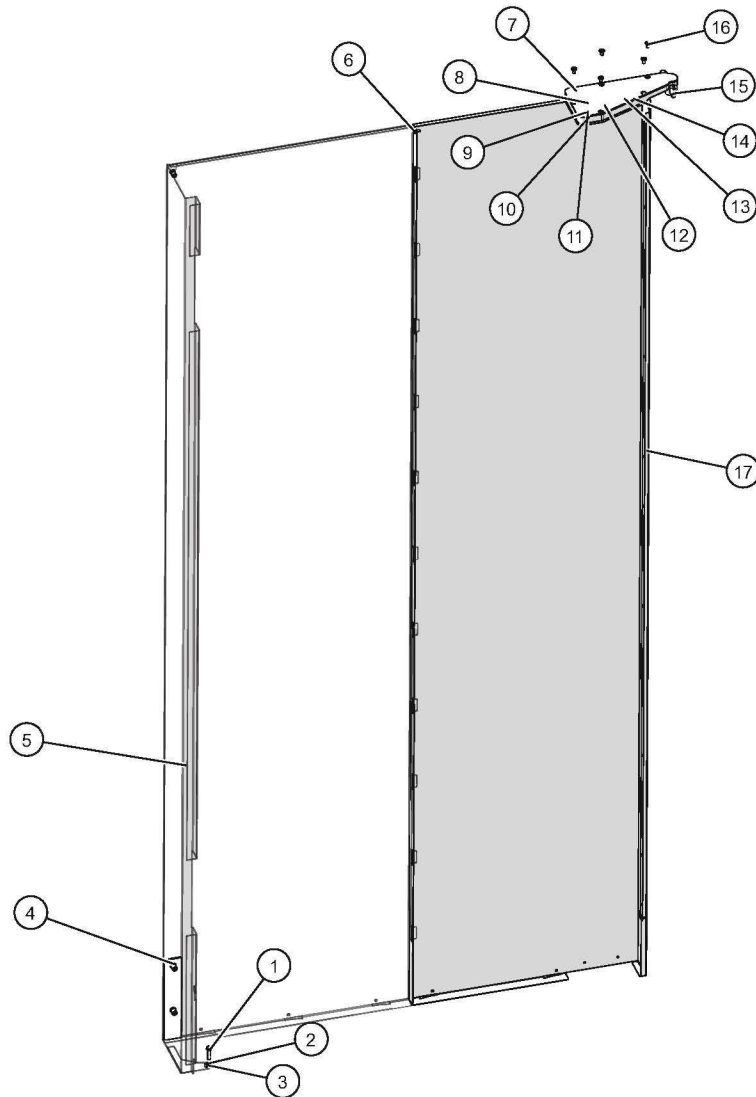

ID	Part No.	Description	Qty
1	SC-22779	SCREW,M5x0.8X20MM PAN	1
2	WS-22301	WASHER, M5 SPLIT LOCK	1
3	WS-22296	WASHER, M5 X 15MM , 18-8SS	1
4	SC-22753	SCREW, M6 SS RND SHLDR	2
5	5022104	SPOT ASM, SIDE PANEL, RH DOOR	1
6	RI-38125	RIVET,SEALED,.125", GRIP .039-.118	1
7	1019918	TOP HINGE COVER	1
8	RI-27108	RIVET, SEALED, 0.125"x0.45"	2
9	WS-22298	WASHER, M8, 18-8	4
10	SC-38476	SCREW, M8X1.25X20MM, HEX	4
11	WS-22303	WASHER, M8 SPLIT LOCK	4
12	1021942	SHIM, TOP HINGE 20.20/20.10	1
13	HG-38407	HINGE, TOP, COMBI DOOR,	1
14	NU-23909	NUT, HEX INSERT M5	1
15	HG-35503	HINGE, UPPER DOOR STOP	1
16	SC-36226	SCREW,M4x0.7X8MM FLAT	5
17	1037579	PANEL, RIGHT SIDE RH DOOR	1

5035731_0

Top Panel Weldment

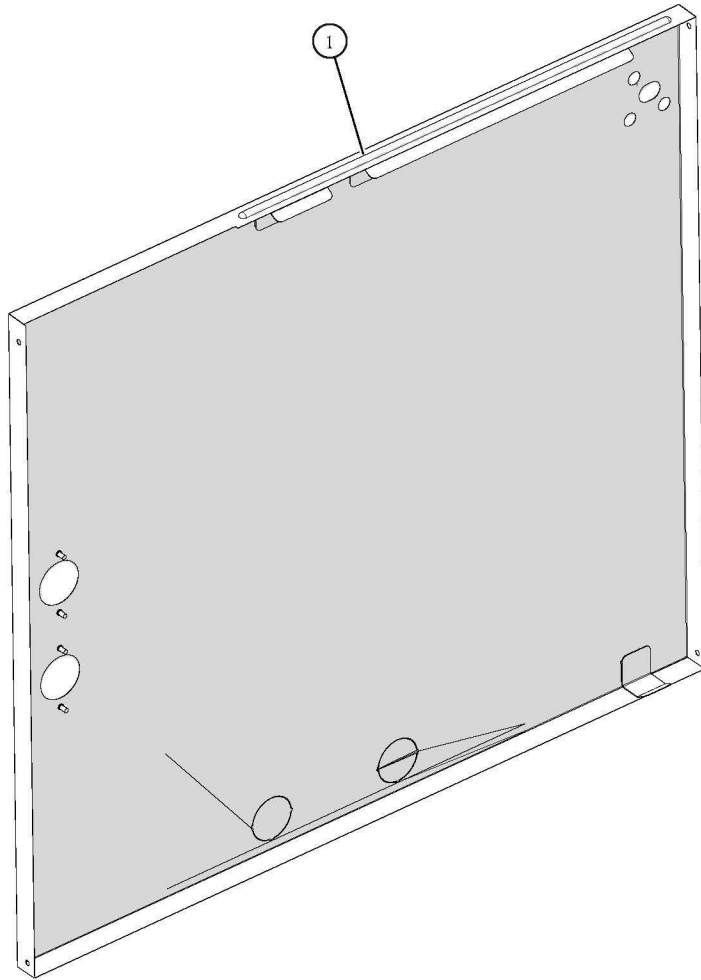

ID	Part No.	Description	Qty
1	5022105	PANEL, TOP, WELDMENT, 20-10	1

5022105_7

Cover Assembly, 20-10

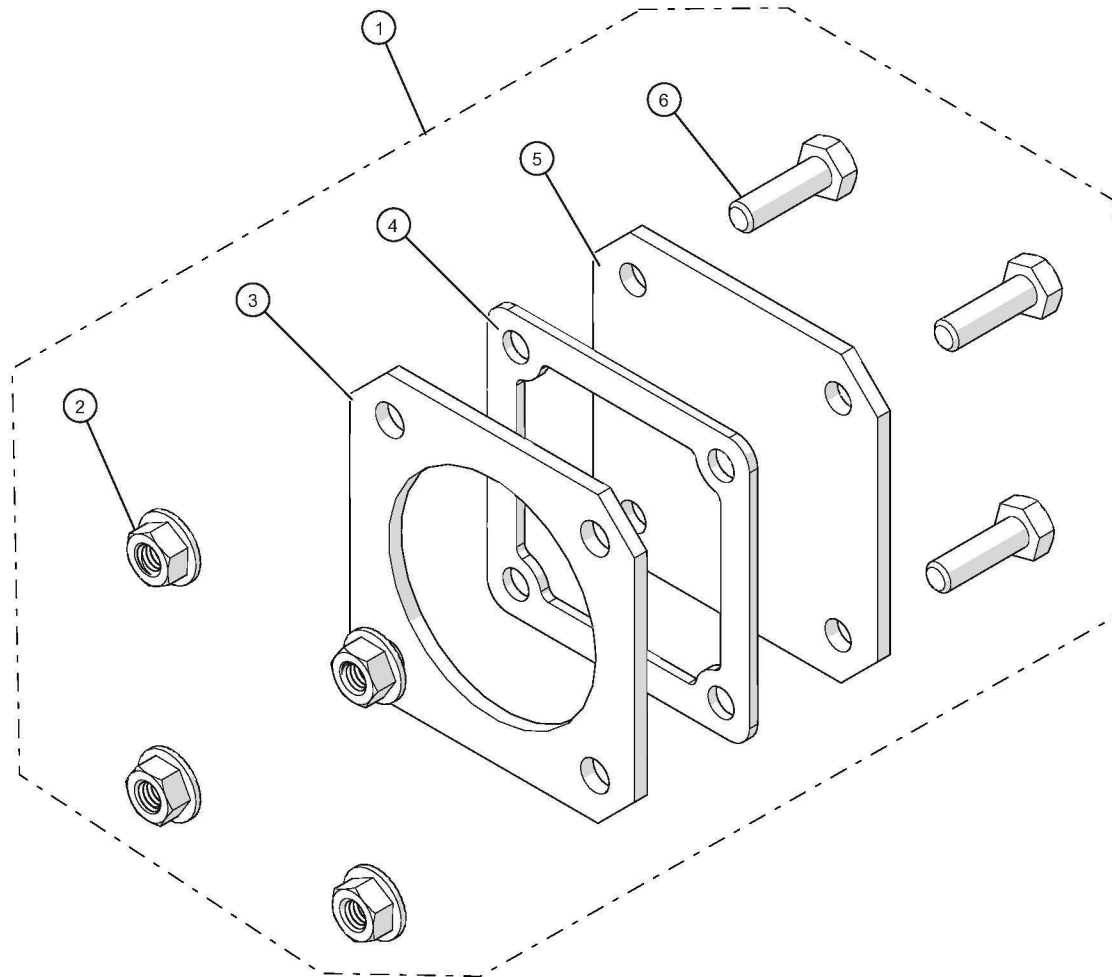

ID	Part No.	Description
1	5015331R	COVER ASSY, SERVICE
2	NU-38844	NUT, M6 X 1, SERRATED FLANGE
3	1023061	PLATE, STIFFENER REAR COVER
4	GS-38840	GASKET, EXHAUST TUBE, 50MM
5	1022941	PLATE, REAR COVER, M6
6	SC-38922	SCREW, M6 X 1 X 20MM, HEX HEAD

5015331_7

Door Service Kit, 20-10

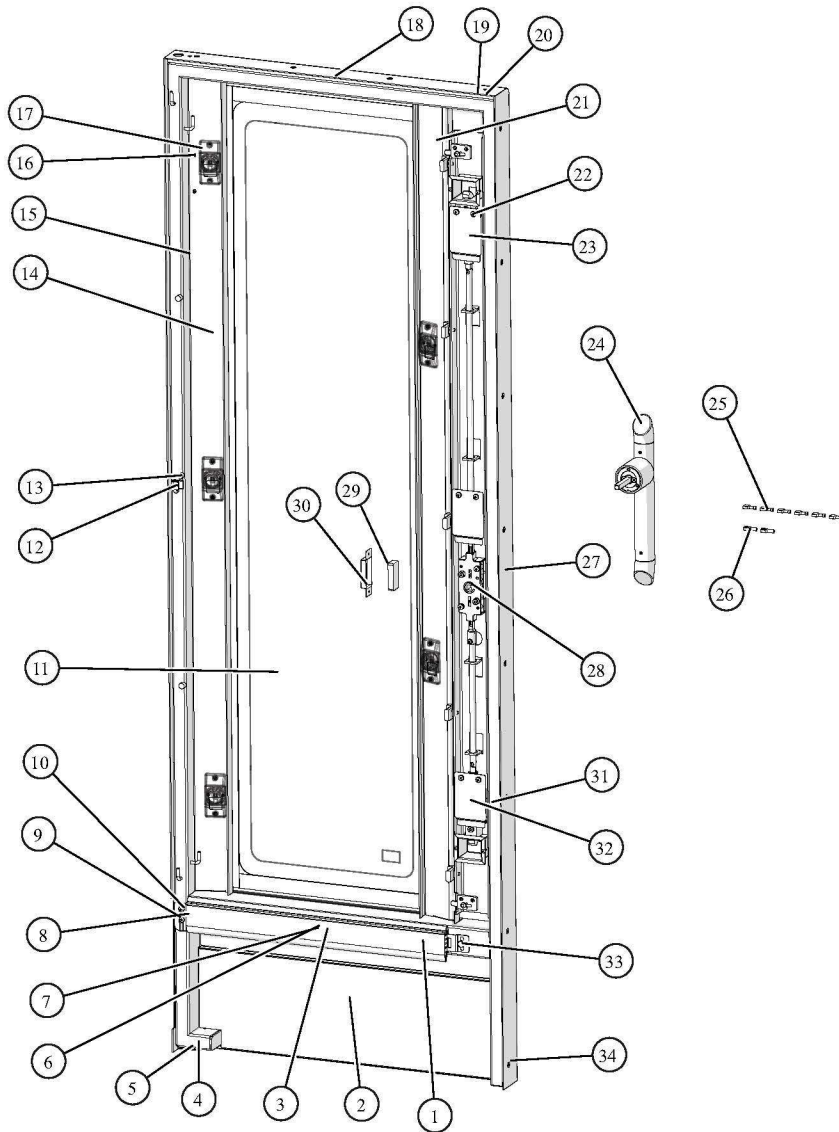

ID	Part No.	Description	Qty
1	SC-36350	SCREW, M5X.8X10MM BTN FLG	3
2	1039575	PLATE, TROLLEY GUARD, DOOR	1
3	1022971	STRAP, 20.10, SWEEP RETENTION	1
4	SC-27274	M6 X 25mm PHIL. FLAT HEAD SCREW	1
5	HG-38430	HINGE, UPPER RATCHET, W RADIUS	1
6	1020730	SPACER, SWEEP GASKET	1
7	1014913	HOLDER, SWEEP GASKET, GEN-2	1
8	GS-38511	GASKET, 20.10 SWEEP GASKET	1
9	BK-39768	BLOCK, SWEEP GASKET	1
10	SC-22779	SCREW, M5x0.8X20MM PAN	2
11	GL-47531	GLASS, 6MM, OUTER PANE	1
12	HG-48515	HINGE GUIDE, CENTER HOLD	1
13	1020155	BUMPER, GLASS, ROLL IN	3
14	1036485	PANEL, LED, HINGE SIDE	1
15	RI-27108	RIVET, SEALED	14
16	SC-22266	SCREW, M3x0.5X6MM PAN	10
17	5028680	LIGHT, CABINET LED	5
18	1020340	SPACER, DOOR FRAME	1
19	BU-36038	3/8" BUSHING, SPLIT	3
20	SC-22281	SCREW, M5x0.8X16MM FLAT	24
21	1036541	PANEL, LED, HANDLE SIDE	1
22	SC-22766	SCREW, M5x0.8X10MM PAN	7
23	5033100	LATCH, DOOR, ASSY	1
24	HD-47706	HANDLE, DOOR, ROLL-IN COMB	1
25	CR-37261	CONNECTOR, 24-26 AWG FEMALE, .250" TAB	6
26	CR-33509	CONNECTOR, 18-22 AWG FEMALE, .250" TAB	2
27	RI-38125	RIVET, SEALED, .125"	6
28	SC-36662	SCREW, M4X.7 X 12MM SCH HEX SCH	3
29	MA-27568	MAGNET, NDFEB	1
30	1007699	COVER, MAGNET, INSIDE, SINGLE	1
31	SC-48525	SCREW, M6X1X16, EXT, HX SERR-FLG	3
32	1036480	COVER, ACCESS, LATCH, ASSY	3
33	SC-38934	SCREW, KNURLED HEAD THUMB, M5,	1
34	1039574	DOOR, OUTER, RH	1
35	TA-37218	TAPE, 1.00" X 0.62" THK, 139"L (not shown)	1

5035725_2

Middle Glass Door Assembly, 20-10

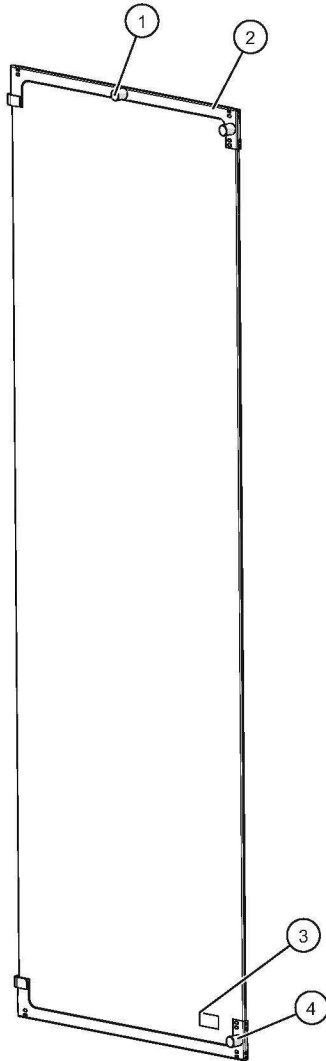

ID	Part No.	Description	Qty
1	BM-38762	BUMPER STOP/MIDDLE GLASS	3
2	5022440	MIDDLE TOP EDGE 20-10	1
3	GL-47532	GLASS, 6MM, MIDDLE PANE,	1
4	5022441	MIDDLE BOTTOM EDGE 20-10	1

5034924_4

Drip Tray Service Kits (all models)

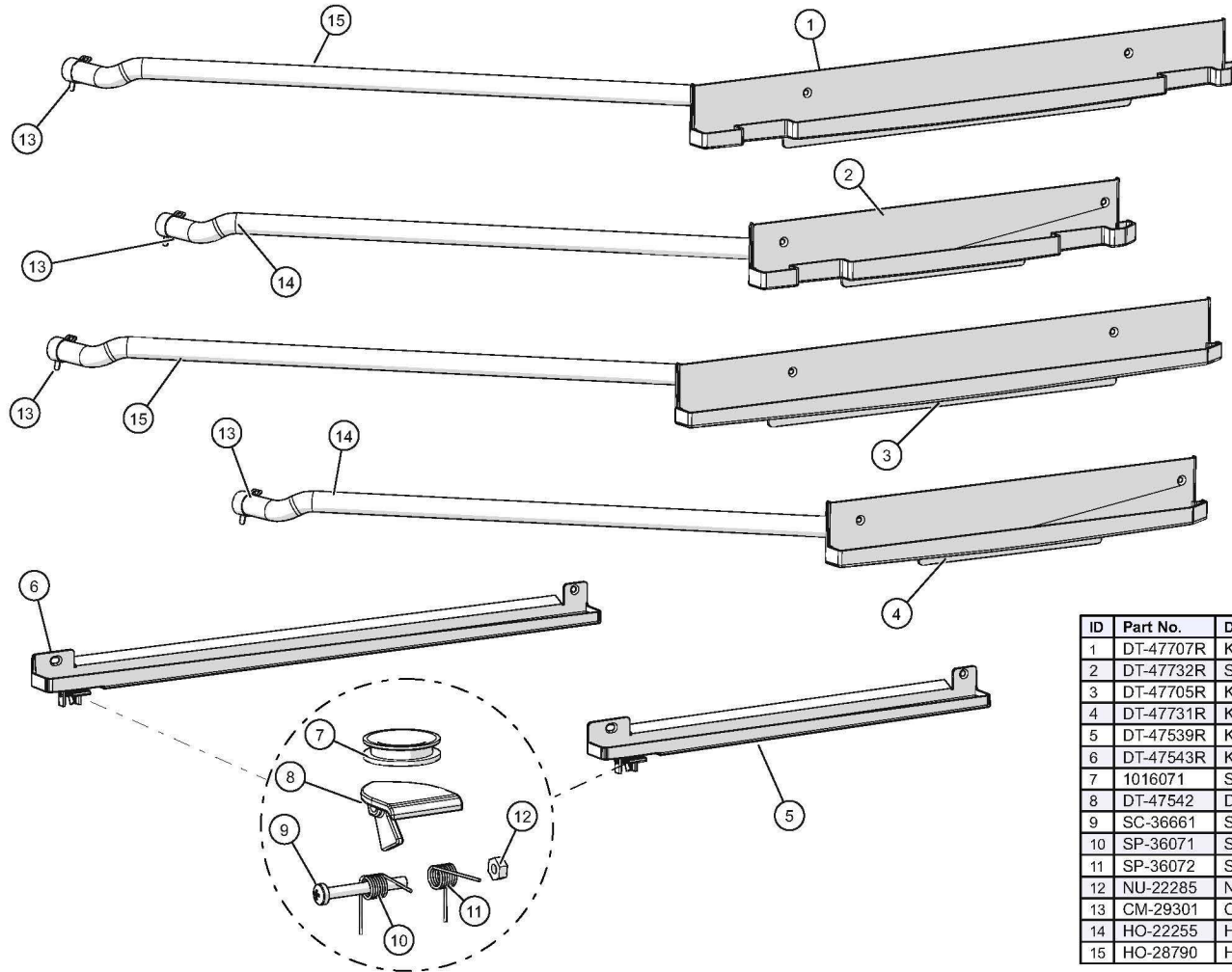

ID	Part No.	Description
1	DT-47707R	KIT,SERVICE,DRIP TRAY,20-20
2	DT-47732R	SERVICE KIT,DRIP TRAY, 20-10
3	DT-47705R	KIT,SERVICE,DRIP TRAY,7-20 & 10-20
4	DT-47731R	KIT,SERVICE,DRIP TRAY,6-10 & 10-10
5	DT-47539R	KIT,SERVICE,DOOR DRIP TRAY,6-10 & 10-10
6	DT-47543R	KIT,SERVICE,DOOR DRIP TRAY,7-20 & 10-20
7	1016071	SEAL, O-RING, DRIP TRAY
8	DT-47542	DRIP TRAY,PLUNGER TAB
9	SC-36661	SCREW,M3x0.5X25MM PAN
10	SP-36071	SPRING, TORSION, 180°,RH
11	SP-36072	SPRING, TORSION, 180°,LH
12	NU-22285	NUT, M3-0.5 HEX NUT
13	CM-29301	CLAMP, HOSE, 23MM
14	HO-22255	HOSE, 0.5" ID X 27 7/16" LG
15	HO-28790	HOSE, 0.5" ID X 32 7/16" LG

Directional Panel Assemblies (all models)

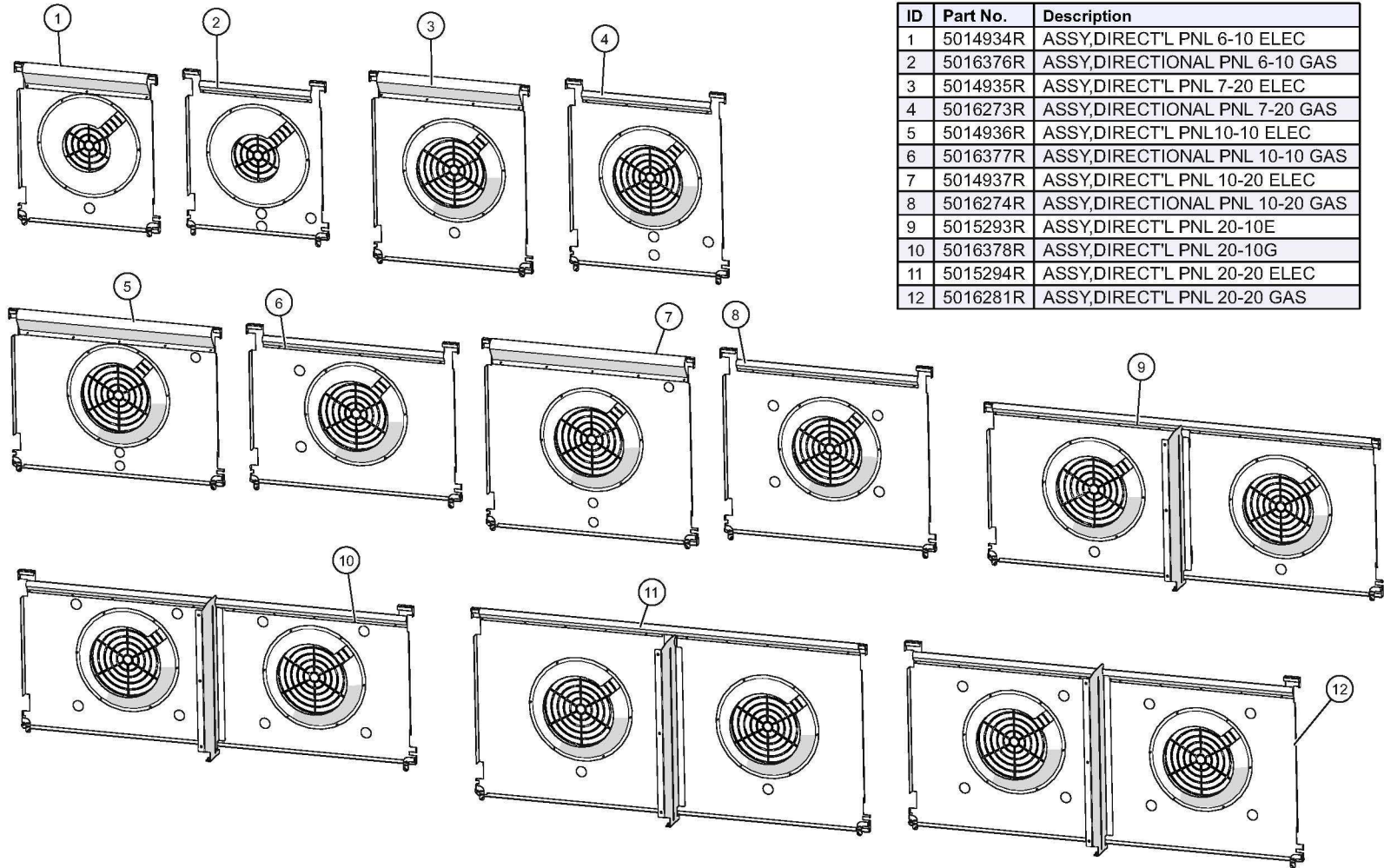

ID	Part No.	Description
1	5014934R	ASSY,DIRECT'L PNL 6-10 ELEC
2	5016376R	ASSY,DIRECTIONAL PNL 6-10 GAS
3	5014935R	ASSY,DIRECT'L PNL 7-20 ELEC
4	5016273R	ASSY,DIRECTIONAL PNL 7-20 GAS
5	5014936R	ASSY,DIRECT'L PNL10-10 ELEC
6	5016377R	ASSY,DIRECTIONAL PNL 10-10 GAS
7	5014937R	ASSY,DIRECT'L PNL 10-20 ELEC
8	5016274R	ASSY,DIRECTIONAL PNL 10-20 GAS
9	5015293R	ASSY,DIRECT'L PNL 20-10E
10	5016378R	ASSY,DIRECT'L PNL 20-10G
11	5015294R	ASSY,DIRECT'L PNL 20-20 ELEC
12	5016281R	ASSY,DIRECT'L PNL 20-20 GAS

Gas Package, 20-10, 120V 30KW

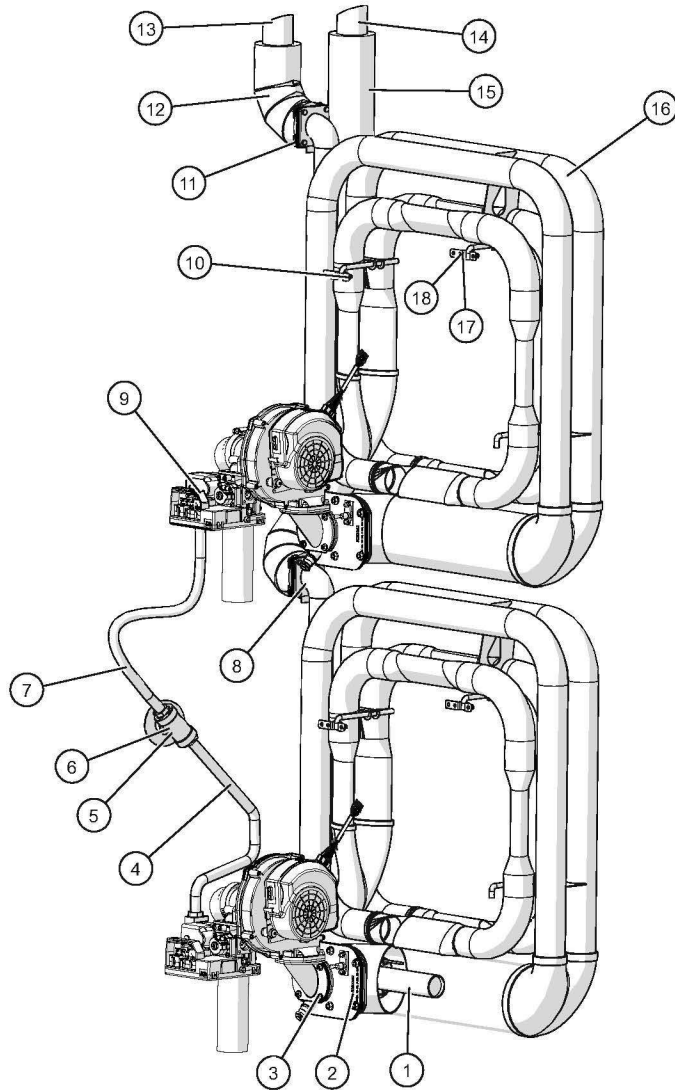

ID	Part No.	Description	Qty
1	BN-29609	BURNER, PREMIX 36MM DIA, 20KW	2
2	IG-37317	IGNITER. HOT SURFACE, 120V	2
3	CR-34639	CONNECTOR, QUICK DISCONNECT	4
4	HO-35895	HOSE, GAS 1/2" ID 460mm, BOTTOM	1
5	FT-35892	FITTING, TEE 3/4" NPT	1
6	5016250	WELD, GAS PIPE MOUNT	1
7	HO-35895	HOSE, GAS 1/2" ID 460mm, TOP	1
8	1022700	29MM FLUE RESTRICTOR	2
9	SC-29276	SCREW, M4x0.7X30MM PAN	2
10	WS-22301	WASHER, M5 SPLIT LOCK, SS	8
11	NU-38844	NUT, M6 X 1, SERRATED FLANGE	10
12	1023659	INSUL, 0.5" E-GLASS, 2" TUBE	2
13	5023363	TUBE ASSY, GAS EXHAUST, 7-20	1
14	5023364	TUBE ASSY, GAS EXHAUST, 20	1
15	1023440	INSUL, 0.5" E-GLASS, 2" TUBE	1
16	5023360	HEAT EXCHANGER, 30KW HORIZONTAL	2
17	NU-35233	ACORN CAP NUT, M5, 18-8 S/S	8
18	1013269	BRACKET, HEAT EXCHANGER WIRE	4

5034764_0

Gas Package, 20-10, 120V 30KW (detail view)

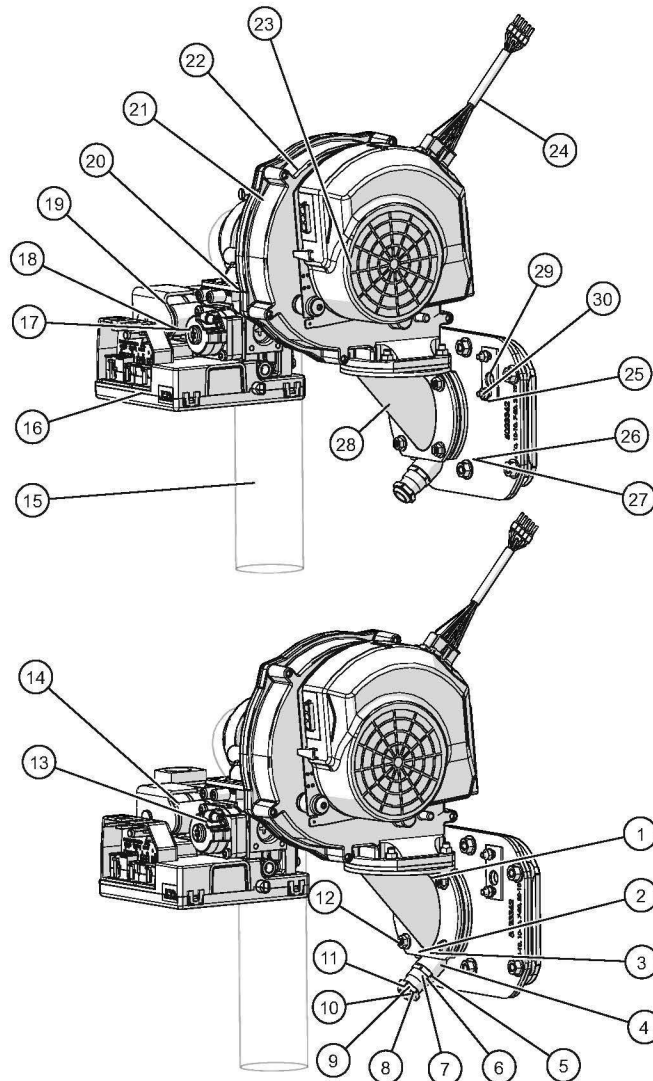

ID	Part No.	Description	Qty
1	GS-37343	GASKET, RESTRICTOR PLATE	6
2	NU-38844	NUT, M6 X 1, SERRATED FLANGE	14
3	SC-38922	SCREW, M6 X 1 X 20MM, HEX HEAD	14
4	BU-36318	BUSHING, CONNECTOR FOR BURNER	2
5	SA-22199	SEAL, CT, O-RING, VITON, 13X1.5	2
6	PG-3826	PLUGS,*CT,ADAPTER,TUBE TO PLUG	2
7	WS-22323	WASHER, FLAT 4.5MM I.D. X 13.5MM O.D.	2
8	SA-22321	SEAL, CT, CONE, PG9, BRASS	2
9	SA-22322	SEAL, CT, INSERT, 4mm DIA	2
10	WS-22297	WASHER, FLAT, M6, 18-8 SST	2
11	SA-22320	SEAL, CT, TOP, PG9	2
12	NU-38212	NUT,M5-0.8 HEX FLG-SERR CL8 SS	16
13	VA-39851	VALVE, GAS 155 V	2
14	VA-27081	ELBOW, FLANGE, VENTURI,	2
15	HO-36604	HOSE, 2" ID, 11.642" LG	2
16	BA-39849	BOARD, IGNITION CONTROL, 120 V	2
17	OR-27249	SEAL, O-RING 1.068 OD X 0.103 DIA	1
18	SC-29276	SCREW,M4x0.7X30MM PAN	2
19	SC-22273	SCREW,M4x0.7X10MM PAN	2
20	SA-27930	SEAL, GAS VALVE	1
21	CM-38394	CLAMP, WORM GEAR, LINED	2
22	FA-34232	FAN, RADIAL BLOWER ELEK INTL-	2
23	SC-22766	SCREW,M5x0.8X10MM PAN	3
24	5016122	CABLE,PWM WITH 5 PIN CONNECTOR	2
25	5023617	BURNER SUBASSY, FULL PREMIX	2
26	GS-38881	GASKET, HEAT EXCHANGER,CHAMBER	2
27	GS-38858	GASKET, BURNER FLANGE	2
28	5017865	STRAIGHT ELBOW, GAS BLOWER	2
29	GS-29627	GASKET, IGNITION COMPONENT	2
30	NU-36319	NUT, M4, KEPS, ZINC PLATED	4

5034764DV1_0

Gas Conversion Kits

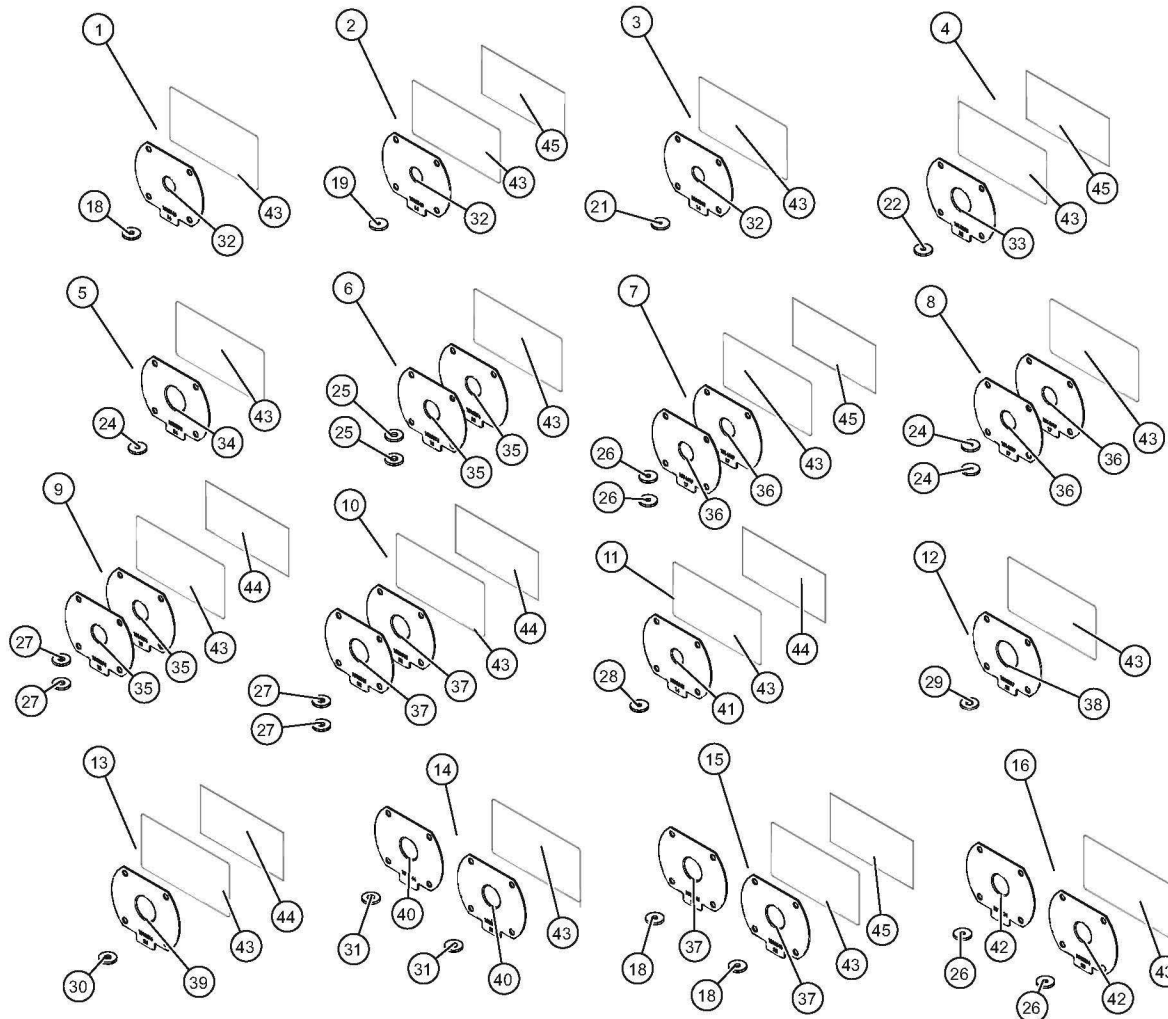

ID	Part No.	Description
1	5025066	CONV KIT, 6-10, GAS TO G25, LOW CAL NG
2	5025067	CONV KIT, 6-10, GAS TO G31, PROPANE
3	5025068	CONV KIT, 6-10, GAS TO G30, BUTANE
4	5025069	CONV KIT, 7-20, GAS TO G31, PROPANE
5	5025070	CONV KIT, 7-20, GAS TO G30, BUTANE
6	5025071	CONV KIT, 10-10 & 20-10, GAS TO G25, LOW CAL NG
7	5025072	CONV KIT, 10-10 & 20-10, GAS TO G31, PROPANE
8	5025073	CONV KIT, 10-10 & 20-10, GAS TO G30, BUTANE
9	5025074	CONV KIT, 10-10 & 20-10, GAS TO G20, NG
10	5025075	CONV KIT, 10-20 & 20-20, GAS TO G20, LOW CAL NG
11	5025370	CONV KIT, 6-10, GAS TO G20, NG
12	5025371	CONV KIT, 7-20, GAS TO G25, LOW CAL NG
13	5025372	CONV KIT, 20-10, GAS TO G20, NG
14	5025375	CONV KIT, 10-20 & 20-20, GAS TO G25, LOW CAL NG
15	5025376	CONV KIT, 10-20 & 20-20, GAS TO G31, PROPANE
16	5025377	CONV KIT, 10-20 & 20-20, GAS TO G30, BUTANE
17	SRV-20058	SERVICE DOC. CONVERTING GAS (provided with all kits)
18	OR-35874	ORIFICE, GAS VALVE DISC 4.60mm
19	OR-36626	ORIFICE, GAS VALVE DISC 2.75mm
21	OR-35878	ORIFICE, GAS VALVE DISC 2.80mm
22	OR-36628	ORIFICE, GAS VALVE DISC 4.20mm
24	OR-35877	ORIFICE, GAS VALVE DISC 4.00mm
25	OR-36007	ORIFICE, GAS VALVE DISC 6.00mm
26	OR-35878	ORIFICE, GAS VALVE DISC 4.10mm
27	OR-35943	ORIFICE, GAS VALVE DISC 5.70mm
28	OR-36625	ORIFICE, GAS VALVE DISC 3.75mm
29	OR-36006	ORIFICE, GAS VALVE DISC 6.30mm
30	OR-36627	ORIFICE, GAS VALVE DISC 5.55mm
31	OR-36207	ORIFICE, GAS VALVE DISC 6.40mm
32	1013843	PLATE, RESTRICTOR COMBI, 14MM
33	1015075	PLATE, RESTRICTOR COMBI, 23MM
34	1015076	PLATE, RESTRICTOR COMBI, 24MM
35	1015074	PLATE, RESTRICTOR COMBI, 18MM
36	1014619	PLATE, RESTRICTOR COMBI, 17MM
37	1013845	PLATE, RESTRICTOR COMBI, 22MM
38	1012817	PLATE, RESTRICTOR COMBI, 25MM
39	1015076	PLATE, RESTRICTOR COMBI, 24MM
40	1013844	PLATE, RESTRICTOR COMBI, 21MM
41	1013843	PLATE, RESTRICTOR COMBI, 14MM
42	1012504	PLATE, RESTRICTOR COMBI, 20MM
43	LA-26349	LABEL LAMINATE, OVER SERIAL PLT
44	LA-39481	LABEL, CONVERT TO NATURAL GAS
45	LA-39482	LABEL, CONVERT TO PROPANE GAS

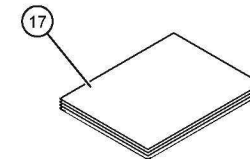

Gas Valve Orifices

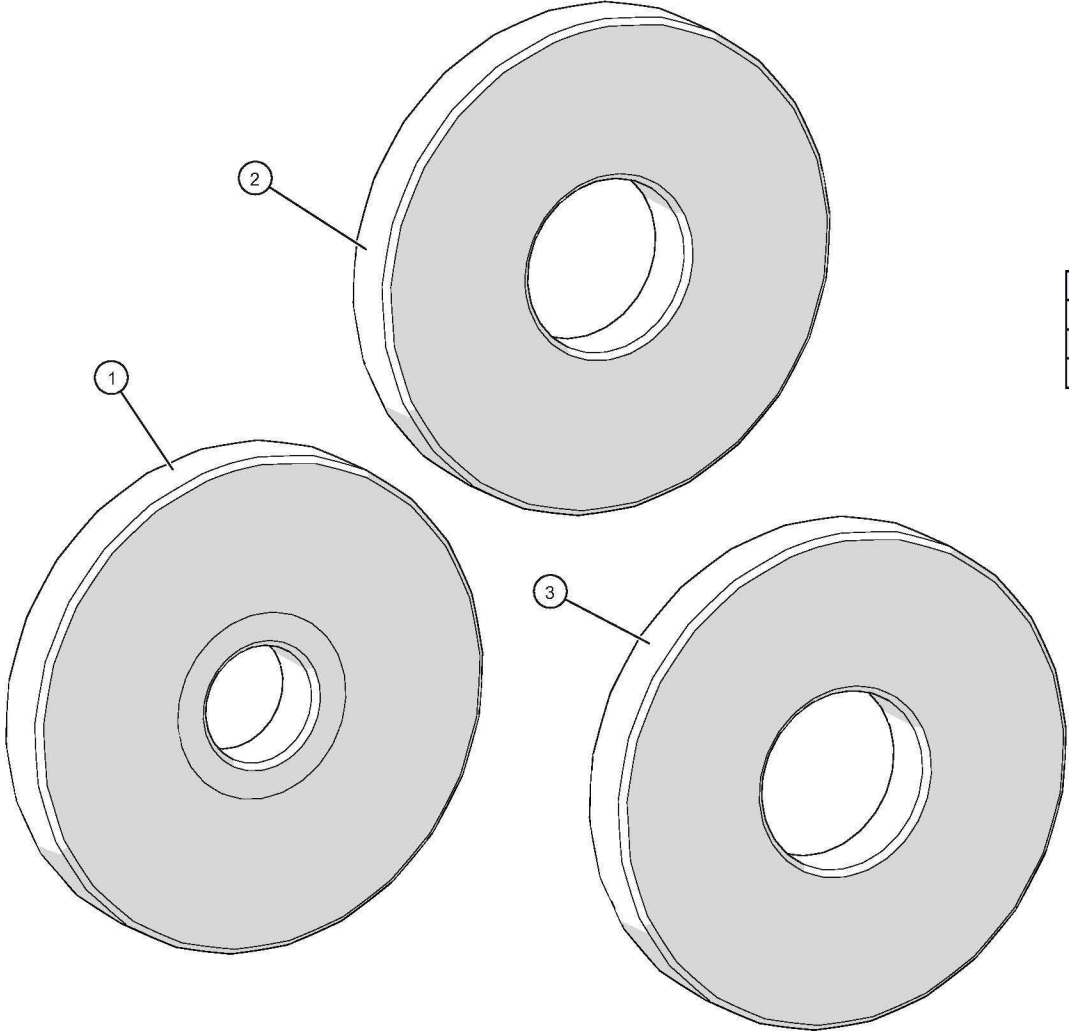

ID	Part No.	Description
3	OR-35943	ORIFICE, GAS VALVE DISC 5.70mm
1	OR-36625	ORIFICE, GAS VALVE DISC 3.75mm
2	OR-36627	ORIFICE, GAS VALVE DISC 5.55mm

Plumbing and Hoses, 20-10

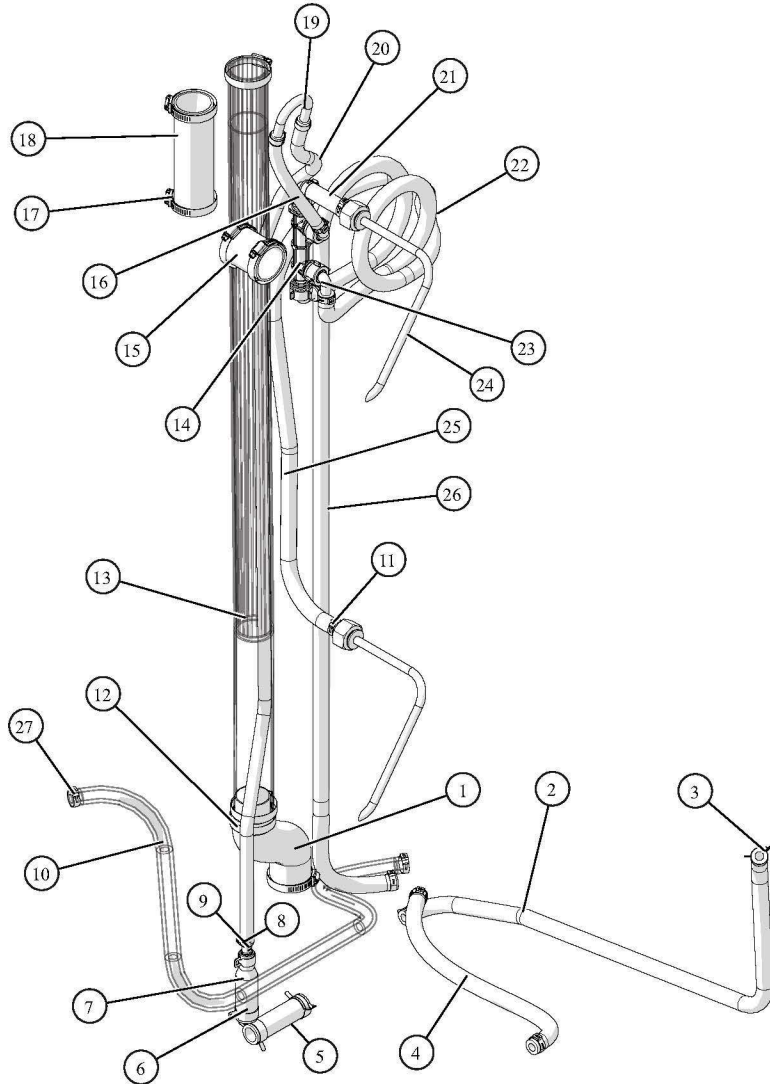

ID	Part No.	Description	Qty
1	HO-35091	HOSE, OFFSET, 2" OD TUBE	1
2	HO-28790	HOSE, 0.5" ID, B5	1
3	CM-29301	CLAMP, HOSE, 23MM	3
4	HO-28790	HOSE, 0.5"ID, Y2	1
5	HO-27892	HOSE, 0.875" ID, PUMP/COND	1
6	CM-29037	CLAMP, HOSE, 32MM	3
7	PB-29289	REDUCER, 7/8"X1/2"	1
8	CM-47212	EAR CLAMP,9MM BAND,17.8 - 21mm ID	4
9	PB-29489	COUPLER, 1/2" TO 1/2",	1
10	HO-22255	HOSE, 0.5" ID, SHOWER	1
11	CM-46927	EAR CLAMP,9MM BAND,20.9 - 24.1 mm ID	10
12	TU-36666	TUBE, COUPLING	1
13	HO-35321	HOSE, 2" ID, COND EXH	1
14	5017171	ASSEMBLY, WATER MANIFOLD	1
15	HO-37289	HOSE, 50mm ID, CAVITY TO VENT	1
16	HO-22255	HOSE, 0.5" ID, Y4_02	1
17	CM-38394	CLAMP, WORM GEAR, LINED	8
18	HO-35321	HOSE, 50MM ID, VALVE TO VENT	1
19	FT-36445	FITTING, SST, U-SHAPE	1
20	HO-22255	HOSE, 0.5" ID, Y4	1
21	HO-28790	HOSE, 0.5" ID,INJECTION	1
22	HO-28790	HOSE, 0.5"ID, Y1, LOOP	1
23	HO-22116	FITTING, ELBOW, 90 DEG.,	1
24	5015647	INJECTION TUBE ASSY	2
25	HO-28790	HOSE, 0.5" ID, Y1B, INJ, LOWER	1
26	HO-28790	HOSE, 0.5" ID, Y3	1
27	CM-47212	EAR CLAMP,9MM BAND,20.9 - 24.1 mm ID	2

5036425_0

Grease Collection Package (no grease collection)

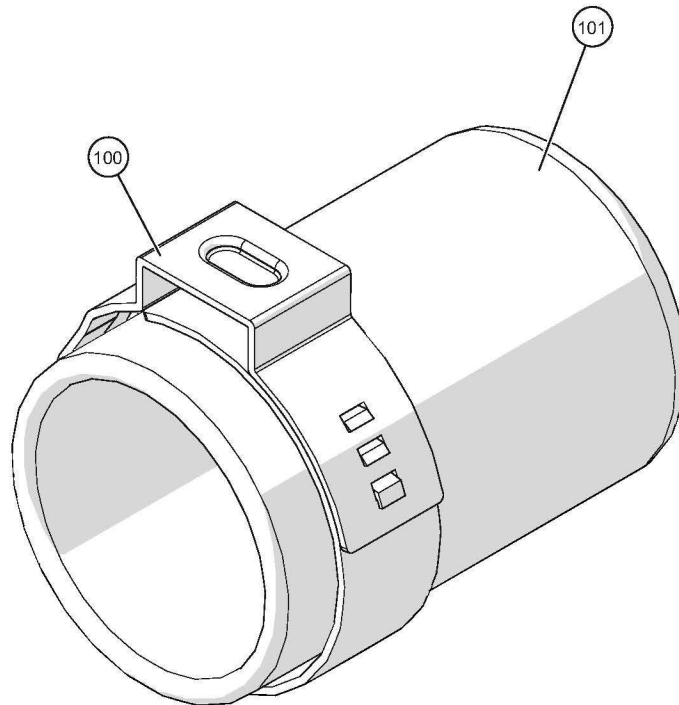

ID	Part No.	Description
100	CM-47399	CLAMP, RESISTANT PINCH
101	CP-47400	CAP, VINYL, FLEXIBLE, .875 ID

5016316_15

Grease Collection Package, 120V

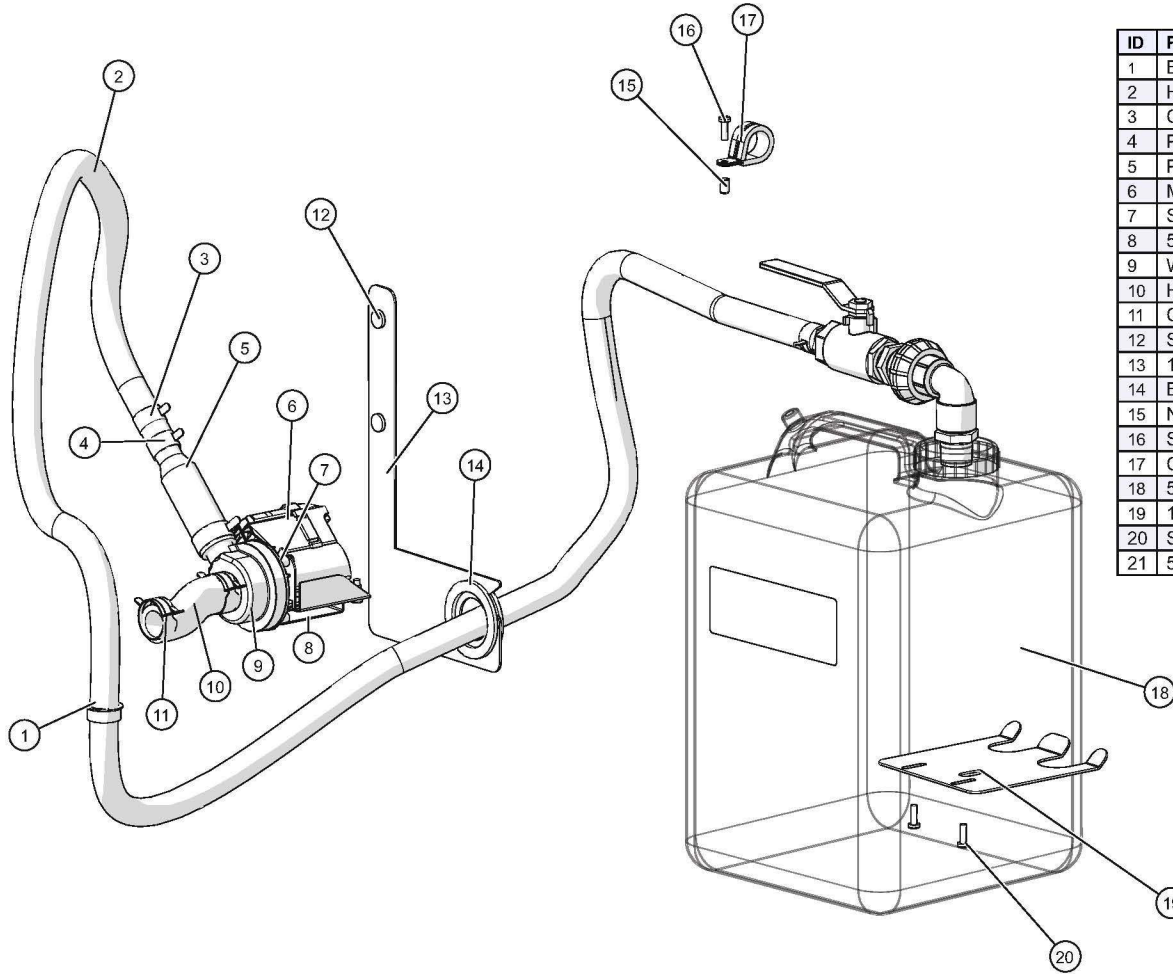

ID	Part No.	Description	Qty
1	BU-3378	1 1/8" SNAP BUSHING	1
2	HO-28790	HOSE, 0.5" ID, GC, 80"	1
3	CM-29301	CLAMP, HOSE, 23MM	2
4	PB-29489	COUPLER, 1/2" TO 1/2"	1
5	PB-29289	REDUCER, 7/8"X1/2"	1
6	MO-35262	PUMP, WASH SYSTEM, 110V	1
7	SC-22307	SCREW M4.8 X 16mm PHIL PAN HEAD	2
8	5015109	BRACKET ASSY, MOTOR MOUNTING	1
9	WS-22301	WASHER, M5 SPLIT LOCK S/S 18-8	2
10	HO-27892	HOSE, 0.875" ID, GC, 5"	1
11	CM-29037	CLAMP, HOSE, 32MM	3
12	SC-22753	SCREW, M6 SS RND SHLDR	2
13	1016831	GC GUIDE, CTC/CTP	1
14	BU-22204	BUSHING, SOCKET, MEMBRANE	1
15	NU-22385	INSERT NUT, THREADED, M5	1
16	SC-47718	SCREW, M5 X 16MM SEMS	4
17	CM-35981	LOOP CLAMP, SURE-GRIP CUSHIONED	1
18	5015021	GREASE CONTAINER ASSEMBLY	1
19	1015416	BRACKET, GC HOSES	1
20	SC-47718	SCREW, M5 X 16MM SEMS	1
21	5033581	WIRE ASSY, 110V-240V (not shown)	1

5034907_0

Grease Collection Package, 230V

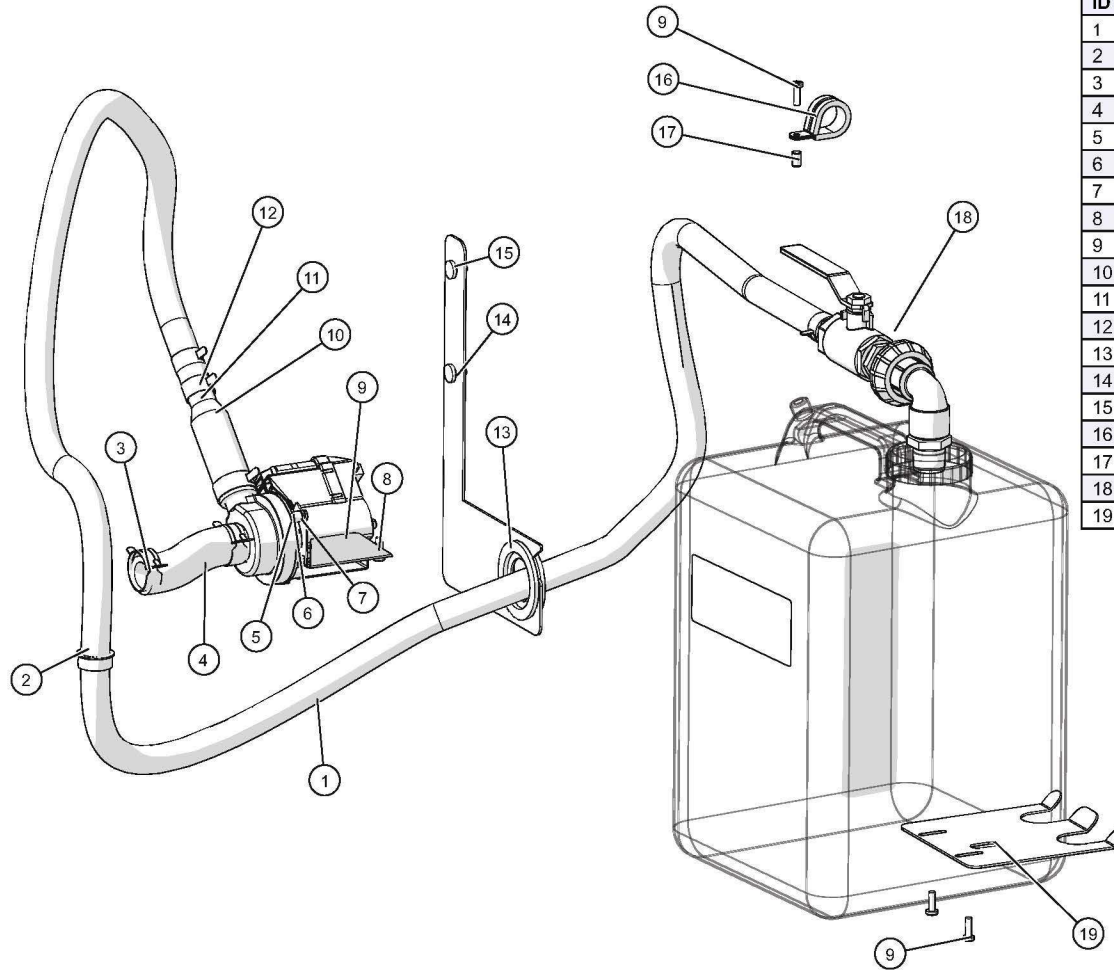

ID	Part No.	Description	Qty
1	HO-28790	HOSE, 0.5" ID, GC, 80"	1
2	BU-3378	1 1/8" SNAP BUSHING	1
3	CM-29037	CLAMP, HOSE, 32MM	3
4	HO-27892	HOSE, 0.875" ID, GC, 5"	1
5	MO-35160	PUMP, WASH SYSTEM, 220V	1
6	SC-22307	SCREW M4.8 X 16mm PHIL PAN HEAD	2
7	WS-22301	WASHER, M5 SPLIT LOCK S/S 18-8	2
8	5015109	BRACKET ASSY, MOTOR MOUNTING	1
9	SC-47718	SCREW, M5 X 16MM SEMS	5
10	PB-29289	REDUCER, 7/8"X1/2"	1
11	CM-29301	CLAMP, HOSE, 23MM	2
12	PB-29489	COUPLER, 1/2" TO 1/2"	1
13	BU-22204	BUSHING, SOCKET, MEMBRANE	1
14	1016831	GC GUIDE, CTC/CTP	1
15	SC-22753	SCREW, M6 SS RND SHLDR	2
16	CM-35981	LOOP CLAMP, SURE-GRIP CUSHIONED	1
17	NU-22385	INSERT NUT, THREADED, M5	1
18	5015021	GREASE CONTAINER ASSY	1
19	1015416	BRACKET, GC HOSES	1

5034908_0

Grease Collection Package, 208-240V

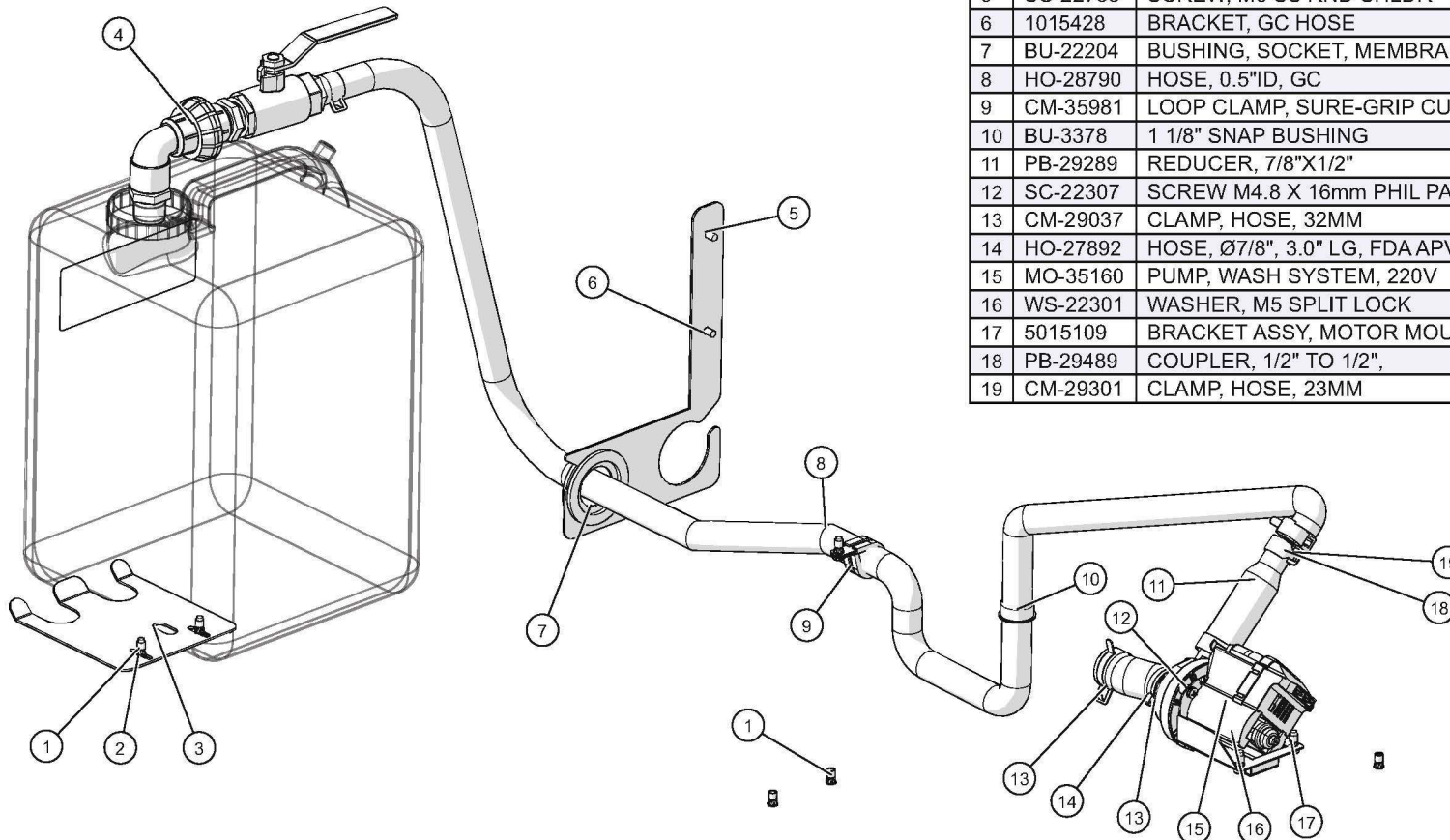

ID	Part No.	Description	Qty
1	NU-23909	NUT, HEX INSERT M5	6
2	SC-47718	SCREW, M5 X 16MM SEMS	5
3	1015416	BRACKET, GC HOSES	1
4	5015021	GREASE CONTAINER, AUX DWG	1
5	SC-22753	SCREW, M6 SS RND SHLDR	2
6	1015428	BRACKET, GC HOSE	1
7	BU-22204	BUSHING, SOCKET, MEMBRANE	1
8	HO-28790	HOSE, 0.5"ID, GC	1
9	CM-35981	LOOP CLAMP, SURE-GRIP CUSHIONED	1
10	BU-3378	1 1/8" SNAP BUSHING	1
11	PB-29289	REDUCER, 7/8"X1/2"	1
12	SC-22307	SCREW M4.8 X 16mm PHIL PAN HEAD	2
13	CM-29037	CLAMP, HOSE, 32MM	3
14	HO-27892	HOSE, Ø7/8", 3.0" LG, FDAAPVD	1
15	MO-35160	PUMP, WASH SYSTEM, 220V	1
16	WS-22301	WASHER, M5 SPLIT LOCK	2
17	5015109	BRACKET ASSY, MOTOR MOUNTING	1
18	PB-29489	COUPLER, 1/2" TO 1/2"	1
19	CM-29301	CLAMP, HOSE, 23MM	2

5034727_1

Liquid Cleaning Package

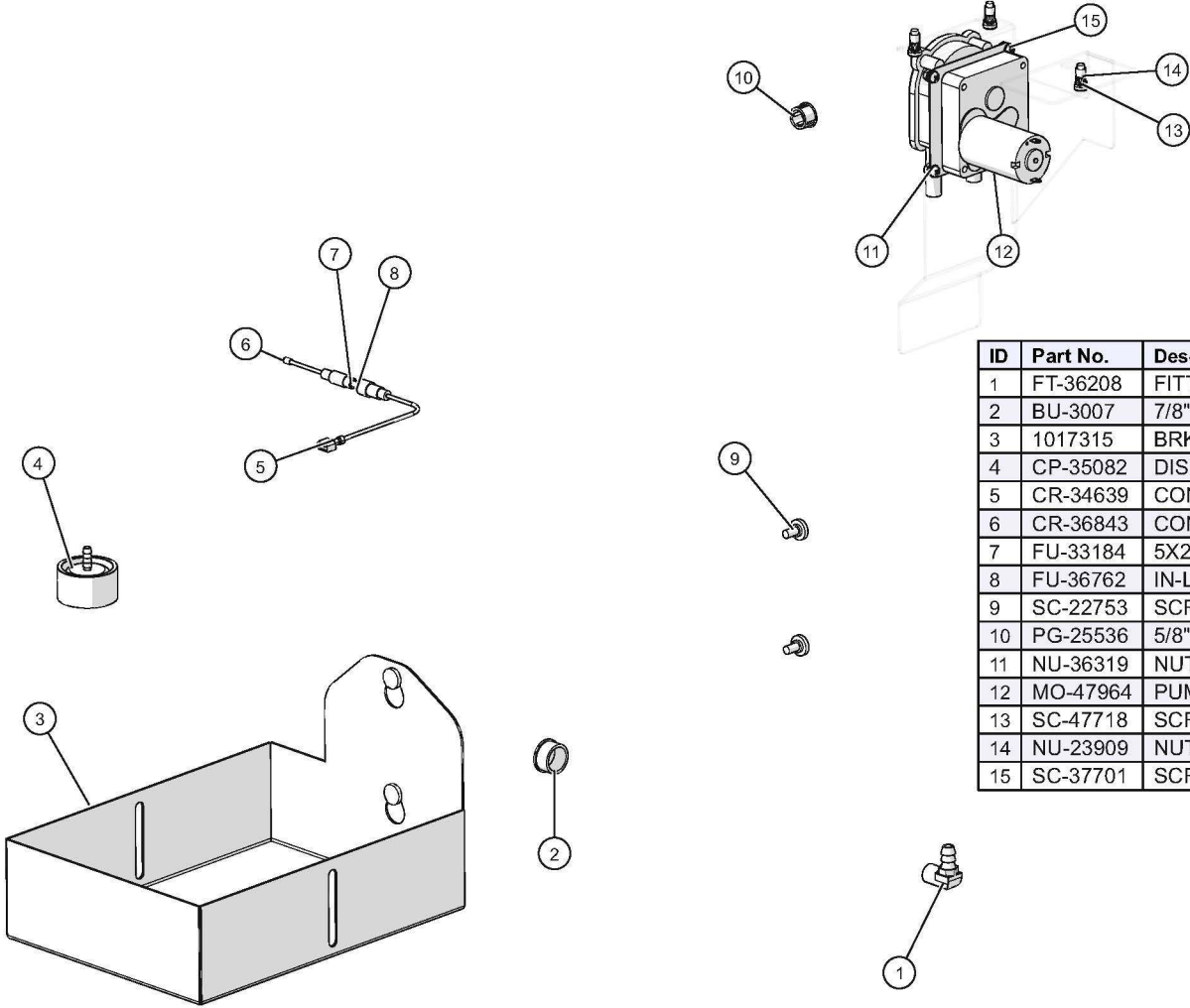

ID	Part No.	Description	Qty
1	FT-36208	FITTING, BARB, 1/4" X 1/4" NFPT	1
2	BU-3007	7/8" SNAP BUSHING, BLACK	1
3	1017315	BRKT, LIQUID CLEANER	1
4	CP-35082	DISPENSING CAP, LIQ CLEANER	1
5	CR-34639	CONNECTOR, QUICK DISCONNECT	1
6	CR-36843	CONNECTOR, INSULATED FERRULE	1
7	FU-33184	5X20MM, SLOW BLO, 2 AMP, 250V	1
8	FU-36762	IN-LINE FUSE HOLDER, 5X20MM 150 SERIES	1
9	SC-22753	SCREW, M6 SS RND SHLDR	4
10	PG-25536	5/8" HOLE PLUG	1
11	NU-36319	NUT, M4, KEPS, ZINC PLATED	4
12	MO-47964	PUMP, LIQUID CLEANER, 12VDC	1
13	SC-47718	SCREW, M5 X 16MM SEMS	3
14	NU-23909	NUT, HEX INSERT M5	3
15	SC-37701	SCREW, M4 X 8MM SEMS	4

5035016_1

Hose Package, Liquid Soap Injection

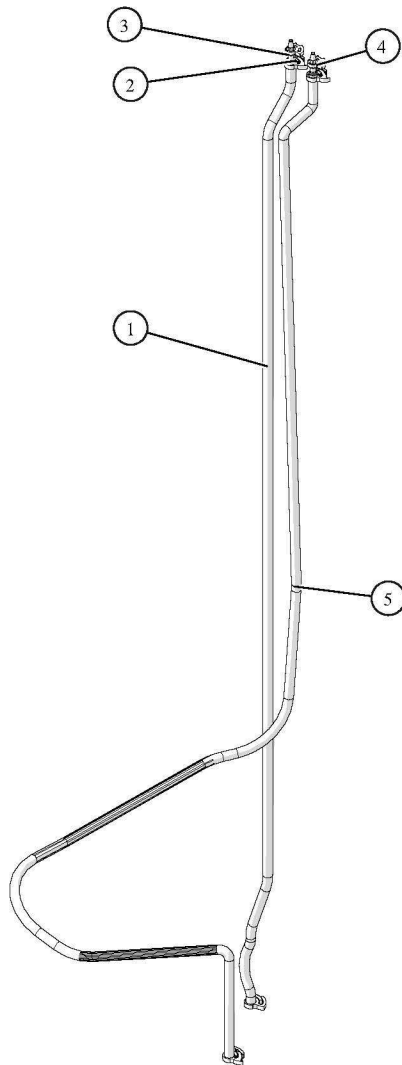

ID	Part No.	Description	Qty
1	HO-37315	HOSE, 1/4" ID, 20.20 LSI	1
2	CM-46802	CLAMP,EAR,PINCH,9/32" BANDS"	4
3	FT-46342	CONNECTOR, PLASTIC 1/4"	2
4	CM-46802	CLAMP,EAR,PINCH,9/32" BANDS"	2
5	HO-37315	HOSE, 1/4" ID, 20.20 INLET LSI	1

5016809_10

No Liquid Soap Injection Package

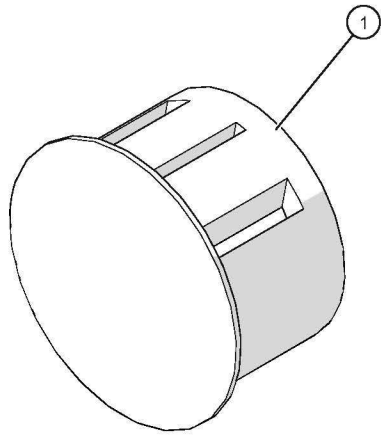

ID	Part No.	Description	Qty
1	PG-25536	5/8" HOLE PLUG	1
2	PG-29895	NPT PIPE PLUG, HEX HEAD, 1/4"	1

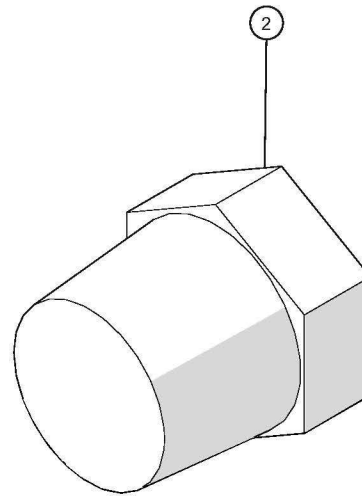

5016317_17

Service Kit, N6 Temperature Sensor

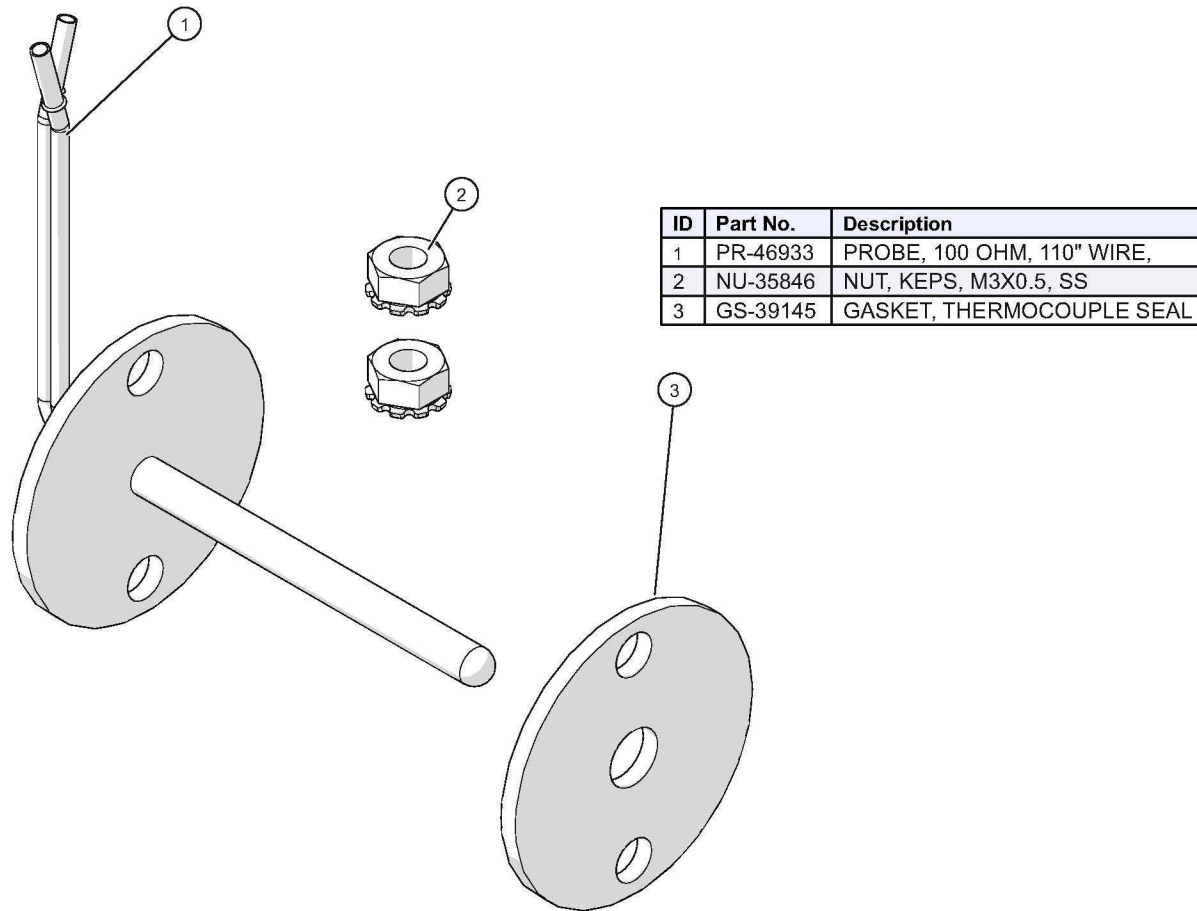

5035208_1

Service Kit, Pro, Ampire Display

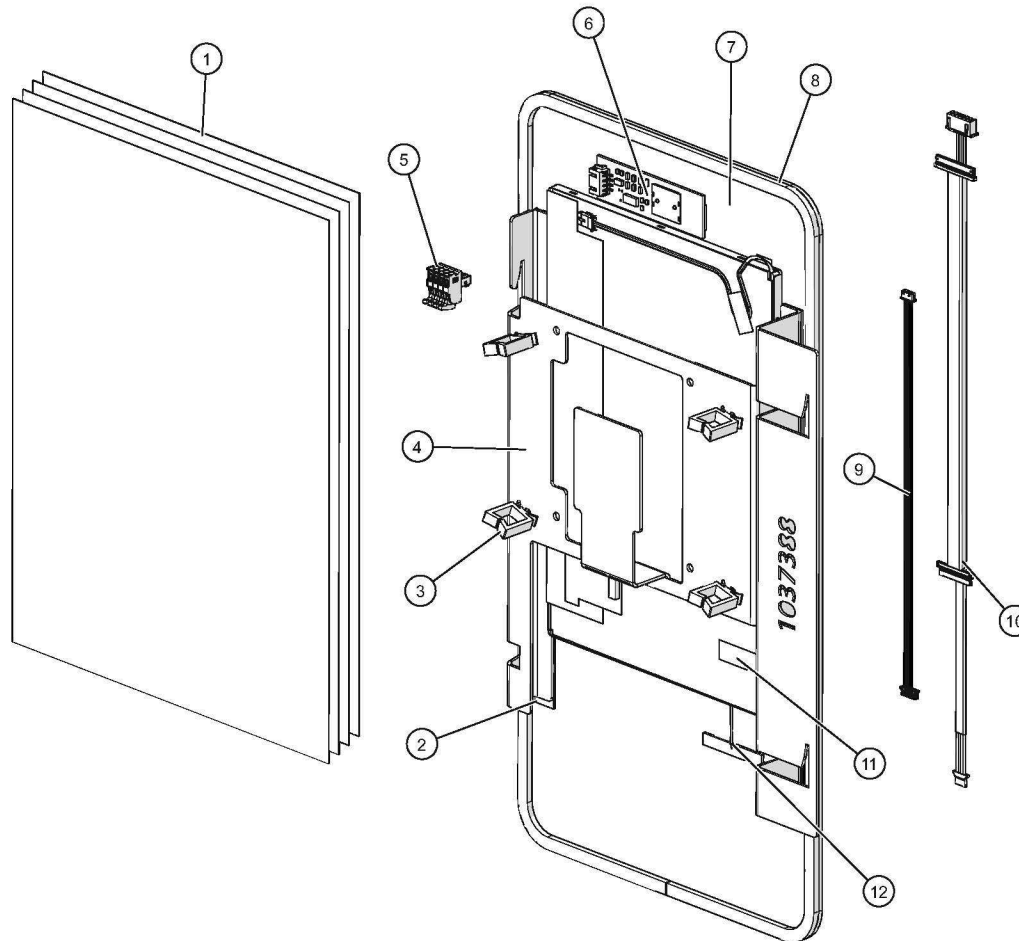

ID	Part No.	Description	Qty
1	SRV-20201	SERVICE DOC, LCD DISPLAY	1
2	TA-46816	1/2" VHB TAPE, 1mm THK	4
3	CL-38422	RETAINER, WIRE, SQUARE, PUSH IN	4
4	1037388	BRKT, MOUNTING, CNTRL, AMPIRE	1
5	TM-34881	TERMINAL, 3.5MM PLUGGABLE, 4 POLE	1
6	CC-39975	BOARD, ON/OFF BUTTON, PCAP	1
7	5036053	ASSY, GLASS W/ 10.1" LCD, AMPIRE	1
8	GS-23622	GASKET, EPDM FOAM, 3.75 FT LONG	1
9	CB-39912	CABLE, PCAP	1
10	CB-46664	CABLE, LVDS & BL, AMPIRE	1
11	TA-46558	TAPE, SHIELDING, COND., 2" LONG	1
12	CC-46559	ANTENNA, WIFI CONTROL	1
13	CB-34917	CABLE, ON-OFF/BOARD, TOUCH (not shown)	1

5036055_0

Service Kit, Classic Display

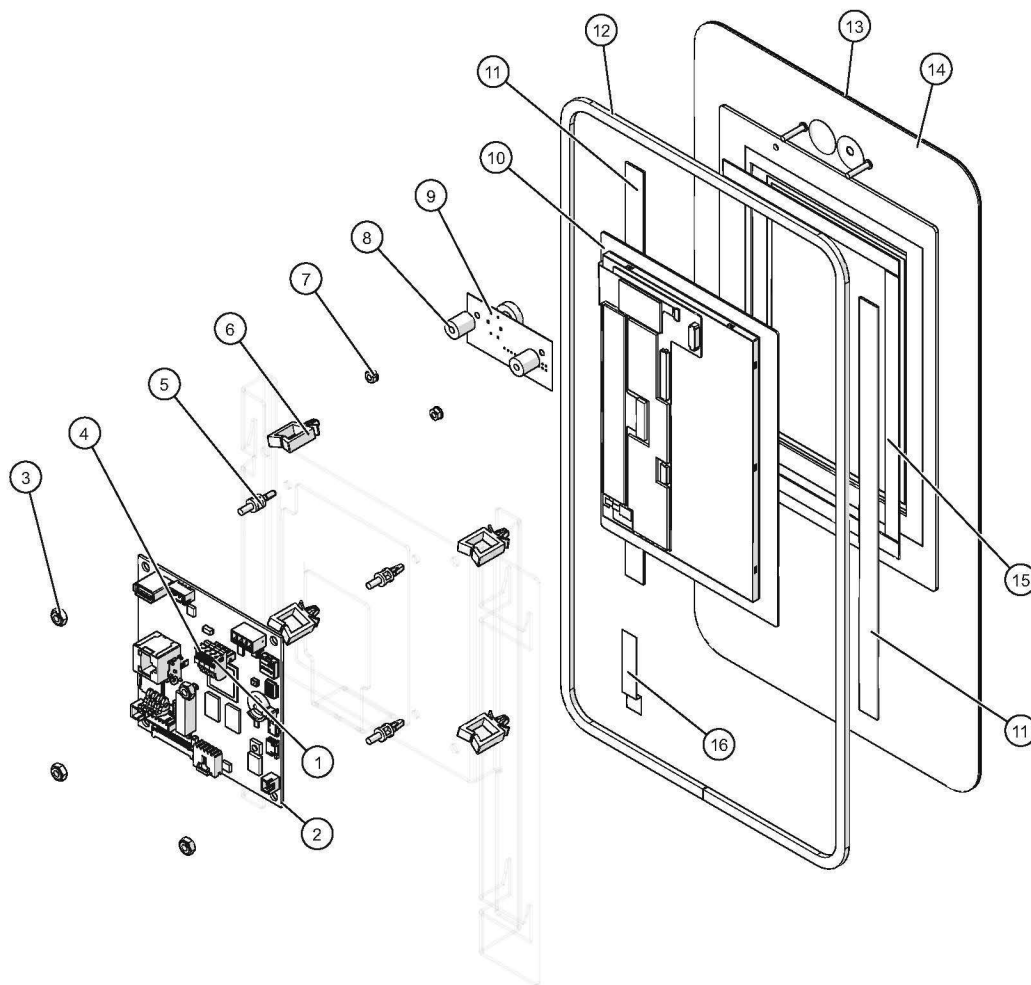

ID	Part No.	Description
1	TM-34881	TERMINAL, 3.5MM PLUGGABLE, 4 POLE
2	5035864	SVC KIT, INTERFACE BOARD
3	NU-39735	NUT,HEX,6-32,NYLON
4	CC-48185	CONTROL, CARD W/ FILE SYSTEM,
5	SP-33902	SPACER, 1/4", CIRCUIT BRD
6	CL-38422	RETAINER,WIRE,SQUARE,PUSH IN
7	NU-35846	NUT, KEPS, M3X0.5, SS
8	BU-25094	BUSHING,*CT,ML,BRASS,DISTANCE
9	CC-36871	BOARD, ON/OFF, ONE BUTTON
10	5035214	SVC KIT, CLASSIC DISPLAY
11	TA-46816	1/2" VHB TAPE,1mm THK,10" LG
12	GS-23622	GASKET,EPDM FOAM,3.75 FT LONG
13	PE-47629	PANEL,OVERLAY
14	5033263	CONTROL,WELDMENT
15	TA-37219	TAPE,.375" W X 0.032" X 16.25"
16	TA-46558	TAPE,SHIELDING,COND., 2" LONG

5033266_5

Service Kit, Control Board, DC

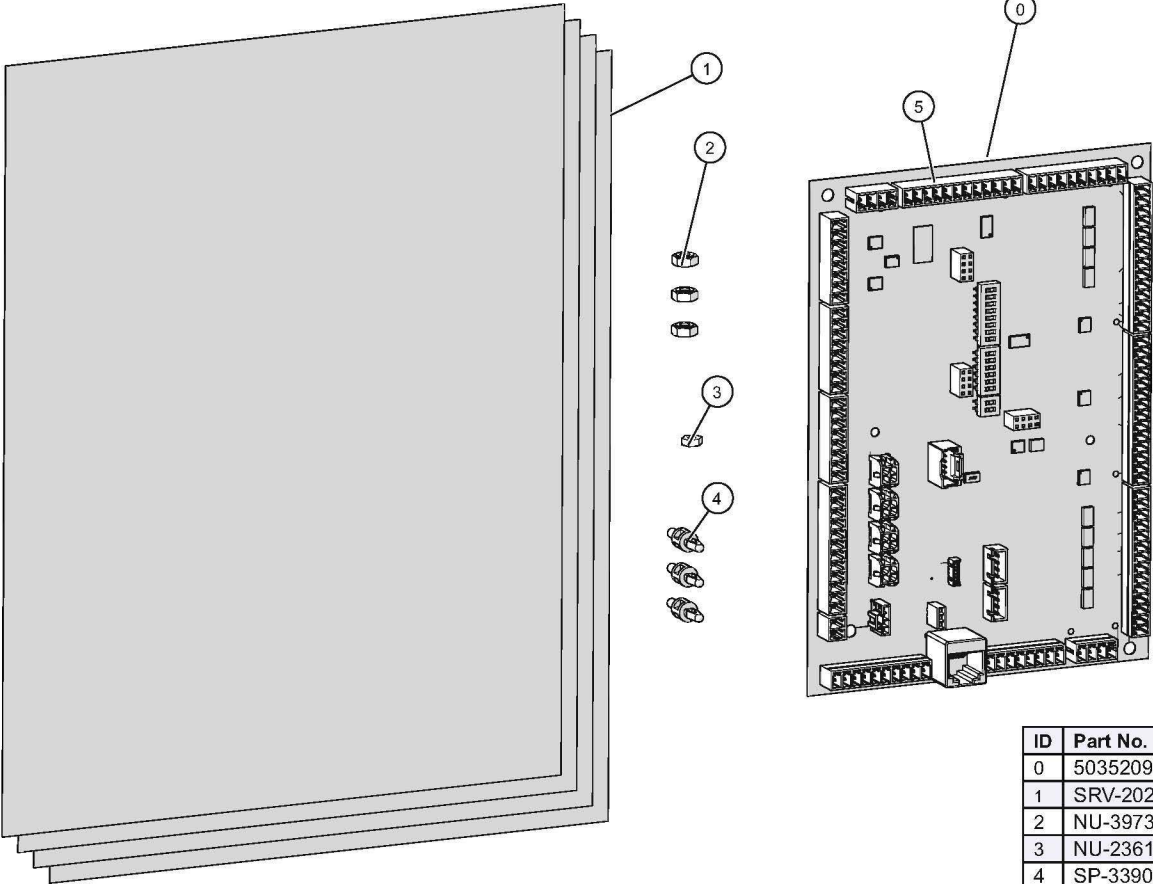

ID	Part No.	Description	Qty
0	5035209	KIT,SERVICE,CONTROL BOARD,DC	1
1	SRV-20200	SERVICE DOC, CB, RB, REPLACE	1
2	NU-39735	NUT,HEX,6-32,NYLON	3
3	NU-2361	NUT, 6-32 HEX, S/S	1
4	SP-33902	SPACER, 1/4", CIRCUIT BRD	3
5	CC-47035	CONTROL BOARD,COMBI,W/FIRM,	1

5035209_0

Service Kit, Relay Board

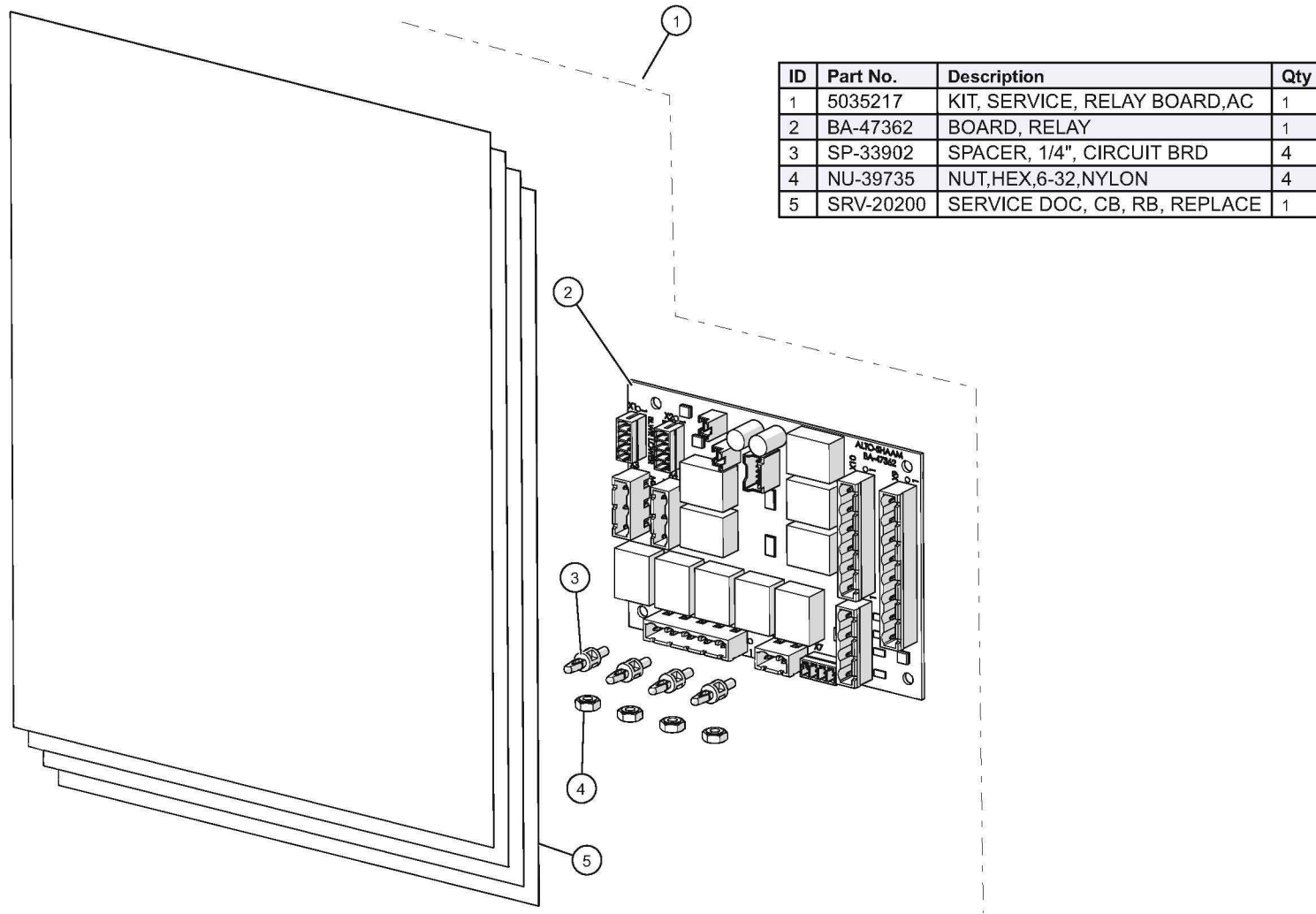

5035217_0

Service Kit, Option Board

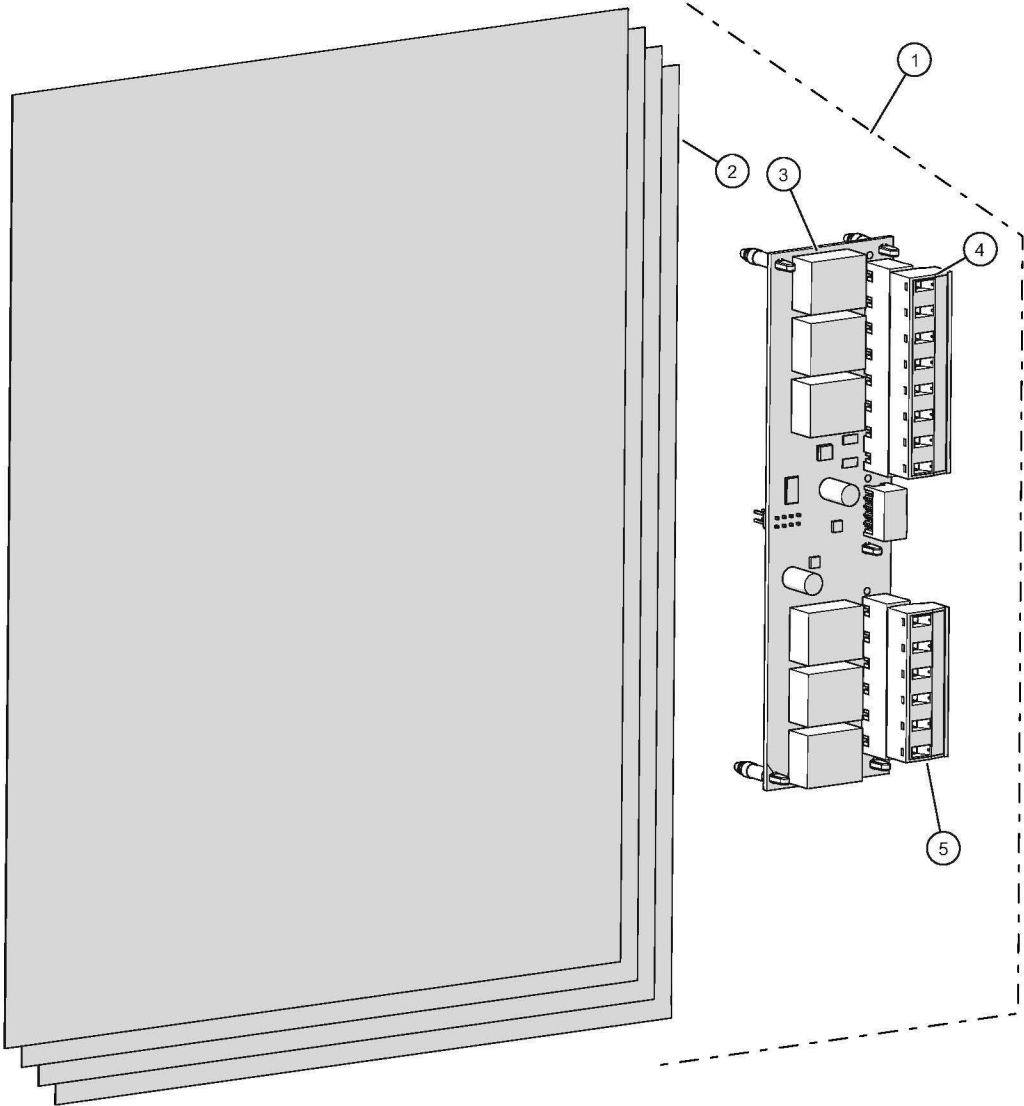

ID	Part No.	Description
1	5033966R	KIT,SERVICE,OPTION BOARD,AC/DC
2	SRV-20202	SERVICE DOC, OPTION BOARD
3	BA-47405	BOARD, OPTION
4	TM-47676	TERMINAL, 8 POS, GREEN
5	TM-47677	TERMINAL, 6 POS, GREEN

5033966_1

Electrical Chassis, G, 120V DX 20-10

ID	Part No.	Description	Qty
1	5033455	RELAY BOARD,CONTROL,ASSY	1
2	5034973	PANEL ASSY,ELECTRICAL CHASSIS	1
3	FA-3599	FAN, TUBEAXIAL, 115V 70 CFM	1
4	CB-39799	CABLE, CONVERSION, DUAL	1
5	FI-33225	FILTER LINE 115/250V 50/60HZ	2
6	CR-34639	CONNECTOR, QUICK DISCONNECT	3
7	FU-47934	FUSE, 1A, 250V,FAST ACTING,	2
8	FU-36762	IN-LINE FUSE HOLDER, 5X20MM 150 SERIES	3
9	CR-36843	CONNECTOR, INSULATED FERRULE	2
10	FU-46554	FUSE, 630mA, 250V,FAST ACTING,	1
11	SC-37701	SCREW, M4 X 8MM SEMS	4
12	CL-47555	PUSH IN WIRE RETAINER	13

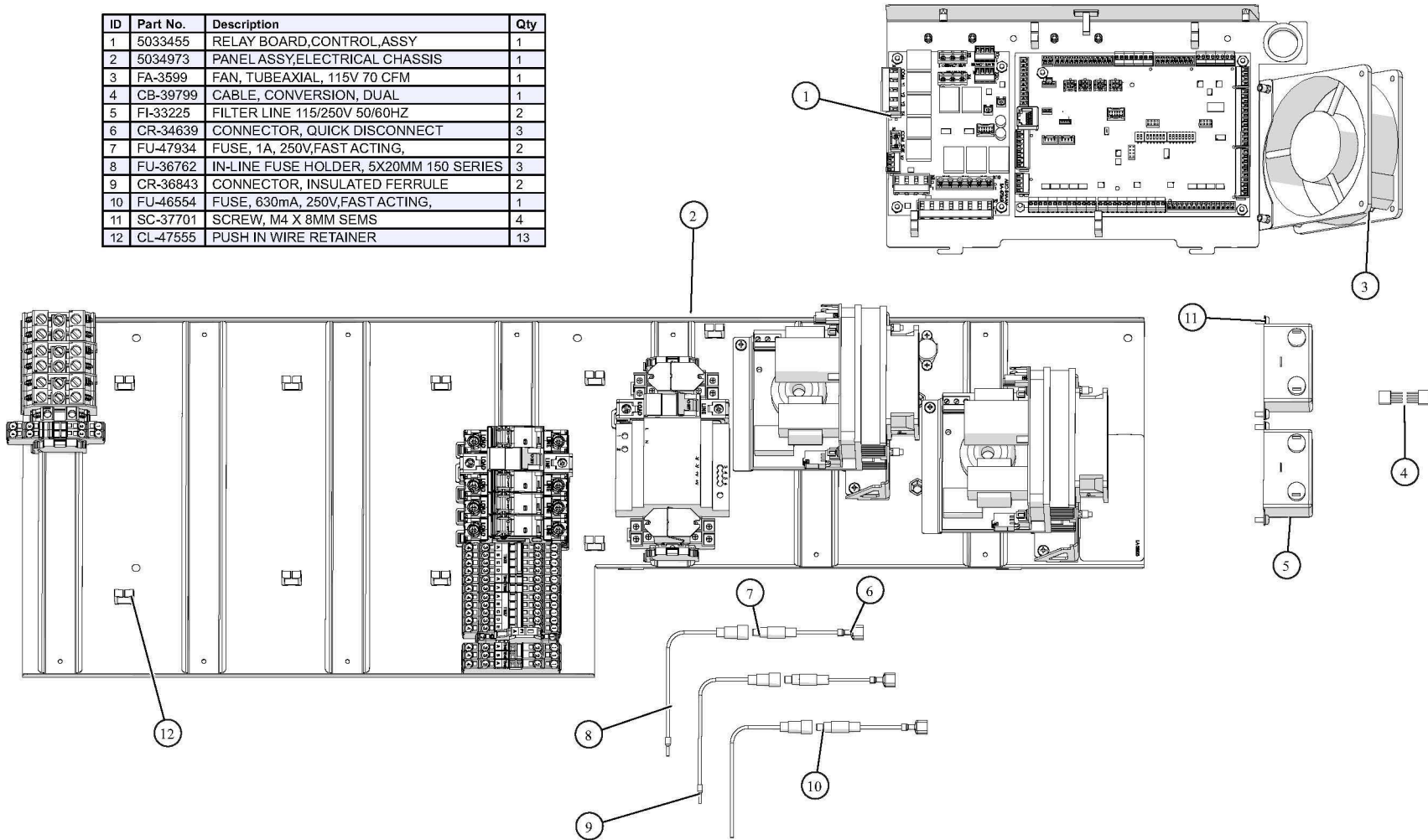

5035081_4

Electrical Chassis, G, 120V DX 20-10—Relay Board Assembly

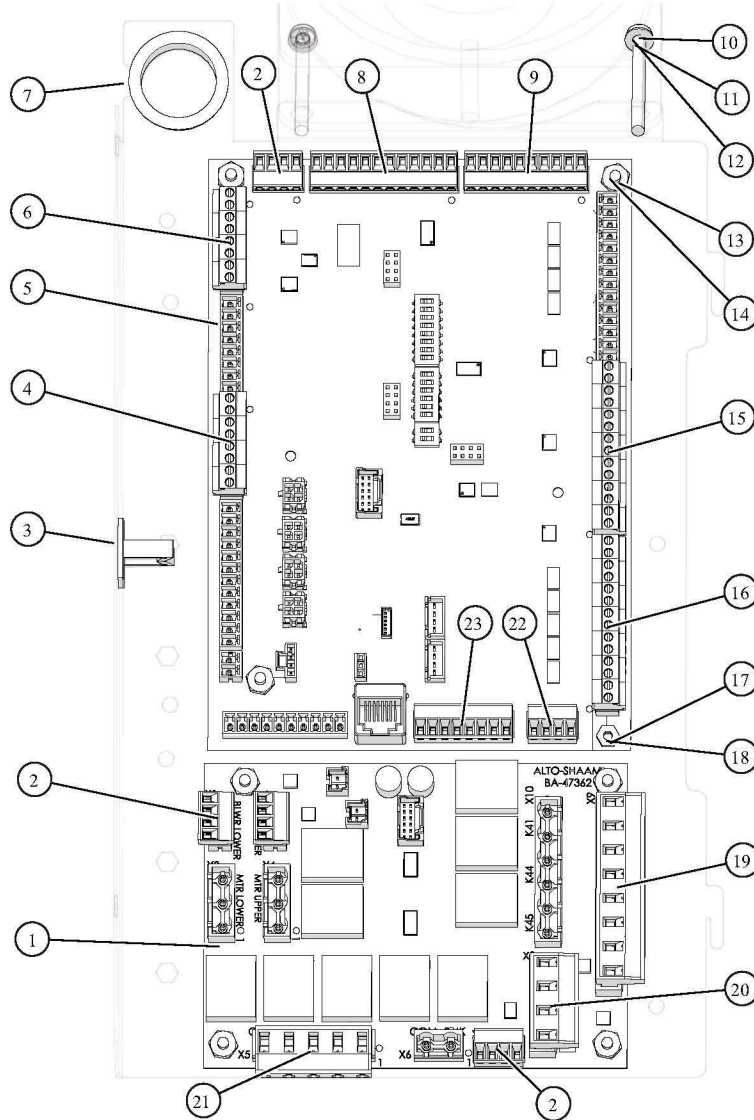

ID	Part No.	Description	Qty
1	BA-47362	BOARD, RELAY	1
2	TM-47576	TERMINAL, WHITE, 4 PIN	4
3	CM-38423	ADHESIVE WIRE RETAINER	1
4	CR-46948	CONNECTOR, 8 POS, GREEN	1
5	CC-48196	CONTROL BOARD,WITH FIRMWARE	1
6	CR-46946	CONNECTOR, 8 POS, BLACK	1
7	BU-3378	1 1/8" SNAP BUSHING	1
8	TM-47580	TERMINAL, BLUE, 12 PIN	1
9	TM-47680	TERMINAL, BLACK, 10 PIN	1
10	SC-29261	SCREW,M4x0.7X50MM PAN	2
11	WS-22294	WASHER, FLAT M4 18-8 S/S	2
12	WS-22300	WASHER, M4 SPLIT LOCK	2
13	SP-33902	SPACER, 1/4", CIRCUIT BRD	7
14	NU-39735	NUT,HEX,6-32,NYLON	7
15	CR-46951	CONNECTOR, 14 POS, BLUE	1
16	CR-46952	CONNECTOR, 14 POS, GREEN	1
17	SP-38839	SPACER,M4,4 ID x 6 OD x 6MM LG	1
18	NU-2361	NUT, 6-32 HEX, S/S	1
19	TM-47676	TERMINAL, 8 POS, GREEN	1
20	TM-47679	TERMINAL, 4 POS, GREEN	1
21	TM-47678	TERMINAL, 5 POS, GREEN	1
22	TM-47577	TERMINAL, GREY, 4 PIN	1
23	TM-47578	TERMINAL, ORANGE, 8 PIN	1

5035081DV1_4

Electrical Chassis, G, 120V DX 20-10—Panel Assembly

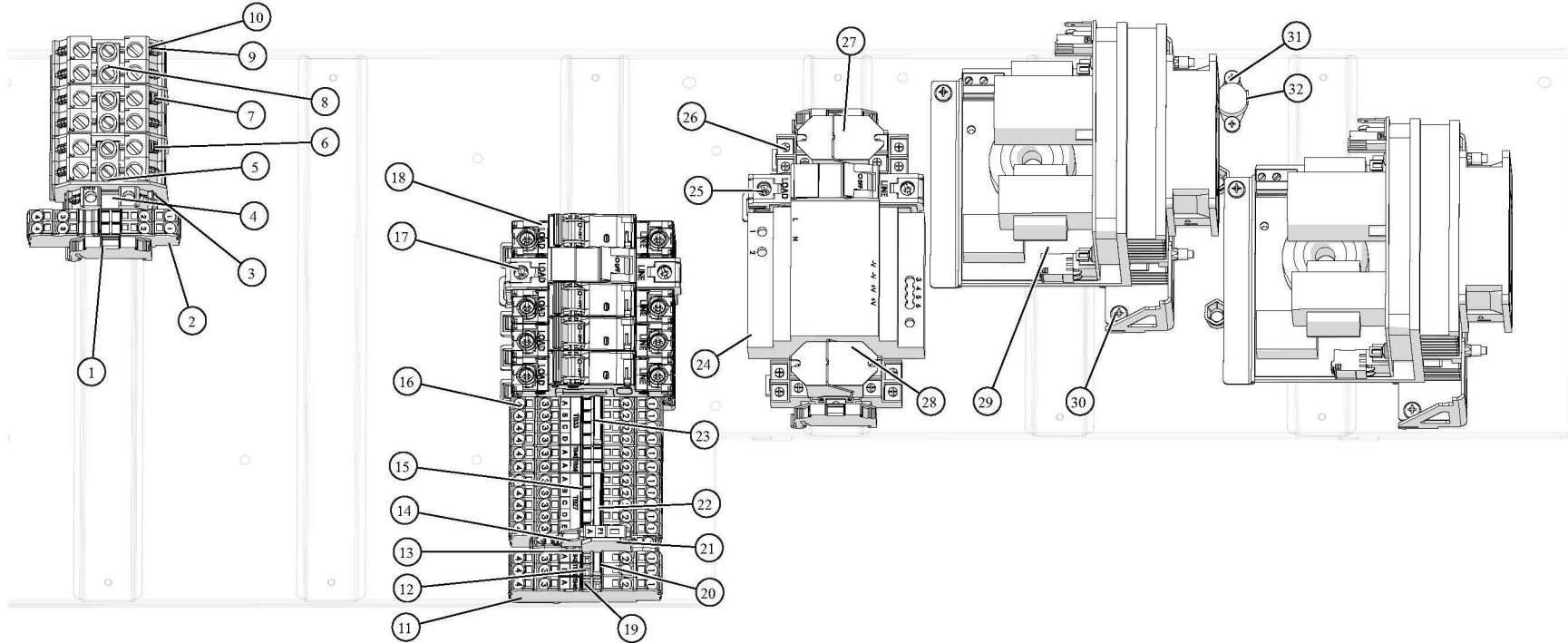

ID	Part No.	Description	Qty
1	TM-39606	TERMINAL, SCREWLESS END	4
2	TM-39579	TERMINAL, GROUND, 6mm, SPRING	2
3	TM-47504	TERMINAL, GROUND, 10MM, 1000V	1
4	TM-47503	END PLATE, 12MM TERMINAL	3
5	TM-47501	TERMINAL, 12MM, 71A, 1000V	6
6	TM-3792	TERMINALS, MARK, 3	1
7	TM-3791	TERMINALS, MARK, 2	1
8	TM-47502	CONNECTOR, CROSS, 2-POLE, 12M	3
9	TM-3790	TERMINALS, MARK, 1	1
10	TM-3788	TERMINALS, MARK, L	3
11	TM-39576	TERMINAL, END SECTION, SPRING	7

ID	Part No.	Description	Qty
12	TM-47638	TERMINAL, 4mm, GRAY, 4-CONDUCTOR	2
13	TM-39578	TERMINAL, END PLATE	1
14	TM-39577	TERMINAL, FUSE HOLDER	1
15	TM-39575	TERMINAL, 6mm, BLUE, SPRING	6
16	TM-39574	TERMINAL, 6mm, ORANGE, SPRING	5
17	FU-39058	CIRCUIT BREAKER, 20A	1
18	FU-46810	CIRCUIT BREAKER, 15A	4
19	TM-47182	TERMINAL, 4mm, BLACK, 4-CONDUCTOR	1
20	TM-39585	JUMPER, 2 POLE	1
21	FU-36668	5X20MM, SLOW BLO, 5AMP, 250V	1
22	TM-39582	JUMPER, 5 POLE	1

ID	Part No.	Description	Qty
23	TM-39583	JUMPER, 4 POLE	1
24	BA-46801	POWER SUPPLY, 12VDC, 100W	1
25	FU-47665	CIRCUIT BREAKER, 8A	1
26	RL-34634	UNIVERSAL MOUNTING SOCKET	2
27	RL-33930	RELAY, 12VDC, 15A, 8 PINS	2
28	RL-37266	SPRING, HOLD DOWN	2
29	BA-39795	BOARD, VF MOTOR DRIVE	2
30	SC-37701	SCREW, M4 X 8MM SEMS	4
31	SC-38693	SCREW, #8-18 X 1/2", PHIL, PAN	2
32	TT-36119	THERMOSTAT, BI-METAL, 100 DEG CLOSE	1

5035081DV2_4

Electrical Chassis, G, 120V SX 20-10

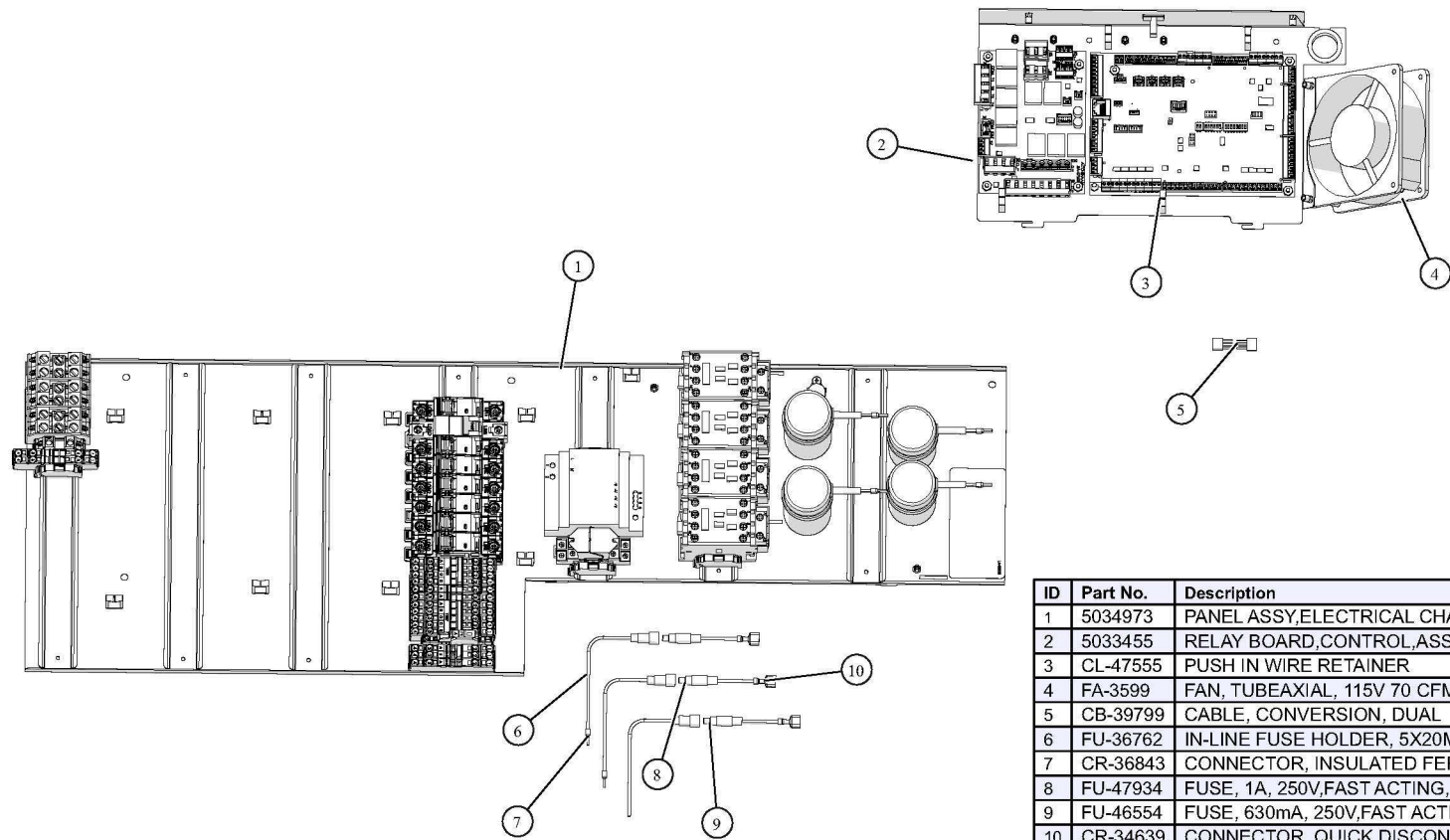

ID	Part No.	Description	Qty
1	5034973	PANEL ASSY,ELECTRICAL CHASSIS	1
2	5033455	RELAY BOARD,CONTROL,ASSY	1
3	CL-47555	PUSH IN WIRE RETAINER	13
4	FA-3599	FAN, TUBEAXIAL, 115V 70 CFM	1
5	CB-39799	CABLE, CONVERSION, DUAL	1
6	FU-36762	IN-LINE FUSE HOLDER, 5X20MM 150 SERIES	3
7	CR-36843	CONNECTOR, INSULATED FERRULE	2
8	FU-47934	FUSE, 1A, 250V,FAST ACTING,	2
9	FU-46554	FUSE, 630mA, 250V,FAST ACTING,	1
10	CR-34639	CONNECTOR, QUICK DISCONNECT	3

5035203_3

Electrical Chassis, G, 120V SX 20-10—Relay Board Assembly

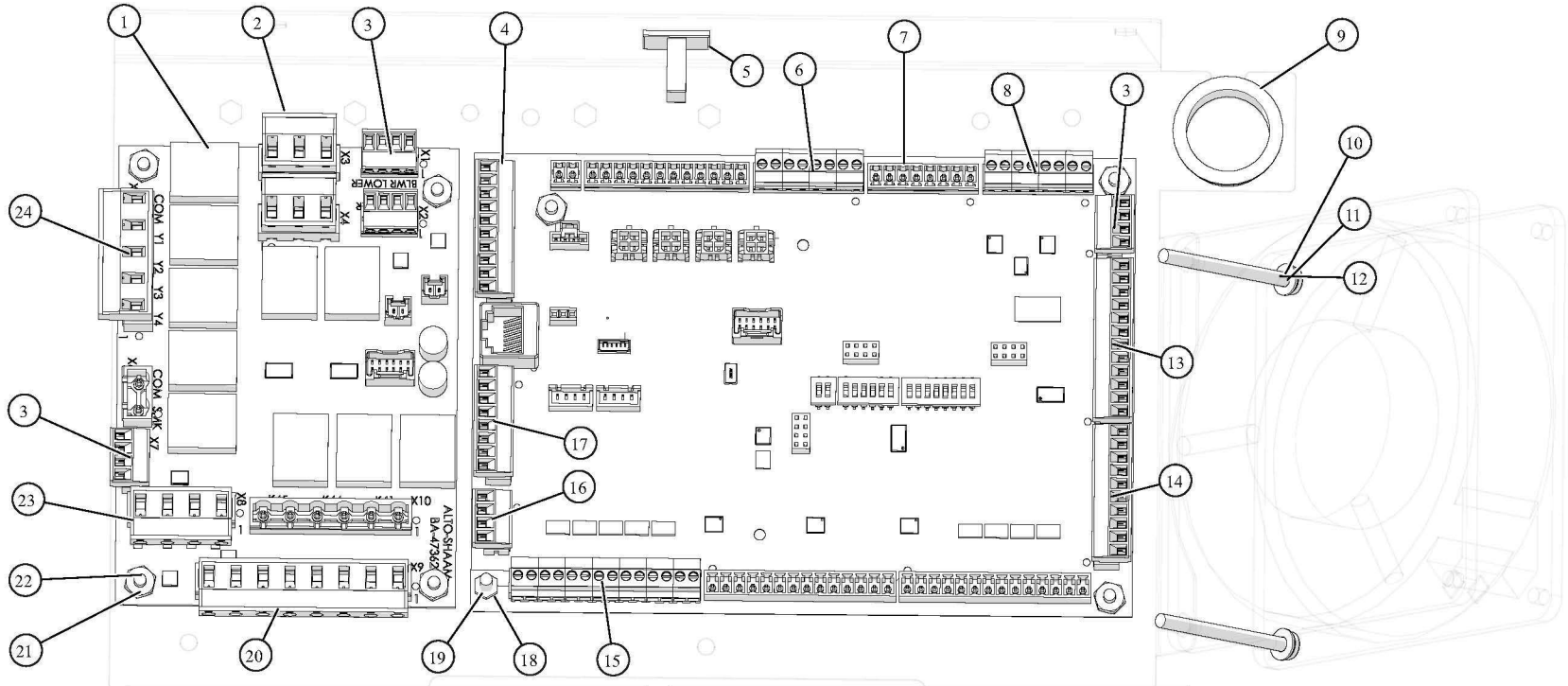

ID	Part No.	Description	Qty
1	BA-47362	BOARD, RELAY	1
2	TM-47674	TERMINAL, 3 POS, GREEN	2
3	TM-47576	TERMINAL, WHITE, 4 PIN	4
4	TM-47579	TERMINAL, BLUE, 10 PIN	1
5	CM-38423	ADHESIVE WIRE RETAINER	1
6	CR-46948	CONNECTOR, 8 POS, GREEN	1
7	CC-48196	CONTROL BOARD, WITH FIRMWARE	1
8	CR-46946	CONNECTOR, 8 POS, BLACK	1
9	BU-3378	1 1/8" SNAP BUSHING	1
10	WS-22300	WASHER, M4 SPLIT LOCK	2
11	SC-29261	SCREW, M4x0.7X50MM PAN	2
12	WS-22294	WASHER, FLAT M4 18-8 S/S	2
13	TM-47580	TERMINAL, BLUE, 12 PIN	1

ID	Part No.	Description	Qty
14	TM-47680	TERMINAL, BLACK, 10 PIN	1
15	CR-46952	CONNECTOR, 14 POS, GREEN	1
16	TM-47577	TERMINAL, GREY, 4 PIN	1
17	TM-47578	TERMINAL, ORANGE, 8 PIN	1
18	SP-38839	SPACER, M4, 4 ID x 6 OD x 6MM LG	1
19	NU-2361	NUT, 6-32 HEX, S/S	1
20	TM-47676	TERMINAL, 8 POS, GREEN	1
21	SP-33902	SPACER, 1/4", CIRCUIT BRD	7
22	NU-39735	NUT, HEX, 6-32, NYLON	7
23	TM-47679	TERMINAL, 4 POS, GREEN	1
24	TM-47678	TERMINAL, 5 POS, GREEN	1

5035203DV1_3

Electrical Chassis, G, 120V SX 20-10—Panel Assembly

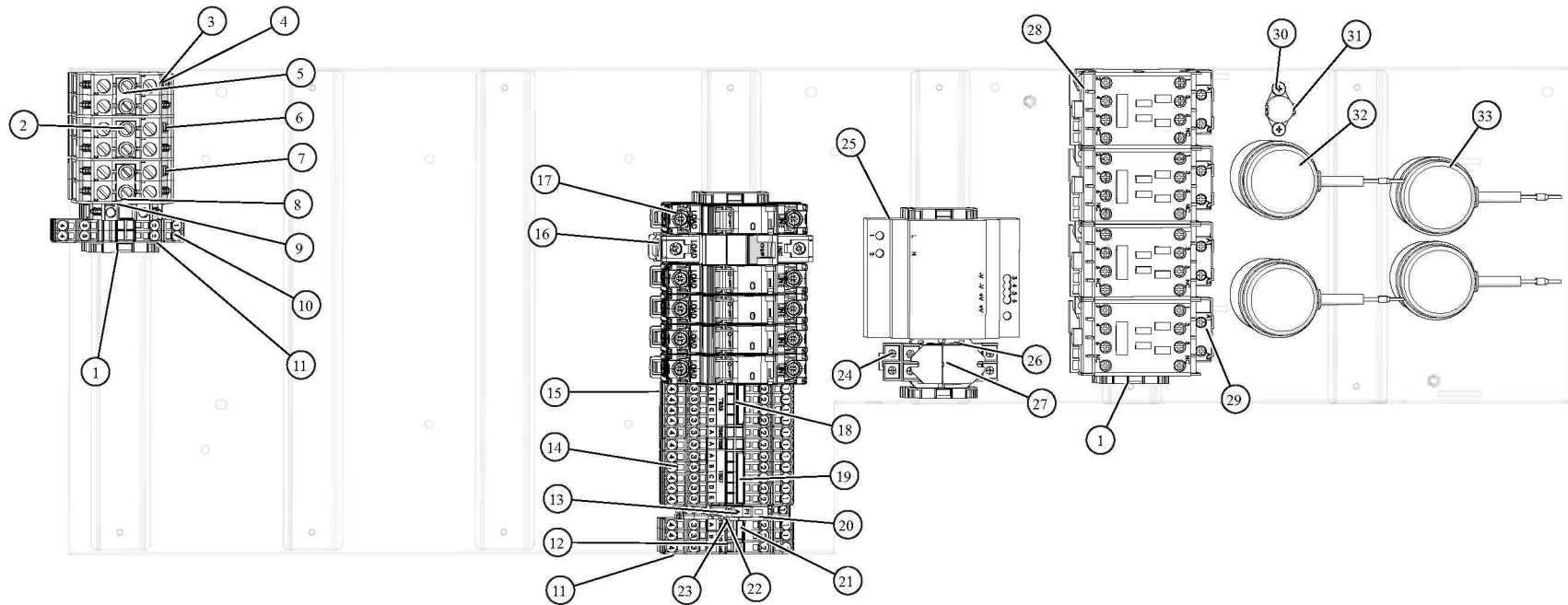

ID	Part No.	Description	Qty
1	TM-39606	TERMINAL, SCREWLESS END	5
2	TM-47501	TERMINAL, 12MM, 71A, 1000V	6
3	TM-3788	TERMINALS, MARK, L	3
4	TM-3790	TERMINALS, MARK, 1	1
5	TM-47502	CONNECTOR, CROSS, 2-POLE, 12M	3
6	TM-3791	TERMINALS, MARK, 2	1
7	TM-3792	TERMINALS, MARK, 3	1
8	TM-47503	END PLATE, 12MM TERMINAL	3
9	TM-47504	TERMINAL, GROUND, 10MM, 1000V	1
10	TM-39579	TERMINAL, GROUND, 6mm, SPRING	2
11	TM-39576	TERMINAL, END SECTION, SPRING	7
12	TM-47182	TERMINAL, 4mm, BLACK, 4-CONDUCTOR	1

ID	Part No.	Description	Qty
13	TM-39577	TERMINAL, FUSE HOLDER,	1
14	TM-39575	TERMINAL, 6mm, BLUE, SPRING	6
15	TM-39574	TERMINAL, 6mm, ORANGE, SPRING	5
16	FU-39058	CIRCUIT BREAKER, 20A	1
17	FU-46810	CIRCUIT BREAKER, 15A	5
18	TM-39583	JUMPER, 4 POLE	1
19	TM-39582	JUMPER, 5 POLE	1
20	FU-36668	5X20MM, SLOW BLO, 5AMP, 250V	1
21	TM-39585	JUMPER, 2 POLE	1
22	TM-39578	TERMINAL, END PLATE	1
23	TM-47638	TERMINAL, 4mm, GRAY, 4-CONDUCTOR	2
24	RL-34634	UNIVERSAL MOUNTING SOCKET	1

ID	Part No.	Description	Qty
25	BA-46801	POWER SUPPLY, 12VDC, 100W	1
26	RL-37266	SPRING, HOLD DOWN,	1
27	RL-33930	RELAY, 12VDC, 15A, 8 PINS	1
28	CN-47698	CONTACTOR, 120V, 32A, SCREW	4
29	FI-33990	EMI FILTER	4
30	SC-38693	SCREW, #8-18 X 1/2", PHIL, PAN	2
31	TT-36119	THERMOSTAT, BI-METAL, 100 DEG CLOSE	1
32	MO-34393	CAPACITOR, MOTOR, 40 MFD, 240VAC	2
33	MO-34394	MOTOR, CAPACITOR, 20 UF, 240VAC	2

5035203DV2_3

Electrical Chassis, E, 208-240V DX 20-10

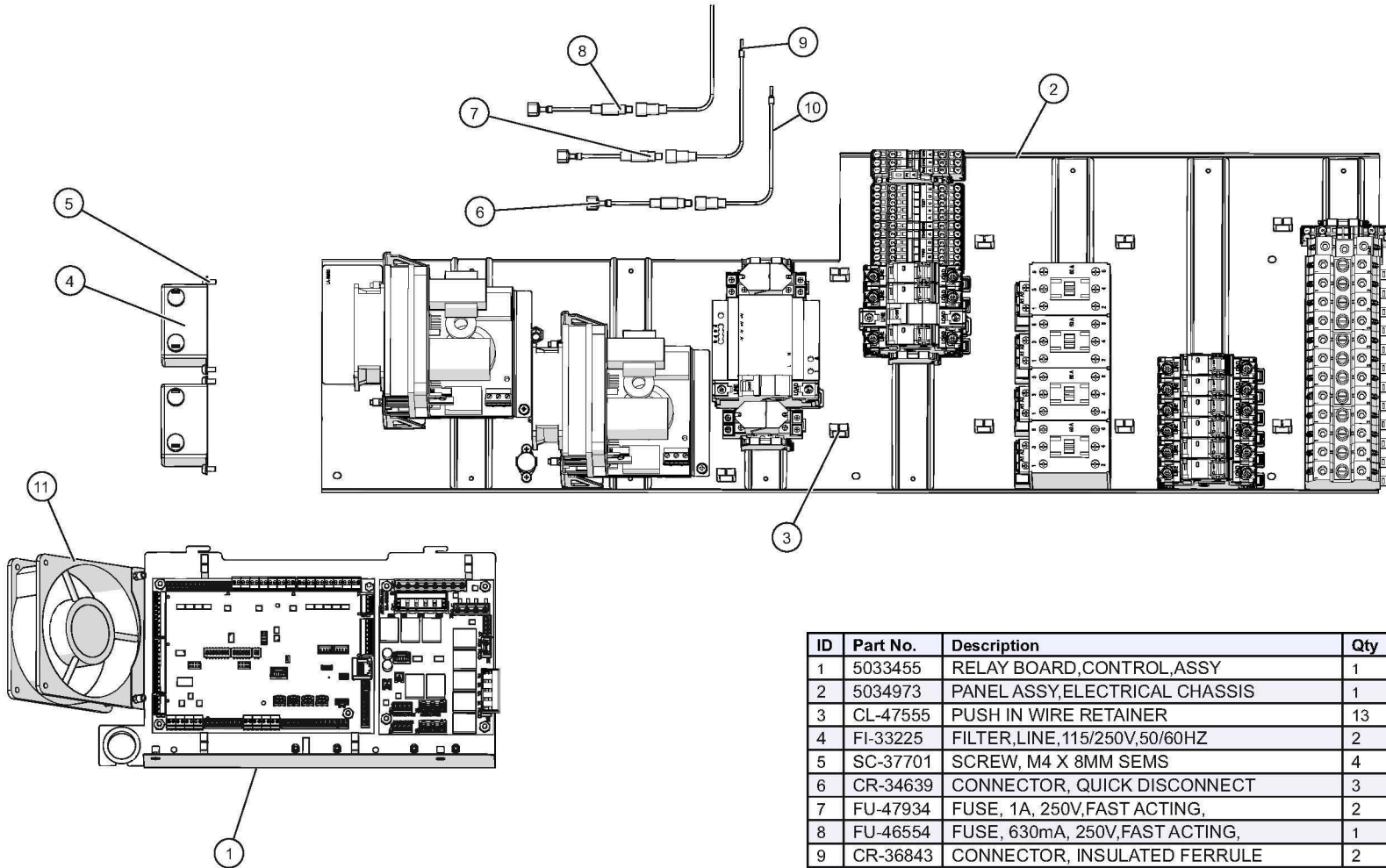

ID	Part No.	Description	Qty
1	5033455	RELAY BOARD,CONTROL,ASSY	1
2	5034973	PANEL ASSY,ELECTRICAL CHASSIS	1
3	CL-47555	PUSH IN WIRE RETAINER	13
4	FI-33225	FILTER,LINE,115/250V,50/60HZ	2
5	SC-37701	SCREW, M4 X 8MM SEMS	4
6	CR-34639	CONNECTOR, QUICK DISCONNECT	3
7	FU-47934	FUSE, 1A, 250V,FAST ACTING,	2
8	FU-46554	FUSE, 630mA, 250V,FAST ACTING,	1
9	CR-36843	CONNECTOR, INSULATED FERRULE	2
10	FU-36762	IN-LINE FUSE HOLDER, 5X20MM 150 SERIES	3
11	FA-3568	FAN HOUSING, 119mm x 119mm x 38mm	1

5035207_2

Electrical Chassis, E, 208-240V DX 20-10—Relay Board Detail

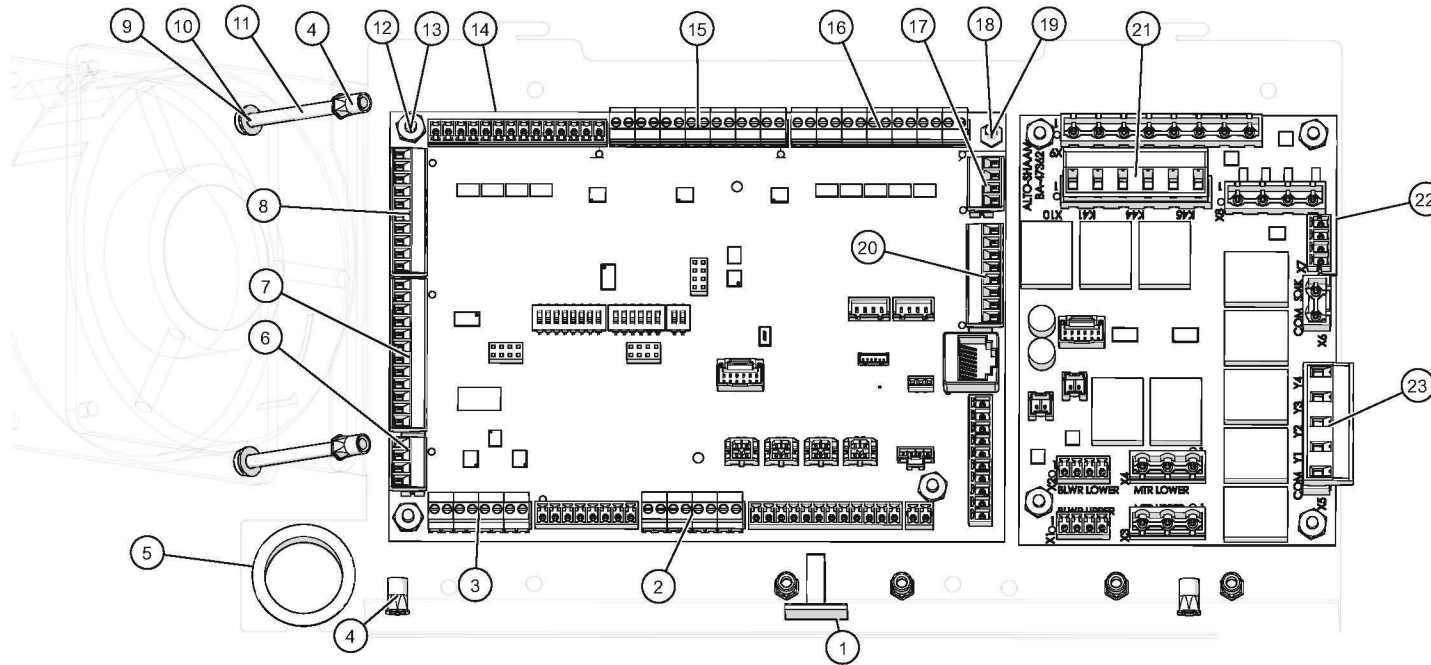

ID	Part No.	Description	Qty
1	CM-38423	ADHESIVE WIRE RETAINER	1
2	CR-46948	CONNECTOR, 8 POS, GREEN	1
3	CR-46946	CONNECTOR, 8 POS, BLACK	1
4	NU-26866	NUT, HEX INSERT M4	8
5	BU-3378	1 1/8" SNAP BUSHING	1
6	TM-47576	TERMINAL, WHITE, 4 PIN	1
7	TM-47580	TERMINAL, BLUE, 12 PIN	1
8	TM-47680	TERMINAL, BLACK, 10 PIN	1
9	WS-22294	WASHER, FLAT M4 18-8 S/S	2
10	WS-22300	WASHER, M4 SPLIT LOCK	2
11	SC-29261	SCREW, M4x0.7X50MM PAN	2
12	SP-33902	SPACER, 1/4", CIRCUIT BRD	7

ID	Part No.	Description	Qty
13	NU-39735	NUT, HEX, 6-32, NYLON	7
14	BA-46624	COMBI MULTI COOK CONTROL	1
15	CR-46951	CONNECTOR, 14 POS, BLUE	1
16	CR-46952	CONNECTOR, 14 POS, GREEN	1
17	TM-47577	TERMINAL, GREY, 4 PIN	1
18	SP-38839	SPACER, M4, 4 ID x 6 OD x 6MM LG	1
19	NU-2361	NUT, 6-32 HEX, S/S	1
20	TM-47578	TERMINAL, ORANGE, 8 PIN	1
21	TM-47677	TERMINAL, 6 POS, GREEN	1
22	BA-47362	BOARD, RELAY	1
23	TM-47678	TERMINAL, 5 POS, GREEN	1

5035207DV1_2

Electrical Chassis, E, 208-240V DX 20-10—Panel Detail

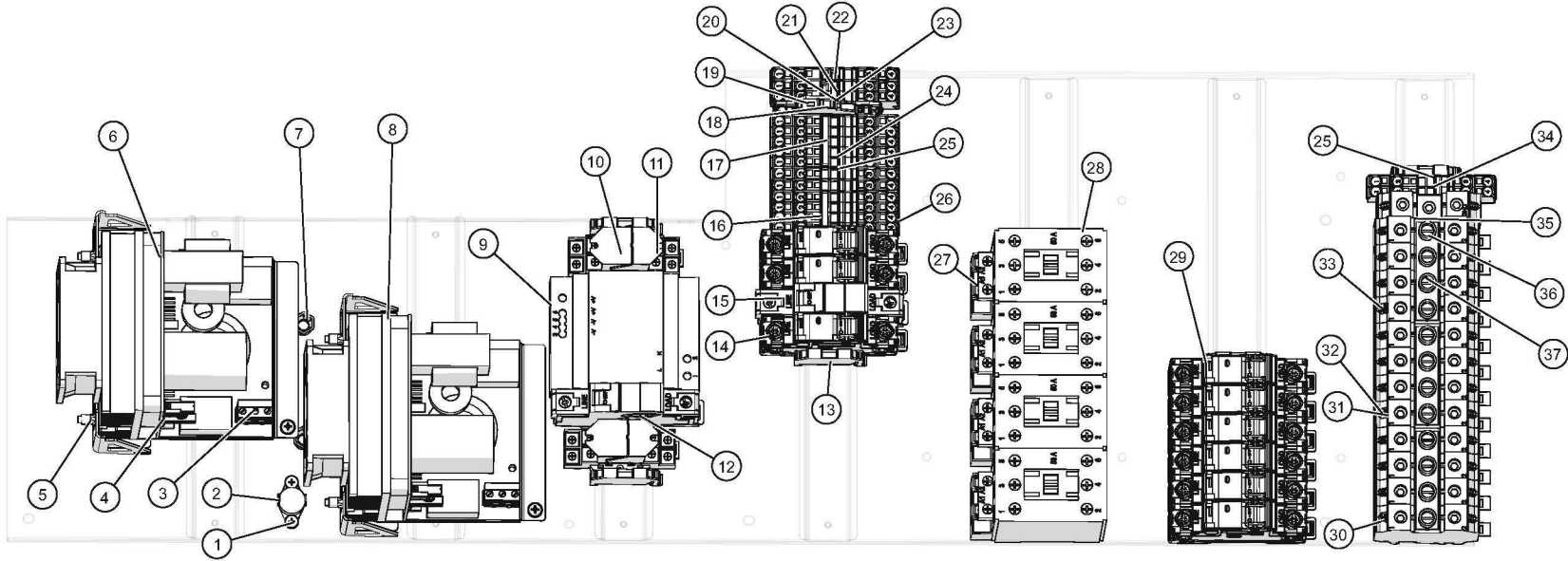

ID	Part No.	Description	Qty
1	SC-38693	SCREW, #8-18 X 1/2", PHIL, PAN	2
2	TT-36119	THERMOSTAT, BI-METAL, 100 DEG CLOSE	1
3	TM-34904	TERMINAL, 3-POLE GREEN, GMVSTBR	2
4	BA-39795	BOARD, VF MOTOR DRIVE,	2
5	NU-26866	NUT, HEX INSERT M4	8
6	SC-29261	SCREW,M4x0.7X50MM PAN	4
7	NU-28537	NUT, HEX INSERT M8	4
8	SC-37701	SCREW, M4 X 8MM SEMS	4
9	BA-46801	POWER SUPPLY, 12VDC, 100W	1
10	RL-33930	RELAY,12VDC, 15A,8 PINS	2
11	RL-34634	UNIVERSAL MOUNTING SOCKET	2
12	FU-47665	CIRCUIT BREAKER, 8A	1
13	TM-39606	TERMINAL, SCREWLESS END	6

ID	Part No.	Description	Qty
14	FU-46810	CIRCUIT BREAKER, 15A	3
15	FU-39058	CIRCUIT BREAKER, 20A	1
16	TM-39583	JUMPER, 4 POLE	1
17	TM-39582	JUMPER, 5 POLE	1
18	TM-39577	TERMINAL, FUSE HOLDER,	1
19	FU-36668	5X20MM, SLOW BLO, 5AMP, 250V	1
20	TM-39578	TERMINAL, END PLATE	1
21	TM-39585	JUMPER, 2 POLE	1
22	TM-47182	TERMINAL,4mm,BLACK,4-CONDUCTOR	1
23	TM-47638	TERMINAL,4mm,GRAY,4-CONDUCTOR	2
24	TM-39575	TERMINAL, 6mm, BLUE, SPRING	6
25	TM-39576	TERMINAL, END SECTION, SPRING	7
26	TM-39574	TERMINAL, 6mm, ORANGE, SPRING	5

ID	Part No.	Description	Qty
27	FI-33990	EMI FILTER	4
28	CN-3731	CONTACTOR, 50 AMP	4
29	FU-48045	CIRCUIT BREAKER,60A	6
30	TM-3790	TERMINALS, MARK, 1	1
31	TM-3788	TERMINALS, MARK, L	3
32	TM-3791	TERMINALS, MARK, 2	1
33	TM-3792	TERMINALS, MARK, 3	1
34	TM-39579	TERMINAL,GROUND, 6mm, SPRING	2
35	TM-47500	TERMINAL, GROUND, 16MM, 800V	1
36	TM-47406	TERMINAL, 16mm, 125A, 800V	12
37	TM-47409	CONNECTOR, CROSS, 4-POLE	3

5035207DV2_2

Electrical Chassis, E, 208-240V 3PH SX 20-10

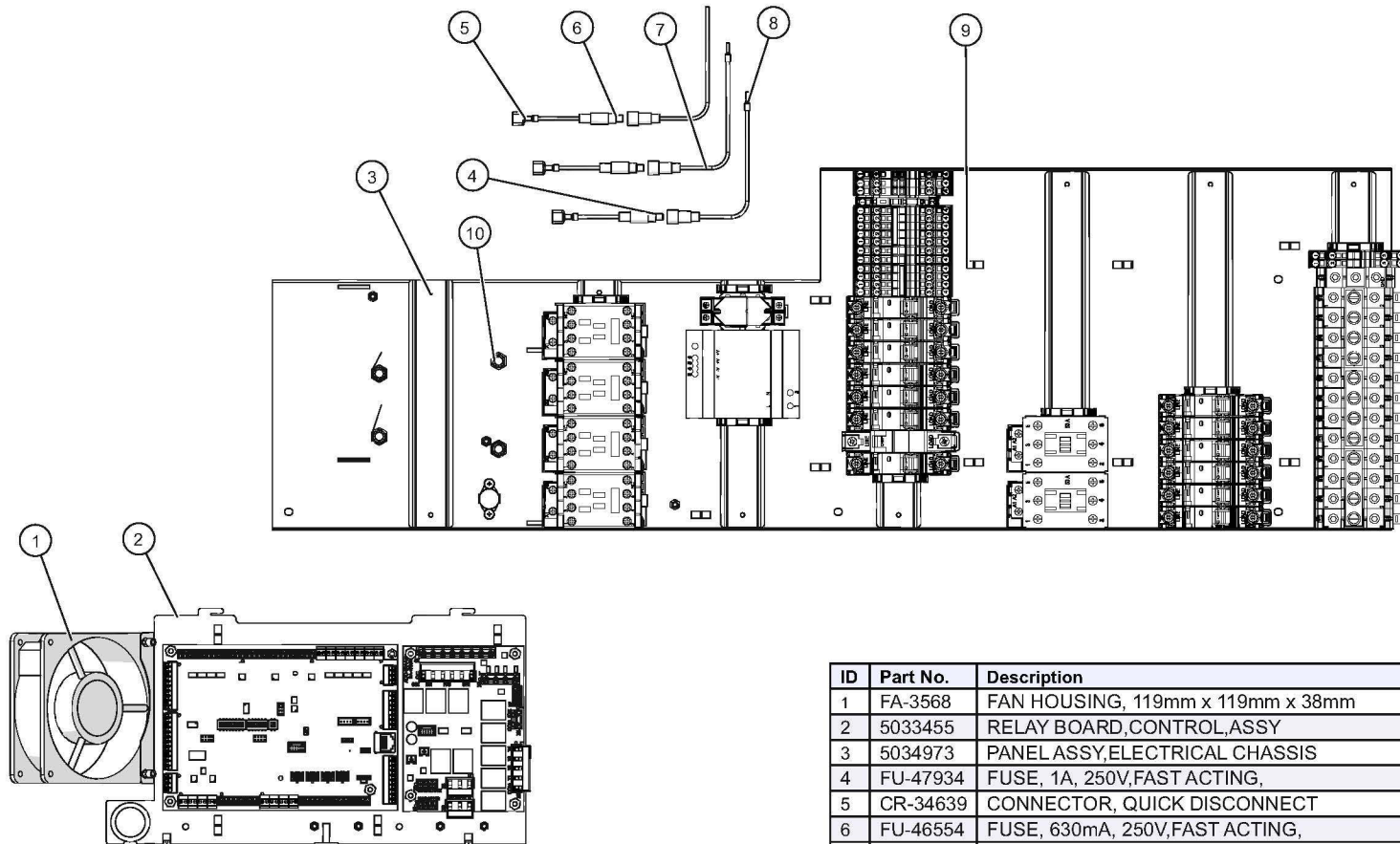

ID	Part No.	Description	Qty
1	FA-3568	FAN HOUSING, 119mm x 119mm x 38mm	1
2	5033455	RELAY BOARD, CONTROL, ASSY	1
3	5034973	PANEL ASSY, ELECTRICAL CHASSIS	1
4	FU-47934	FUSE, 1A, 250V, FAST ACTING,	2
5	CR-34639	CONNECTOR, QUICK DISCONNECT	3
6	FU-46554	FUSE, 630mA, 250V, FAST ACTING,	1
7	FU-36762	IN-LINE FUSE HOLDER, 5X20MM 150 SERIES	3
8	CR-36843	CONNECTOR, INSULATED FERRULE	2
9	CL-47555	PUSH IN WIRE RETAINER	13
10	NU-28537	NUT, HEX INSERT M8	4

5035281_1

Electrical Chassis, E, 208-240V 3PH SX 20-10—Relay Board Detail

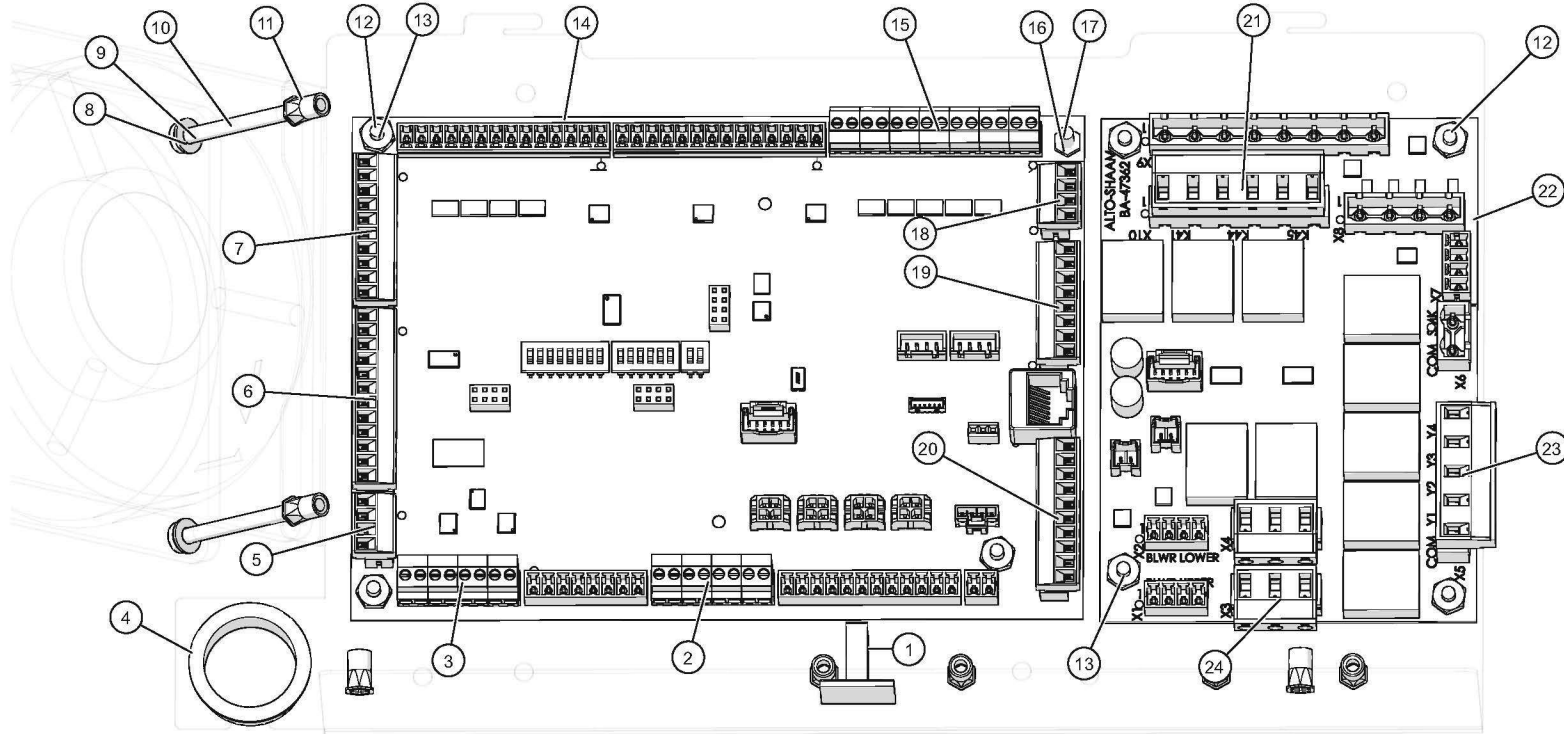

ID	Part No.	Description	Qty
1	CM-38423	ADHESIVE WIRE RETAINER	1
2	CR-46948	CONNECTOR, 8 POS, GREEN	1
3	CR-46946	CONNECTOR, 8 POS, BLACK	1
4	BU-3378	1 1/8" SNAP BUSHING	1
5	TM-47576	TERMINAL, WHITE, 4 PIN	1
6	TM-47580	TERMINAL, BLUE, 12 PIN	1
7	TM-47680	TERMINAL, BLACK, 10 PIN	1
8	WS-22300	WASHER, M4 SPLIT LOCK	2
9	WS-22294	WASHER, FLAT M4 18-8 S/S	2

ID	Part No.	Description	Qty
10	SC-29261	SCREW, M4x0.7X50MM PAN	2
11	NU-26866	NUT, HEX INSERT M4	8
12	NU-39735	NUT, HEX, 6-32, NYLON	7
14	BA-46624	COMBI MULTI COOK CONTROL	1
15	CR-46952	CONNECTOR, 14 POS, GREEN	1
16	SP-38839	SPACER, M4, 4 ID x 6 OD x 6MM LG	1
17	NU-2361	NUT, 6-32 HEX, S/S	1
18	TM-47577	TERMINAL, GREY, 4 PIN	1

ID	Part No.	Description	Qty
19	TM-47578	TERMINAL, ORANGE, 8 PIN	1
20	TM-47579	TERMINAL, BLUE, 10 PIN	1
21	TM-47677	TERMINAL, 6 POS, GREEN	1
22	BA-47362	BOARD, RELAY	1
23	TM-47678	TERMINAL, 5 POS, GREEN	1
24	TM-47674	TERMINAL, 3 POS, GREEN	2

5035281DV1_1

Electrical Chassis, E, 208-240V 3PH SX 20-10—Panel Detail

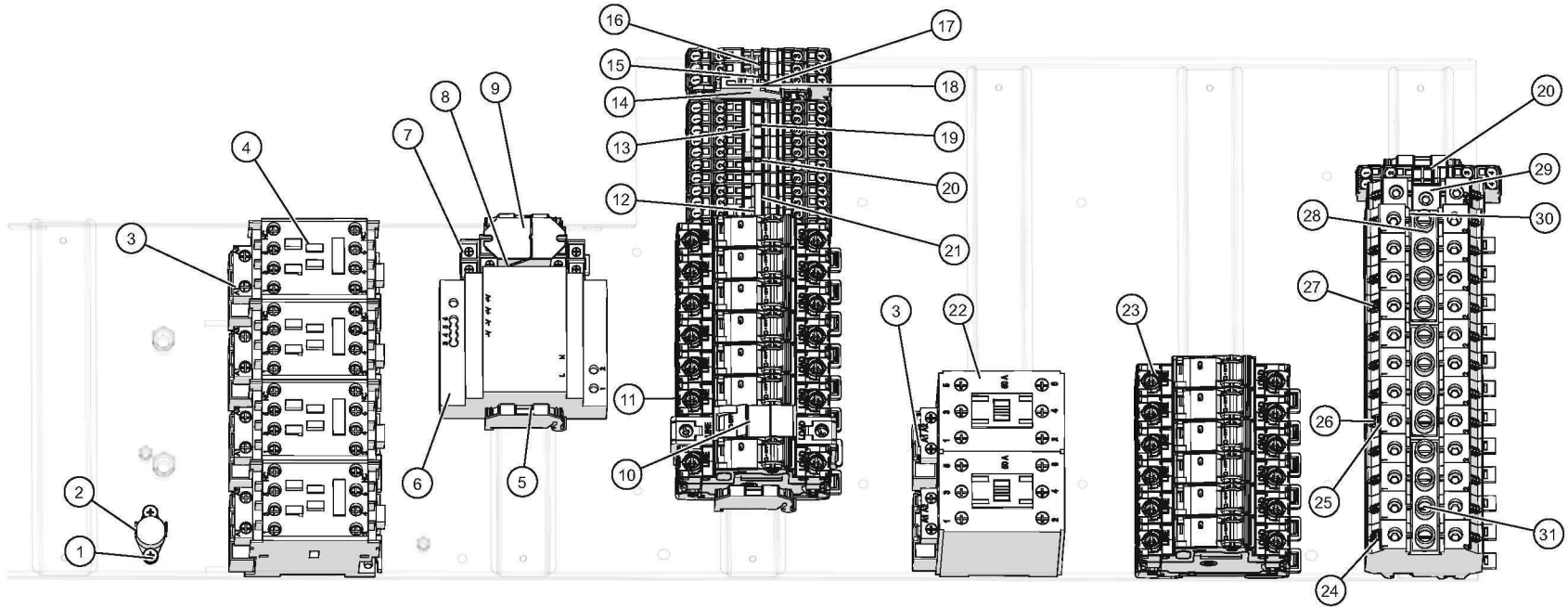

ID	Part No.	Description	Qty
1	SC-38693	SCREW, #8-18 X 1/2", PHIL, PAN	2
2	TT-36119	THERMOSTAT, BI-METAL,100 DEG CLOSE	1
3	FI-33990	EMI FILTER	6
4	CN-47697	CONTACTOR,240V,32A,SCREW	4
5	TM-39606	TERMINAL, SCREWLESS END	8
6	BA-46801	POWER SUPPLY, 12VDC, 100W	1
7	RL-34634	UNIVERSAL MOUNTING SOCKET	1
8	RL-37266	SPRING, HOLD DOWN,	1
9	RL-33930	RELAY,12VDC,15A,8 PINS	1
10	FU-39058	CIRCUIT BREAKER, 20A	1
11	FU-46810	CIRCUIT BREAKER, 15A	7

ID	Part No.	Description	Qty
12	TM-39583	JUMPER, 4 POLE	1
13	TM-39582	JUMPER, 5 POLE	1
14	TM-39577	TERMINAL, FUSE HOLDER,	1
15	TM-47638	TERMINAL,4mm,GRAY,4-CONDUCTOR	2
16	TM-47182	TERMINAL,4mm,BLACK,4-CONDUCTOR	1
17	TM-39578	TERMINAL, END PLATE	1
18	FU-36668	5X20MM, SLOW BLO, 5AMP, 250V	1
19	TM-39575	TERMINAL, 6mm, BLUE, SPRING	6
20	TM-39576	TERMINAL, END SECTION, SPRING	7
21	TM-39574	TERMINAL, 6mm, ORANGE, SPRING	5
22	CN-3731	CONTACTOR, 50 AMP	2

ID	Part No.	Description	Qty
23	FU-48045	CIRCUIT BREAKER,60A	6
24	TM-3790	TERMINALS, MARK, 1	1
25	TM-3788	TERMINALS, MARK, L	3
26	TM-3791	TERMINALS, MARK, 2	1
27	TM-3792	TERMINALS, MARK, 3	1
28	TM-47406	TERMINAL, 16mm, 125A, 800V	12
29	TM-39579	TERMINAL,GROUND, 6mm, SPRING	2
30	TM-47500	TERMINAL, GROUND, 16MM, 800V	1
31	TM-47409	CONNECTOR, CROSS, 4-POLE	3

5035281DV2_1

Heating Element Package, 230V

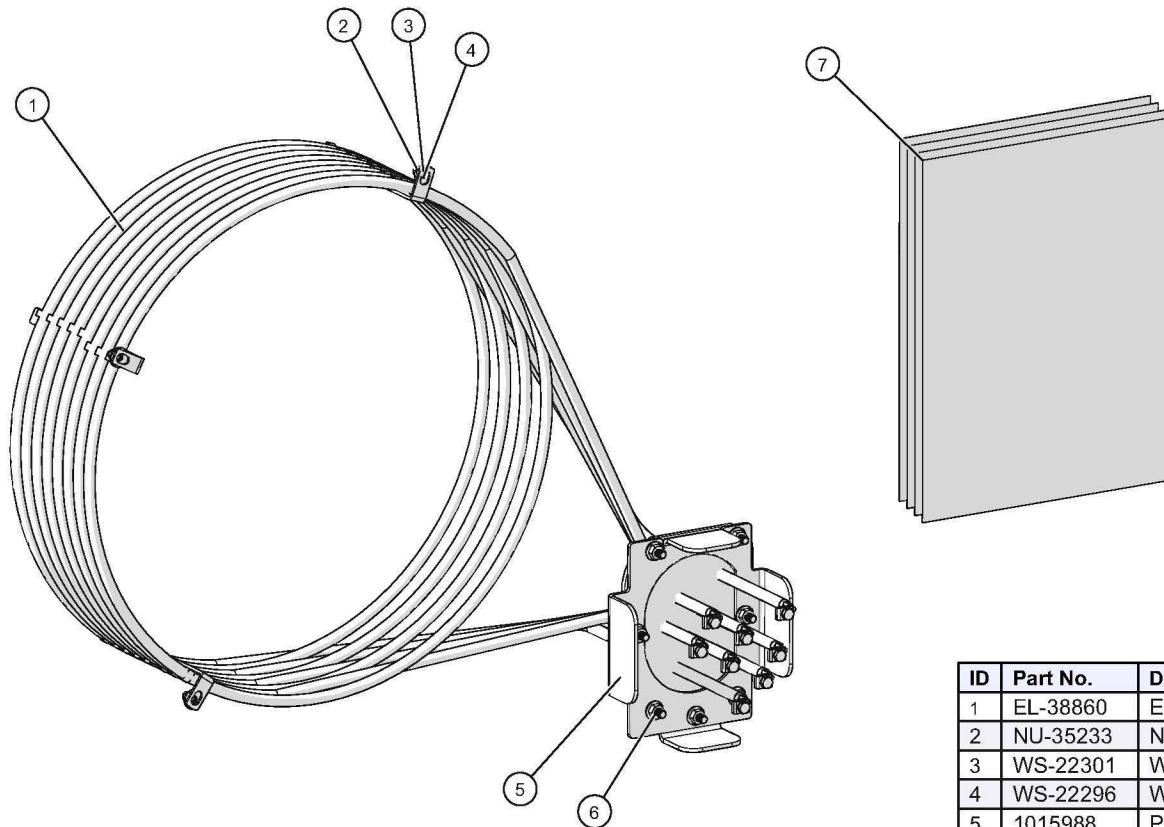

ID	Part No.	Description	Qty
1	EL-38860	ELEMENT, COILED TUBULAR,22.1KW	1
2	NU-35233	NUT, DOMED, M5	3
3	WS-22301	WASHER,M5 SPLIT LOCK,SS	3
4	WS-22296	WASHER, M5 X 15MM , 18-8SS	3
5	1015988	PLATE,STIFFENER,SMALL	1
6	NU-38844	NUT, M6 X 1, SERRATED FLANGE	7
7	SRV-20051	SERVICE DOC,REPLACE ELEMENTS	1

5016231_29

Preheat Strip Assembly

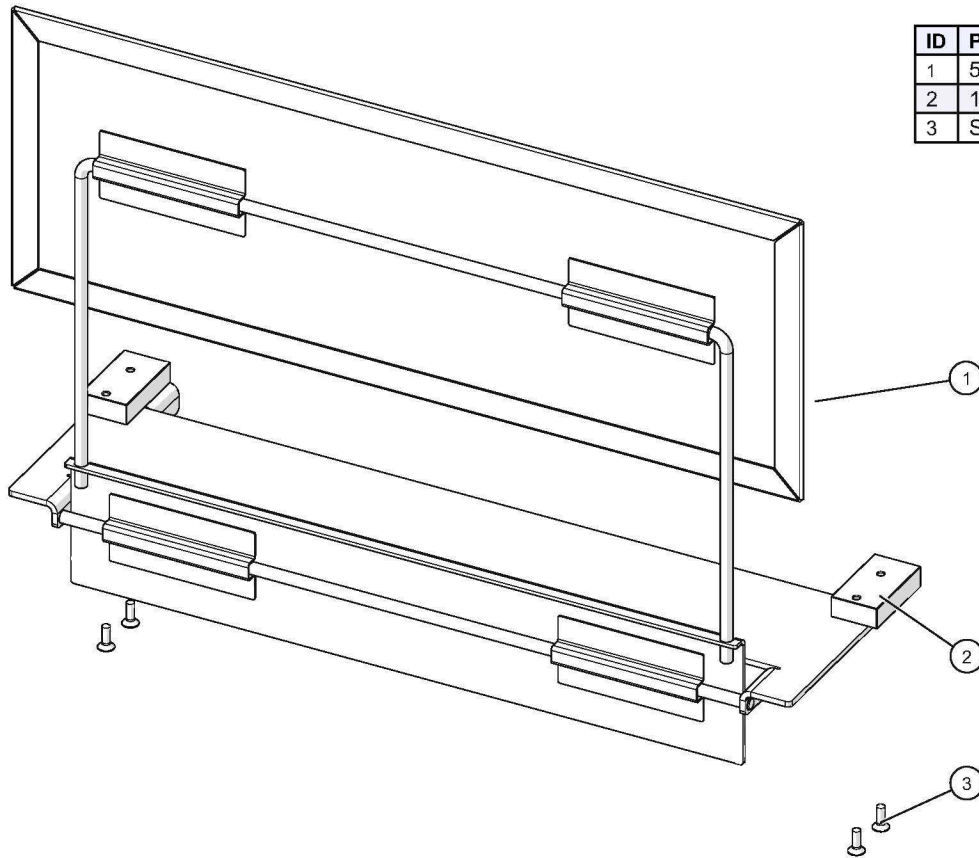

ID	Part No.	Description	Qty
1	5022111	STRIP, PREHEAT, WELD/SPOT ASSY	1
2	1020215	SLIDER, PRE HEAT STRIP,ROLL IN	2
3	SC-23141	SCREW,M4x0.7X14MM FLAT	4

5031884_0

Smoker Box Package, 120V

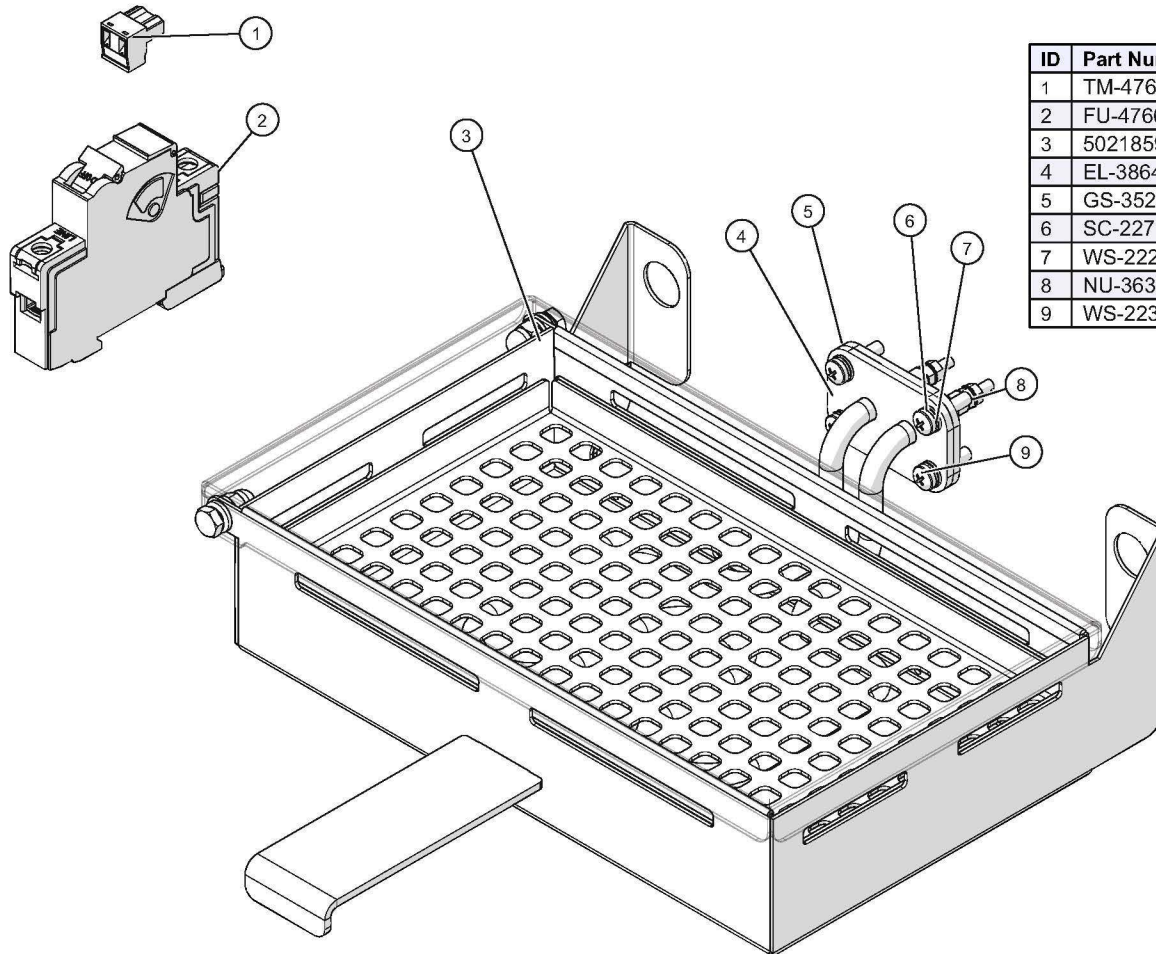

ID	Part Number	Description	Qty.
1	TM-47675	TERMINAL, 2 POS, GREEN	1
2	FU-47665	CIRCUIT BREAKER, 8A	1
3	5021859	COMBI SMOKER BOX ASSEMBLY	1
4	EL-38642	ELEMENT, TUBULAR, SMOKER, 120V	1
5	GS-35229	GASKET, SMOKER BOX	1
6	SC-22779	SCREW, M5x0.8X20MM PAN	4
7	WS-22295	WASHER, FLAT M5 S/S	4
8	NU-36319	NUT, M4, KEPS, ZINC PLATED	4
9	WS-22301	WASHER, M5 SPLIT LOCK S/S 18-8	4

5033596_1

Smoker Box Package, 208V-380V

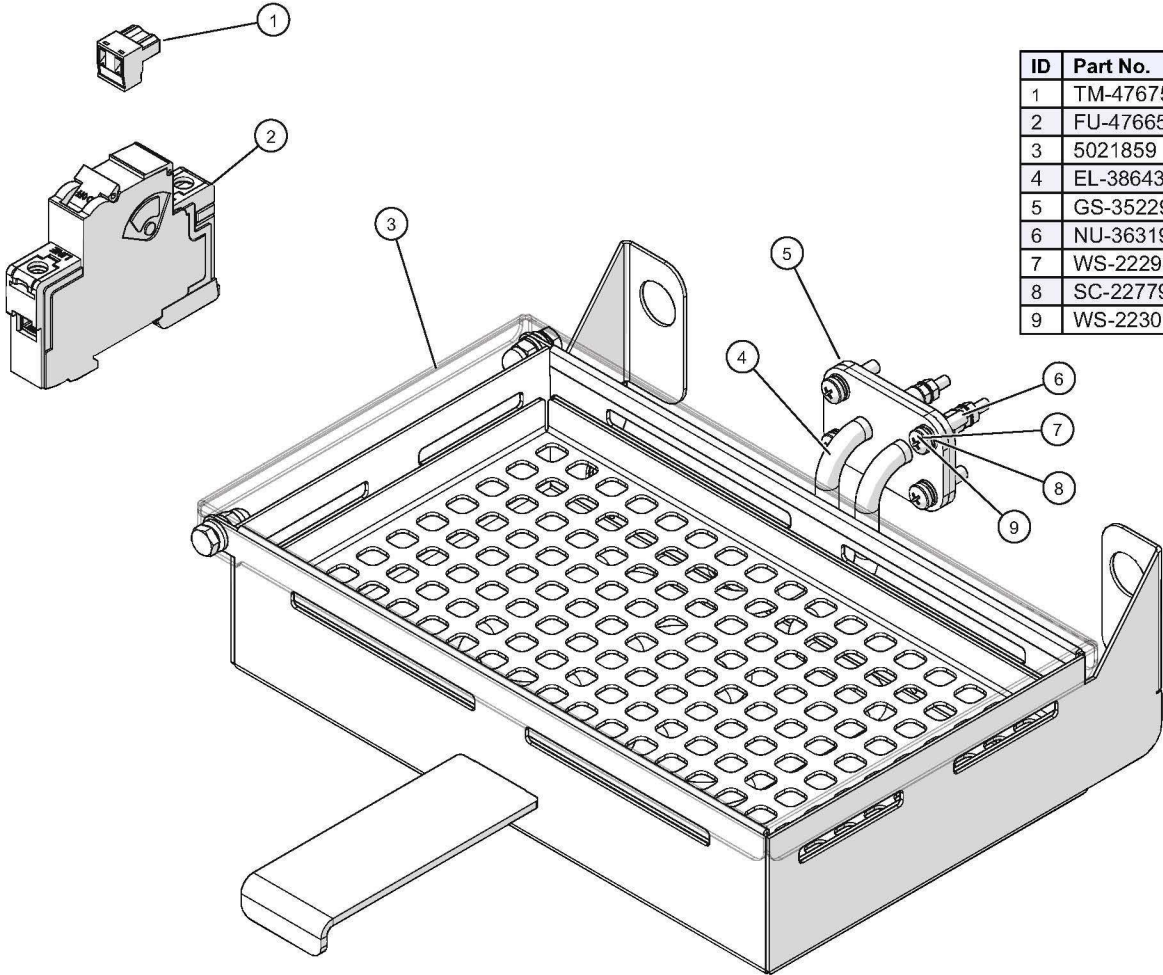

ID	Part No.	Description	Qty
1	TM-47675	TERMINAL, 2 POS, GREEN	1
2	FU-47665	CIRCUIT BREAKER, 8A	1
3	5021859	COMBI SMOKER BOX ASSEMBLY	1
4	EL-38643	ELEMENT, TUBULAR, SMOKER, 208V	1
5	GS-35229	GASKET, SMOKER BOX	1
6	NU-36319	NUT, M4, KEPS, ZINC PLATED	4
7	WS-22295	WASHER, FLAT M5 S/S	4
8	SC-22779	SCREW, M5x0.8X20MM PAN	4
9	WS-22301	WASHER, M5 SPLIT LOCK S/S 18-8	4

5033599_1

Non-Smoker Box Assembly

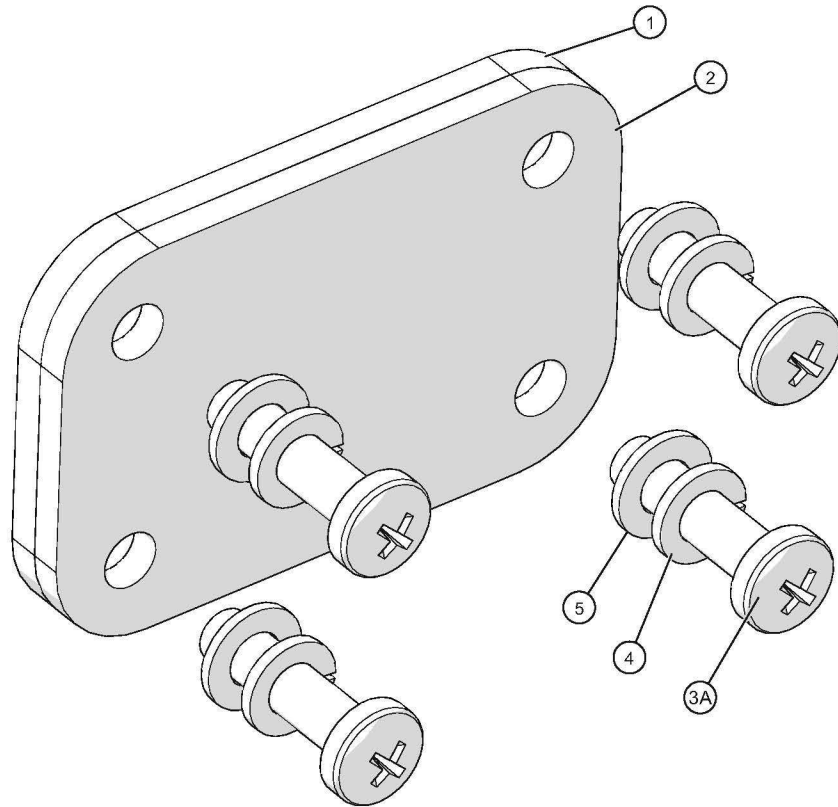

ID	Part No.	Description	Qty
1	GS-35229	GASKET, SMOKER BOX	1
2	1037010	PLATE, SMOKER COVER	1
3A	SC-22779	SCREW, M5x0.8X20MM PAN	4
3B	SC-28457	SCREW, M5x0.8x16MM PAN SPNR (PRISON)	4
4	WS-22301	WASHER, M5 SPLIT LOCK S/S 18-8	4
5	WS-22295	WASHER, FLAT M5 S/S	4

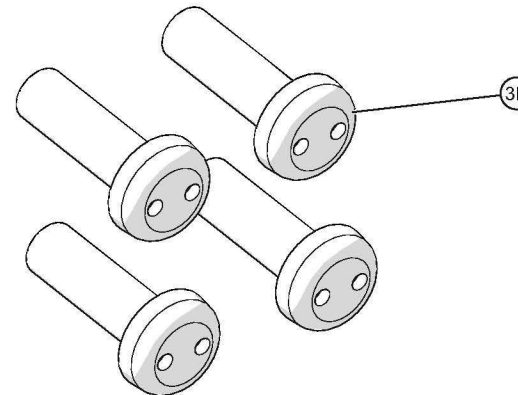

5033602_0

Probe Package, Detachable, 20-10 and 20-20

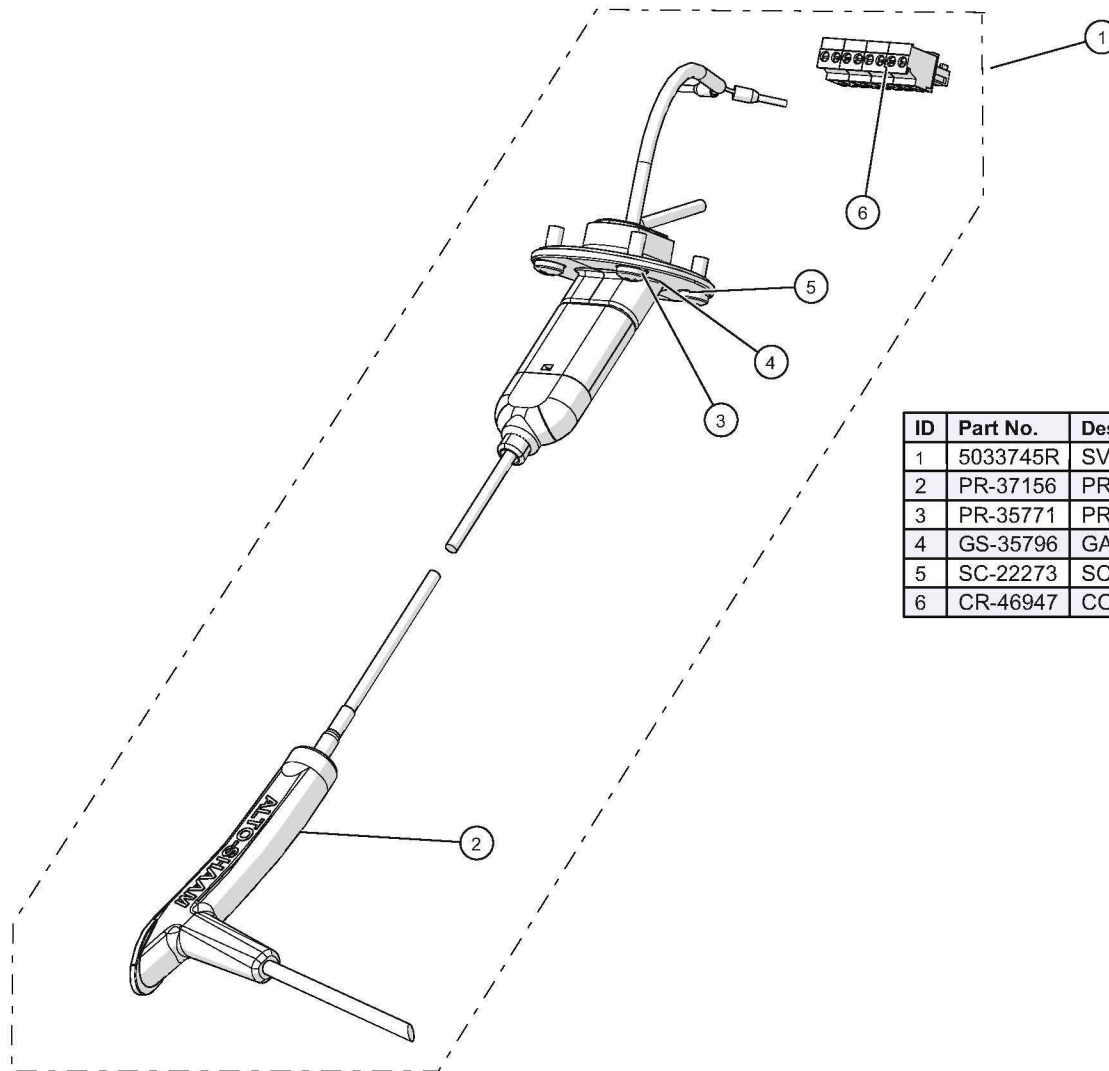

ID	Part No.	Description	Qty
1	5033745R	SVC KIT, PROBE PKG, DETACHABLE, 20-10 & 20-20	1
2	PR-37156	PROBE, QUICK RELEASE, 1600mm	1
3	PR-35771	PROBE, RECEPTACLE, 1300mm	1
4	GS-35796	GASKET, CAVITY PROBE	1
5	SC-22273	SCREW, M4x0.7X10MM PAN	4
6	CR-46947	CONNECTOR, 8 POS, BLUE	1

5033745_12

Probe Plug Package

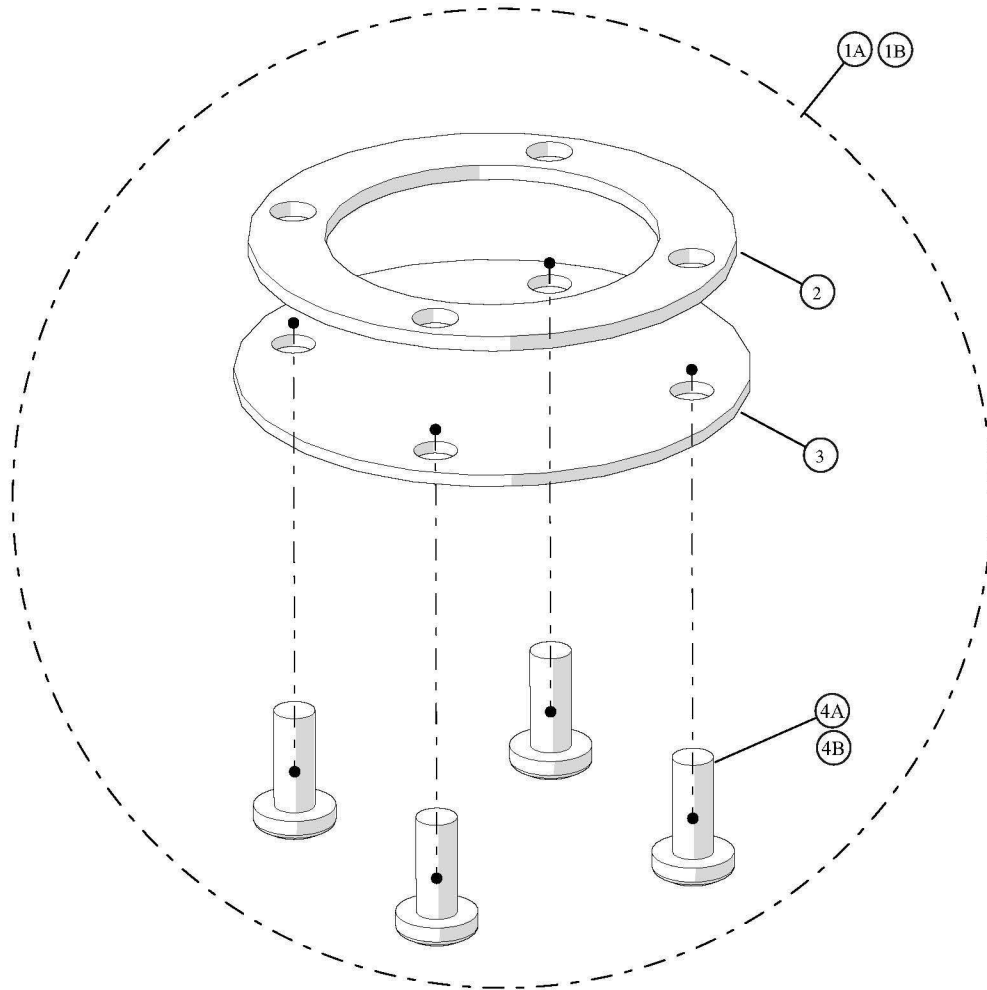

ID	Part No.	Description	Qty
1A	5016130R	PROBE PLUG PACKAGE	1
1B	5035703R	PROBE PLUG PACKAGE (PRISON)	1
2	GS-35796	GASKET, CAVITY PROBE	1
3	1014297	FOOD PROBE COVER PLATE, COMBI	1
4A	SC-22273	SCREW,M4x0.7X10MM PAN	4
4B	SC-23997	SCREW,M4x0.7X10MM PAN SPNR SST (PRISON)	4

5016130_12

Turbo Option Kits (all models)

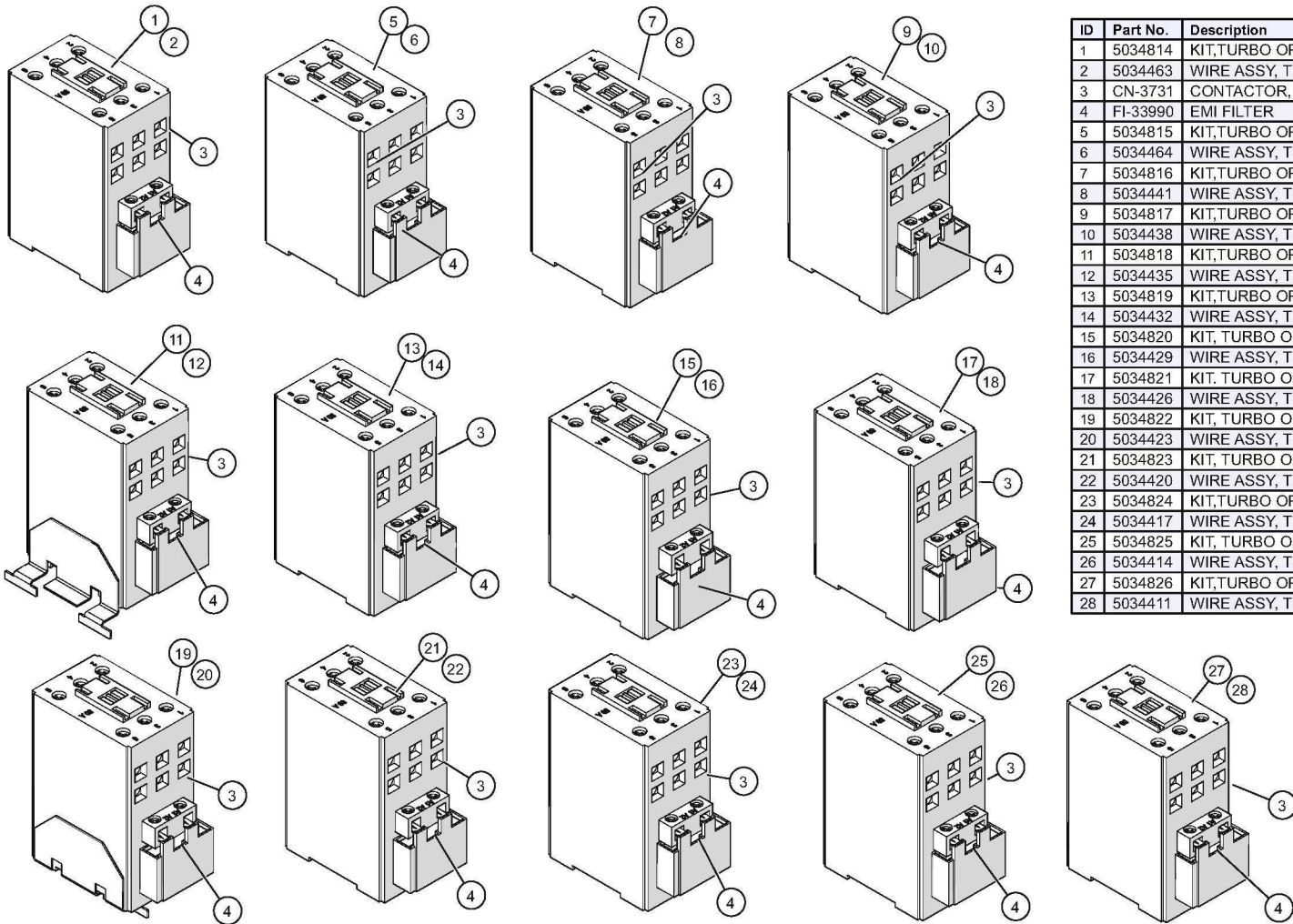

ID	Part No.	Description
1	5034814	KIT,TURBO OPTION,208V 1PH,6-10,7-20,10-10
2	5034463	WIRE ASSY, TURBO, 208V 1PH, 6-10
3	CN-3731	CONTACTOR, 50 AMP
4	FI-33990	EMI FILTER
5	5034815	KIT,TURBO OPTION,208V 3PH,6-10,7-20,10-10
6	5034464	WIRE ASSY, TURBO, 208V 3PH, 6-10 7-10 7-20
7	5034816	KIT,TURBO OPTION ,20-20,440V 3PH
8	5034441	WIRE ASSY, TURBO, 440V 3PH, 20-20
9	5034817	KIT,TURBO OPTION, 20-10,440V 3PH
10	5034438	WIRE ASSY, TURBO, 440V 3PH, 20-10
11	5034818	KIT,TURBO OPTION,10-20,440V 3PH
12	5034435	WIRE ASSY, TURBO, 440V 3PH, 10-20
13	5034819	KIT,TURBO OPTION,6-10,7-20,10-10 440V
14	5034432	WIRE ASSY, TURBO, 440V 3PH, 6-10 7-20 10-10
15	5034820	KIT, TURBO OPTION,20-20, 380V 3PH
16	5034429	WIRE ASSY, TURBO, 380V 3PH, 20-20
17	5034821	KIT, TURBO OPTION, 20-10, 380V 3PH
18	5034426	WIRE ASSY, TURBO, 380V 3PH, 20-10
19	5034822	KIT, TURBO OPTION,10-20, 380V 3PH
20	5034423	WIRE ASSY, TURBO, 380V 3PH, 10-20
21	5034823	KIT, TURBO OPTION,6-10,7-20,10-10 380V
22	5034420	WIRE ASSY, TURBO, 380V 3PH, 6-10 10-10 7-20
23	5034824	KIT,TURBO OPTION,20-20,208V 3PH
24	5034417	WIRE ASSY, TURBO, 208V 3PH 20-20
25	5034825	KIT, TURBO OPTION, 20-10, 208V 3PH
26	5034414	WIRE ASSY, TURBO, 280V 3PH, 20-10
27	5034826	KIT,TURBO OPTION,10-20,208V 3PH
28	5034411	WIRE ASSY, TURBO, 208V 3PH, 10-20

NOTE: Wire assemblies are not shown.

Motor Assembly, Classic 110-130V

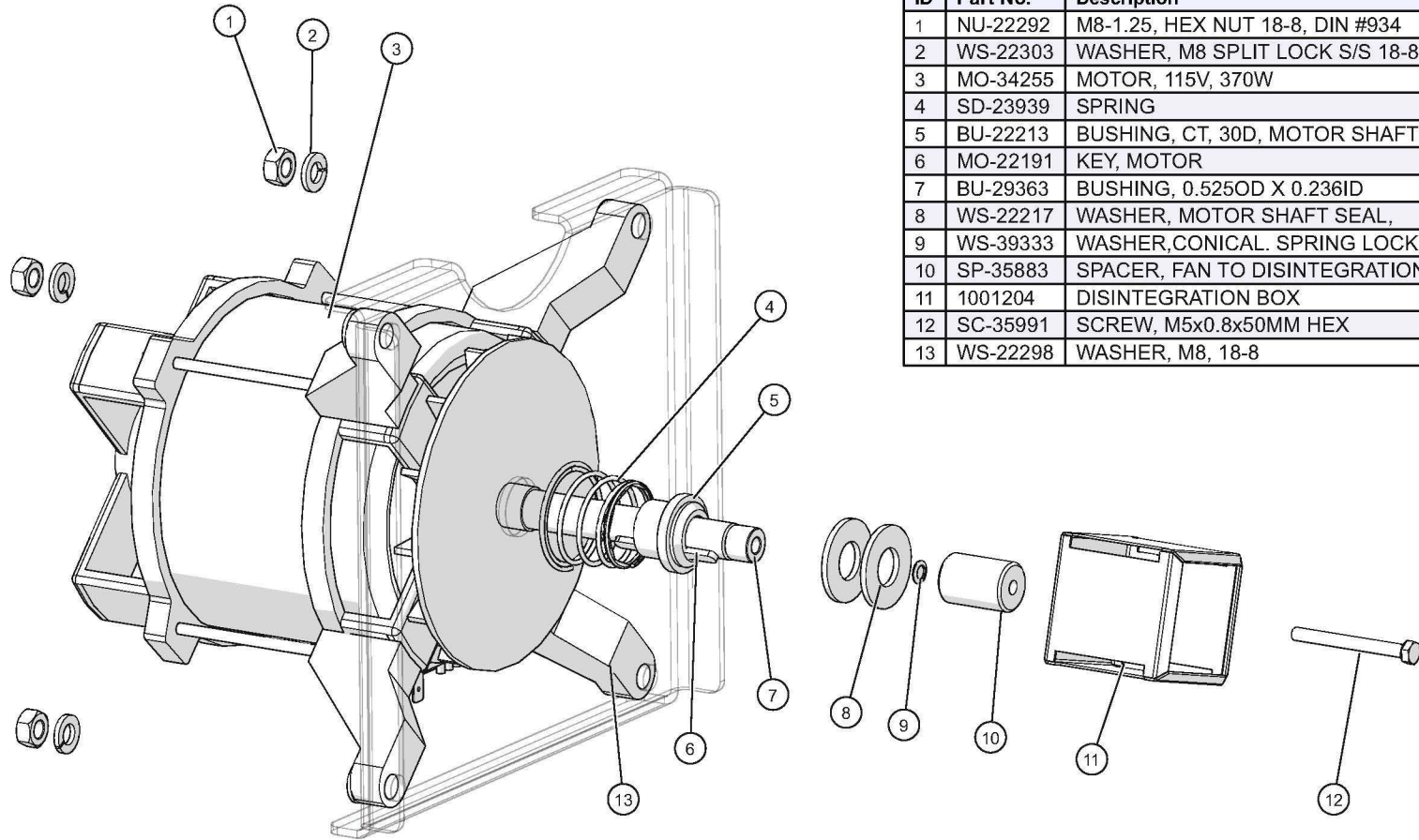

ID	Part No.	Description	Qty
1	NU-22292	M8-1.25, HEX NUT 18-8, DIN #934	4
2	WS-22303	WASHER, M8 SPLIT LOCK S/S 18-8	4
3	MO-34255	MOTOR, 115V, 370W	1
4	SD-23939	SPRING	1
5	BU-22213	BUSHING, CT, 30D, MOTOR SHAFT	1
6	MO-22191	KEY, MOTOR	1
7	BU-29363	BUSHING, 0.525OD X 0.236ID	1
8	WS-22217	WASHER, MOTOR SHAFT SEAL,	2
9	WS-39333	WASHER, CONICAL. SPRING LOCK,	1
10	SP-35883	SPACER, FAN TO DISINTEGRATION BOX	1
11	1001204	DISINTEGRATION BOX	1
12	SC-35991	SCREW, M5x0.8x50MM HEX	1
13	WS-22298	WASHER, M8, 18-8	4

5015474_9

Motor Assembly, Classic 200-240V

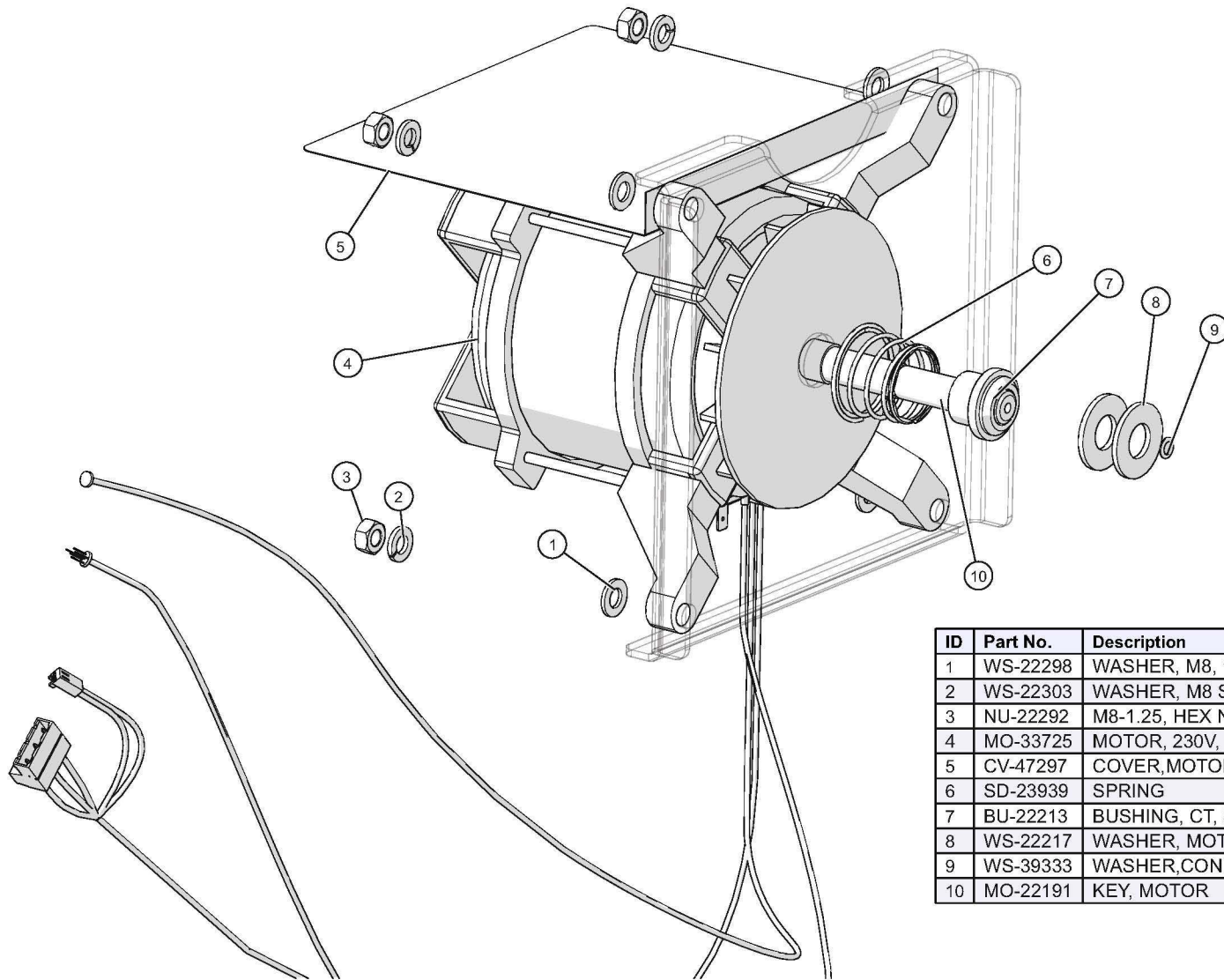

ID	Part No.	Description	Qty
1	WS-22298	WASHER, M8, 18-8	4
2	WS-22303	WASHER, M8 SPLIT LOCK S/S 18-8	4
3	NU-22292	M8-1.25, HEX NUT 18-8, DIN #934	4
4	MO-33725	MOTOR, 230V, 400W	1
5	CV-47297	COVER, MOTOR, CONVECTION, SHIELD	1
6	SD-23939	SPRING	1
7	BU-22213	BUSHING, CT, 30D, MOTOR SHAFT	1
8	WS-22217	WASHER, MOTOR SHAFT SEAL,	2
9	WS-39333	WASHER, CONICAL. SPRING LOCK,	1
10	MO-22191	KEY, MOTOR	1

5015391_9

Motor Assembly, Pro

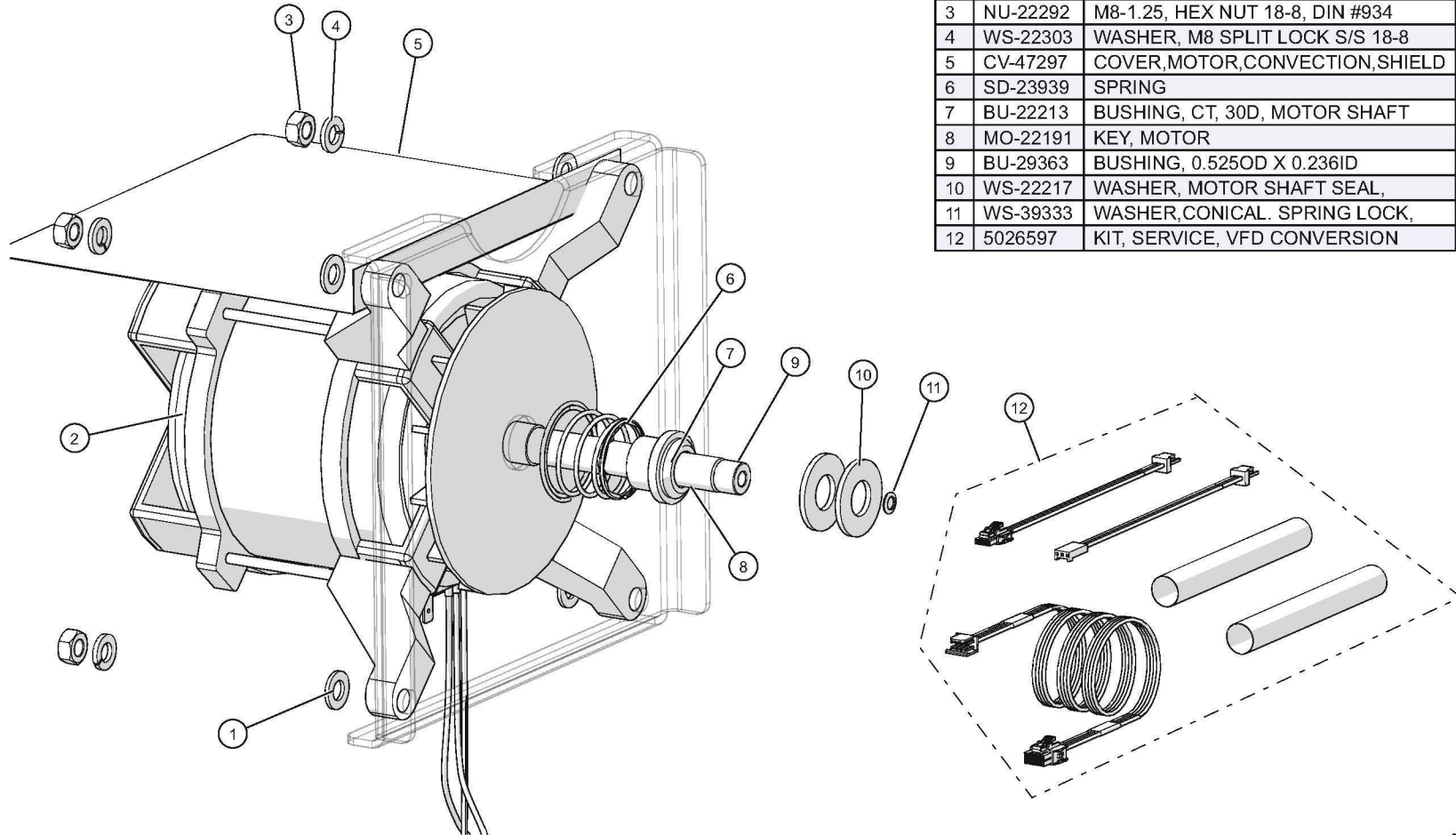

ID	Part No.	Description	Qty
1	WS-22298	WASHER, M8, 18-8	4
2	MO-39797	MOTOR,0.68 KW, DRIVE REVERSE	1
3	NU-22292	M8-1.25, HEX NUT 18-8, DIN #934	4
4	WS-22303	WASHER, M8 SPLIT LOCK S/S 18-8	4
5	CV-47297	COVER,MOTOR,CONVECTION,SHIELD	1
6	SD-23939	SPRING	1
7	BU-22213	BUSHING, CT, 30D, MOTOR SHAFT	1
8	MO-22191	KEY, MOTOR	1
9	BU-29363	BUSHING, 0.525OD X 0.236ID	1
10	WS-22217	WASHER, MOTOR SHAFT SEAL,	2
11	WS-39333	WASHER,CONICAL. SPRING LOCK,	1
12	5026597	KIT, SERVICE, VFD CONVERSION	1

5014833_9

Solenoids and Fans, 120V, 20-10 and 20-20

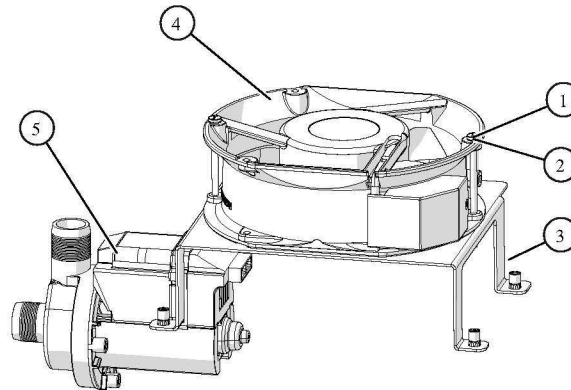
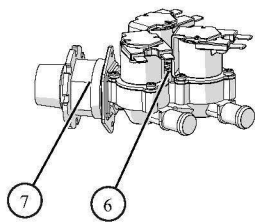
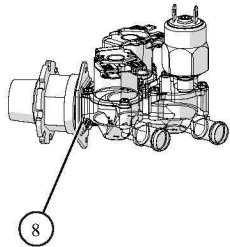
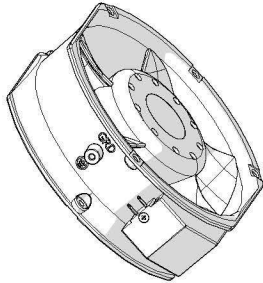

ID	Part No.	Description	Qty
1	WS-22300	WASHER, SPLIT LOCK	2
2	SC-36699	SCREW,M4x0.7X70MM PAN	2
3	5021589	SUPPORT BRACKET,FAN	1
4	FA-36689	FAN, AXIAL, 115V, 172X150X55MM	2
5	MO-35262	PUMP, WASH SYSTEM, 110V	1
6	VA-38647	VALVE, SOLENOID, TRIPLE PORT	1
7	5024963	FITTING, G 3/4 BSP BY 3/4 NPT	2
8	5036008	VALVE,SOLENOID,3PORT,120V	1

5034839_2

Solenoids and Fans, 208-440V, 20-10 and 20-20

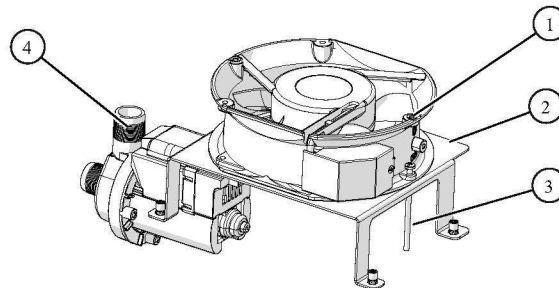
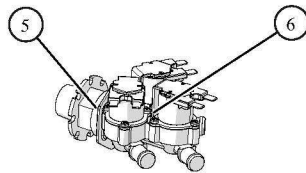
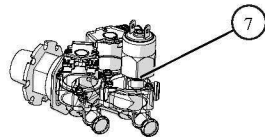
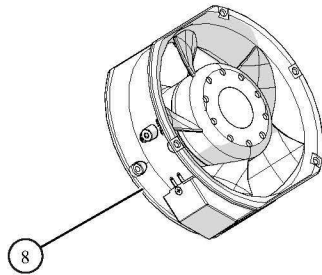

ID	Part No.	Description	Qty
1	WS-22300	WASHER, SPLIT LOCK	2
2	5021589	SUPPORT BRACKET,FAN	1
3	SC-36699	SCREW,M4x0.7X70MM PAN	2
4	MO-35160	PUMP, WASH SYSTEM, 220V	1
5	5024963	FITTING, G 3/4 BSP BY 3/4 NPT	2
6	VA-38648	VALVE, SOLENOID, TRIPLE PORT	1
7	5036009	VALVE,SOLENOID,3PORT,240V	1
8	FA-36690	FAN, AXIAL, 230V, 172X150X55MM	2

5034534_3

Pan Trolley, 20-10

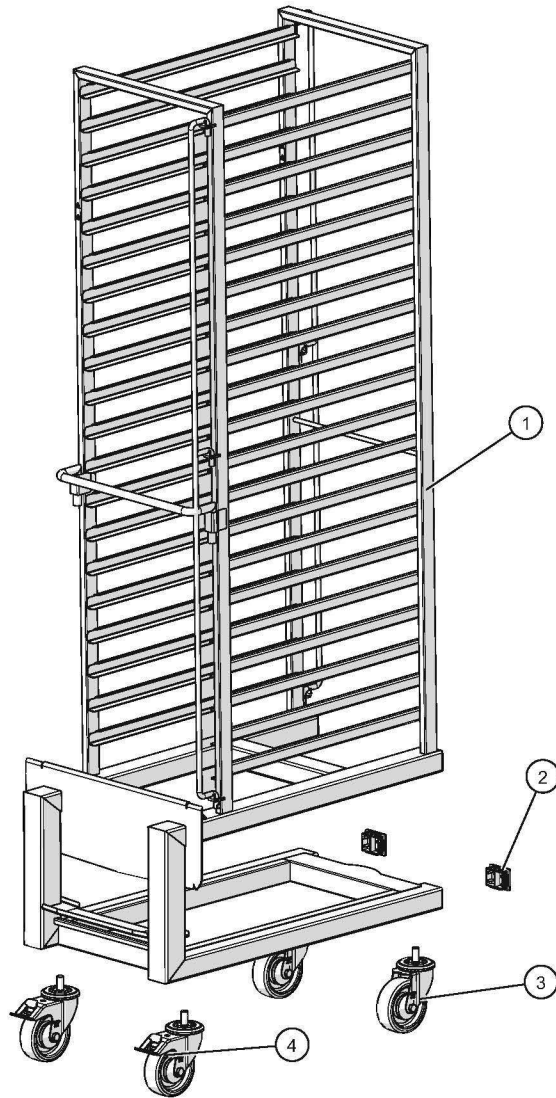

ID	Part No.	Description	Qty
1	5026388	TROLLEY, PAN, 20-10	1
2	CP-39762	CAP, TUBE END, LOWER, 40X50mm,	2
3	CS-39503	CASTER, SWIVEL, 100MM, NO BRAKE	2
4	CS-39504	CASTER, SWIVEL, 100MM, WITH BRAKE	2

5026833_3



ALTO-SHAAM.

Menomonee Falls, WI U.S.A.

Phone 800 -558-8744 | +1-262-251-3800 | alto-shaam.com

ASIA

Shanghai, China
Phone +86-21-6173-0336

AUSTRALIA

Brisbane, Queensland
Phone 800-558-8744

CANADA

Concord, Ontario Canada
Toll Free Phone 866-577-4484
Phone +1-905-660-6781

FRANCE

Aix en Provence, France
Phone +33(0)4-88-78-21-73

GMBH

Bochum, Germany
Phone +49 (0)234 298798-0

ITALY

Padua, Italy
Phone +39 3476073504

INDIA

Pune, India
Phone +91 9657516999

MEXICO

Phone +52 1 477-717-3108

MIDDLE EAST & AFRICA

Dubai, UAE
Phone +971-4-321-9712

CENTRAL & SOUTH AMERICA

Miami, FL USA
Phone +1 954-655-5727