



## ***Natural Gas Rotisserie***

Model CE-CN-KJ-5

Item 47495

## ***Instruction Manual***



*Revised - 08/01/2024*

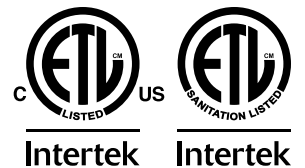

Toll Free: 1-800-465-0234  
Fax: 905-607-0234  
Email: [service@omcan.com](mailto:service@omcan.com)  
[www.omcan.com](http://www.omcan.com)



# ***Table of Contents***

Model CE-CN-KJ-5

---

<b>Section</b>	<b>Page</b>
General Information -----	3 - 4
Safety and Warranty -----	4 - 6
Technical Specifications -----	6
Installation -----	6 - 8
Operation -----	8 - 9
Maintenance -----	9 - 10
Troubleshooting -----	10 - 11
Parts Breakdown -----	12 - 13
Electrical Schematics -----	14
Warranty Registration -----	15



## **General Information**

---

**Omcan Manufacturing and Distributing Company Inc., Food Machinery of America, Inc. dba Omcan and Omcan Inc. are not responsible for any harm or injury caused due to any person's improper or negligent use of this equipment. The product shall only be operated by someone over the age of 18, of sound mind, and not under the influence of any drugs or alcohol, who has been trained in the correct operation of this machine, and is wearing authorized, proper safety clothing. Any modification to the machine voids any warranty, and may cause harm to individuals using the machine or in the vicinity of the machine while in operation.**

### **CHECK PACKAGE UPON ARRIVAL**

Upon receipt of an Omcan shipment please inspect for external damage. If no damage is evident on the external packaging, open carton to ensure all ordered items are within the box, and there is no concealed damage to the machine. If the package has suffered rough handling, bumps or damage (visible or concealed), please note it on the bill of lading before accepting the delivery and contact Omcan within 24 hours, so we may initiate a claim with the carrier. A detailed report on the extent of the damage caused to the machine must be filled out within three days, from the delivery date shown in the shipping documents. Omcan has no recourse for damaged products that were shipped collect or third party.

**Before operating any equipment, always read and familiarize yourself with all operation and safety instructions.**

**Omcan would like to thank you for purchasing this machine. It's of the utmost importance to save these instructions for future reference. Also save the original box and packaging for shipping the equipment if servicing or returning of the machine is required.**

---

**Omcan Fabrication et distribution Compagnie Limité et Food Machinery d'Amérique, dba Omcan et Omcan Inc. ne sont pas responsables de tout dommage ou blessure causé du fait que toute personne ait utilisé cet équipement de façon irrégulière. Le produit ne doit être exploité que par quelqu'un de plus de 18 ans, sain d'esprit, et pas sous l'influence d'une drogue ou d'alcool, qui a été formé pour utiliser cette machine correctement, et est vêtu de vêtements de sécurité appropriés. Toute modification de la machine annule toute garantie, et peut causer un préjudice à des personnes utilisant la machine ou des personnes à proximité de la machine pendant son fonctionnement.**

### **VÉRIFIEZ LE COLIS DÈS RÉCEPTION**

Dès réception d'une expédition d'Omcan veuillez inspecter pour dommages externes. Si aucun dommage n'est visible sur l'emballage externe, ouvrez le carton afin de s'assurer que tous les éléments commandés sont dans la boîte, et il n'y a aucun dommage dissimulé à la machine. Si le colis n'a subi aucune mauvaises manipulations, de bosses ou de dommages (visible ou cachée), notez-le sur le bond de livraison avant d'accepter la livraison et contactez Omcan dans les 24 heures qui suivent, pour que nous puissions engager une réclamation auprès du transporteur. Un rapport détaillé sur l'étendue des dommages causés à la machine doit être rempli dans un délai de trois jours, à compter de la date de livraison indiquée dans les documents d'expédition. Omcan n'a aucun droit de recours pour les produits endommagés qui ont été expédiés ou cueillis par un tiers transporteur.

**Avant d'utiliser n'importe quel équipement, toujours lire et vous familiariser avec toutes les opérations et les**

## ***General Information***

---

consignes de sécurité.

Omcan voudrais vous remercier d'avoir choisi cette machine. Il est primordial de conserver ces instructions pour une référence ultérieure. Également conservez la boîte originale et l'emballage pour l'expédition de l'équipement si l'entretien ou le retour de la machine est nécessaire.

Omcan Empresa De Fabricacion Y Distribucion Inc. Y Maquinaria De Alimentos De America, Inc. dba Omcan y Omcan Inc. no son responsables de ningun daño o perjuicio causado por cualquier persona inadecuada o el uso descuidado de este equipo. El producto solo podra ser operado por una persona mayor de 18 años, en su sano juicio y no bajo alguna influencia de droga o alcohol, y que este ha sido entrenado en el correcto funcionamiento de esta máquina, y ésta usando ropa apropiada y autorizada. Cualquier modificación a la máquina anula la garantía y puede causar daños a las personas usando la máquina mientras esta en el funcionamiento.

### **REVISE EL PAQUETE A SU LLEGADA**

Tras la recepcion de un envio Omcan favor inspeccionar daños externos. Si no hay daños evidentes en el empaque exterior, Habra el carton para asegurarse que todos los articulos solicitados estén dentro de la caja y no encuentre daños ocultos en la máquina. Si el paquete ha sufrido un manejo de poco cuidado, golpes o daños (visible o oculto) por favor anote en la factura antes de aceptar la entrega y contacte Omcan dentro de las 24 horas, de modo que podamos iniciar una reclamación con la compañía. Un informe detallado sobre los daños causados a la máquina debe ser llenado en el plazo de tres días, desde la fecha de entrega que se muestra en los documentos de envío. Omcan no tiene ningun recurso por productos dañados que se enviaron a recoger por terceros.

**Antes de utilizar cualquier equipo, siempre lea y familiarizarse con todas las instrucciones de funcionamiento y seguridad.**

Omcan le gustaría darle las gracias por la compra de esta máquina. Es de la mayor importancia para salvar estas instrucciones para futuras consultas. Además, guarda la caja original y el embalaje para el envío del equipo si servicio técnico o devolución de la máquina que se requiere.

## ***Safety and Warranty***

---

**IMPORTANT: ONLY A CERTIFIED GAS TECHNICIAN MAY PERFORM INSTALLATION OF THIS UNIT.**

This manual contains important information regarding your purchased equipment. Please read the manual thoroughly prior to equipment set-up, operation and maintenance. Failure to comply with regular maintenance guidelines outlined in this manual may void the warranty. Please keep it for future reference after installation and do not throw it away! This is a universal installation and operation instruction book



# Safety and Warranty

---

which would apply to different models. PLEASE READ!!!

## FOR YOUR SAFETY

- DO NOT STORE OR USE GASOLINE OR OTHER FLAMMABLE VAPORS OR LIQUIDS IN THE VICINITY OF THIS OR ANY OTHER EQUIPMENT.

## WARNING

- IMPROPER INSTALLATION, ADJUSTMENT, ALTERATION, SERVICE OR MAINTENANCE CAN CAUSE PROPERTY DAMAGE, INJURY OR DEATH.
- READ THE INSTALLATION AND MAINTENANCE INSTRUCTIONS THOROUGHLY BEFORE INSTALLING OR SERVICING THIS EQUIPMENT.
- Electrical grounding instructions: This appliance is equipped with a three-prong (grounding) plug for your protection against shock hazard and should be plugged directly into a properly grounded three-prong receptacle. Do not cut or remove the grounding prong from this plug.
- Wiring diagrams are located in the control compartment area of the rotisseries.
- Have the equipment installed by a qualified installer in accordance with all federal, state and local codes.
- This equipment is for use in non-combustible locations only.
- Do not obstruct the flow of combustion and ventilation air.
- Do not spray controls or the outside of the equipment with liquids or cleaning agents.
- Allow for hot parts to cool before cleaning or moving.
- This equipment should only be used in a flat, level position.
- Do not operate unattended.
- Any loose dirt or metal particles that are allowed to enter the gas lines on this equipment will damage the valve and affect its operation.
- If you smell gas, follow the instructions provided by the gas supplier. Do not touch any electrical switch; do not try to light the burner; do not use a telephone within close proximity.
- Never attempt to move grates while cooking.

**RESIDENTIAL USERS: vendor assumes no liability for parts or labor coverage for component failure or other damages resulting from installation in non-commercial or residential applications. The right is reserved to deny shipment for residential usage; if this occurs, you will be notified as soon as possible.**

## 1 YEAR PARTS AND LABOUR BENCH WARRANTY

Within the warranty period, contact Omcan Inc. at 1-800-465-0234 to schedule a drop off to either an Omcan authorized service depot in the area, or to an Omcan Service warehouse to repair the equipment.

Unauthorized maintenance will void the warranty. Warranty covers electrical and part failures, not improper use.

Please see <https://omcan.com/disclaimer> for complete info.

## Safety and Warranty

---

### WARNING:

The packaging components (cardboard, polyethylene, and others) are classified as normal solid urban waste and can therefore be disposed of without difficulty.

In any case, for suitable recycling, we suggest disposing of the products separately (differentiated waste) according to the current norms.

**DO NOT DISCARD ANY PACKAGING MATERIALS IN THE ENVIRONMENT!**

## Technical Specifications

---

<b>Model</b>	CE-CN-KJ-5
<b>Item Number</b>	47495
<b>Material</b>	Stainless Steel
<b>Gas Type</b>	Natural Gas
<b>Capacity</b>	20 Chickens
<b>BTU</b>	105,000
<b>Electrical</b>	110-120V / 60Hz / 1
<b>Number of Motors</b>	5
<b>Net Dimensions (WDH)</b>	46.7" x 19.3" x 44.1" / 1185 x 490 x 1120mm
<b>Conversion Kit</b>	Yes

## Installation

---

### SET UP

1. Remove all packing material and tape, as well as any protective plastic from the equipment.
2. Place the equipment in the desired position and height.
3. Clean and dry the equipment thoroughly before using.

The installation of this equipment must conform with local codes, or with the National Gas Code, ANSIZ223.1/

# Installation

---

NFPA 54, or the Natural Gas and Propane Installation Code, CSA B149.1, as applicable. The appliance must be electrically grounded in accordance with the National Electrical Code, NFPA 70, or the Canadian Electrical Code, CSA C22.2.

- The equipment and its individual shutoff valve must be disconnected from the gas supply piping system during any pressure testing of that system at test pressures in excess of ½ psi (3.5 kPa).
- The equipment must be isolated from the gas supply piping system by closing its individual manual shutoff valve during any pressure testing of the gas supply piping system at test pressures equal to or less than ½ psi (3.5 kPa).

## CLEARANCE AND POSITIONING AROUND THE EQUIPMENT

- This equipment must be installed adjacent to non-combustible surfaces only with a minimum spacing of 0" from all sides.

## AIR SUPPLY AND VENTILATION

- The area in front and around the equipment must be kept clear to avoid any obstruction of the flow of combustion and ventilation air.
- Adequate clearance must be maintained at all times in front of and at the sides of the equipment for servicing and proper ventilation.

## PRESSURE REGULATOR

- All commercial cooking equipment must have a pressure regulator on the incoming service line for safe and efficient operation. The regulator provided for this equipment is adaptable for both Natural gas and LP gas.
- Regulator specifications: ¾" NPT inlet and outlet, factory adjusted for 4" WC Natural Gas standard and may be converted by qualified personnel to be used for Propane at 10" WC.

Prior to connecting the regulator, check the incoming line pressure. The regulator can only withstand a maximum pressure of ½ PSI (14" WC). If the line pressure is beyond this limit, a step down regulator before the regulator provided will be required. The arrow above (FLOW) shows gas flow direction and should point downstream to the equipment.

# Installation

---

## PROPANE GAS CONVERSION

This rotisserie is shipped from the factory equipped with fixed burner orifices for natural gas operation. The burner orifices required to convert the rotisserie to propane gas are shipped with the rotisserie in the shipping packaging. It is recommended that a trained gas service technician with the necessary tools, instruments and skills perform the conversion. To convert to propane, following steps must be completed:

1. Remove all natural gas burner orifices and install the provided propane burner orifices.
2. Set the regulator to 10" W.C. by inverting the regulator spring plug like below pictures.

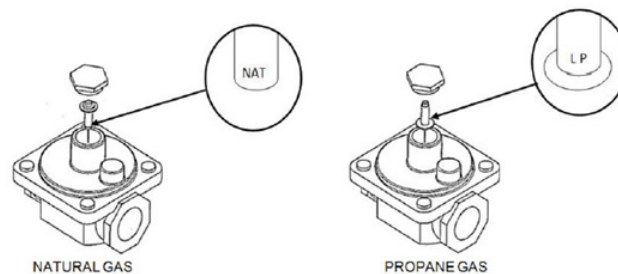

# Operation

---

## LIGHTING THE PILOT

The manifold units are equipped with standing pilots and each should be lit immediately after the gas is supplied to the equipment.

1. Before attempting to light the pilots, turn off the main gas valve to the equipment and wait 5 minutes to clear the gas.
2. Turn off all gas control knobs.
3. Turn on control valve and light all pilots.
4. The pilot burner must be lit from the top. Hold an ignition source and light the pilot. When the flame is stable, remove ignition source.
5. Turn off the main gas valve to shut down the equipment.

There is one pilot for each burner. The rotisserie is equipped with standing, unmonitored pilots. Gas will flow from the pilots as soon as the main gas supply to the unit is turned on. Standing pilots should be adjusted to provide a slight yellow tip on the flame. Air shutters on the main burners must be individually adjusted to provide a blue flame. All traces of yellow should be adjusted out of the burner flame.

The rotisserie is a free vented appliance. All products of combustion and the heat generated by the burners pass through the grates. When meat is placed on the grates, this blocks the venting and causes a temperature build-up.



# Operation

---

## PILOT FLAME HEIGHT ADJUSTMENT

- The pilot flame on the equipment has been factory adjusted. When adjustment is necessary, adjust the pilot flames as small as possible but high enough to light the burner immediately when the burner valve is turned to the highest setting. Access to the pilot flame adjustment screw is obtained through the holes in the front panel.

Turn the main power switch ON. Each power switch controls each spit independently. Allow the rotisserie to preheat for 30 minutes. Each spit is able to cook 5 chickens in 45 minutes. After 30 minutes of burn-in, equipment is ready for use.

## OPERATION

1. To ignite the burners, depress and turn the gas control knob to high position.
2. Turn on the motor and chamber light switch when in need.

## SHUTDOWN INSTRUCTIONS

After cooking is done, please turn the valve to off position and turn off the motor switch, light switch and main power switch, then cut off the gas and power supply.

# Maintenance

---

## COMPONENT PARTS

The rotisserie comes with several standard parts as illustrated. Each can be easily removed and installed easily by hand for cleaning and maintenance. Note that the Burner and Deflector are an assembly and are NOT designed to be disassembled.

## CLEANING

Spits may be immersed in strong commercial cleaning compound overnight. In the morning, rinse with hot water to remove any residues of cleaning compound. Thoroughly dry and apply cooking oil to prevent rusting. Stainless steel surfaces may be cleaned using damp cloth with mild detergent and water solution. Places where fat, grease, or food can accumulate must be cleaned regularly.

## MAINTENANCE

- A qualified service company should check the unit for safe and efficient operation on an annual basis.
- Gas piping shall be a certain size and installed to provide a supply of gas sufficient to meet the full gas input of the equipment.

# Maintenance

---

- A manual shut off valve should be installed upstream from the manifold within 4 ft. (1.2m) of the equipment and in a position where it can be reached in the event of an emergency.
- Check entire gas piping system for leaks every so often. Using a gas leak detector or soapy water solution is recommended.
- Install equipment under efficient exhaust hood with flameproof filters with a distance of no less than 4 feet between the top of the equipment and the filters or any other combustible materials.

**\*Shipped setup for Natural Gas and includes a kit for conversion to LPG.**

## LEVELING

It is important that the rotisserie is level front to back and left to right. Areas of uneven heat distribution will occur on an unlevelled unit. The unit should be rechecked for level anytime it has been moved.

## VENTILATION HOOD

The rotisserie should be installed under a suitable ventilation hood. For safe operation and proper ventilation, keep the space between the rotisserie and vent hood free from any obstructions.

# Troubleshooting

---

PROBLEM	POSSIBLE CAUSES
Uneven heating, sides burning.	Burner valves improperly adjusted.
	Fluctuating gas pressure.
	Improperly adjusted burner.
Too much top heat.	Burner valves adjusted too high.
	Faulty ventilation.
	OVERRATED gas pressure.
	Improperly adjusted burner.
Uneven heat side to side.	Burner valves improperly adjusted.
	Appliance is not level side to side.
	Improperly adjusted burner.
Pilot outage.	Pilot flame is set too low. Adjust pilot to allow for gas flow.
	Obstruction in pilot orifice.
	Low gas pressure.

## ***Troubleshooting***

---

Yellow burner flames.	Open burner shutters until flames are blue.
Lifting burner flames.	Close burner shutters until flames touch burner.
Fluctuating gas pressure.	Check for clogged vent on regulator.

# Parts Breakdown

Model **CE-CN-KJ-5** 47495

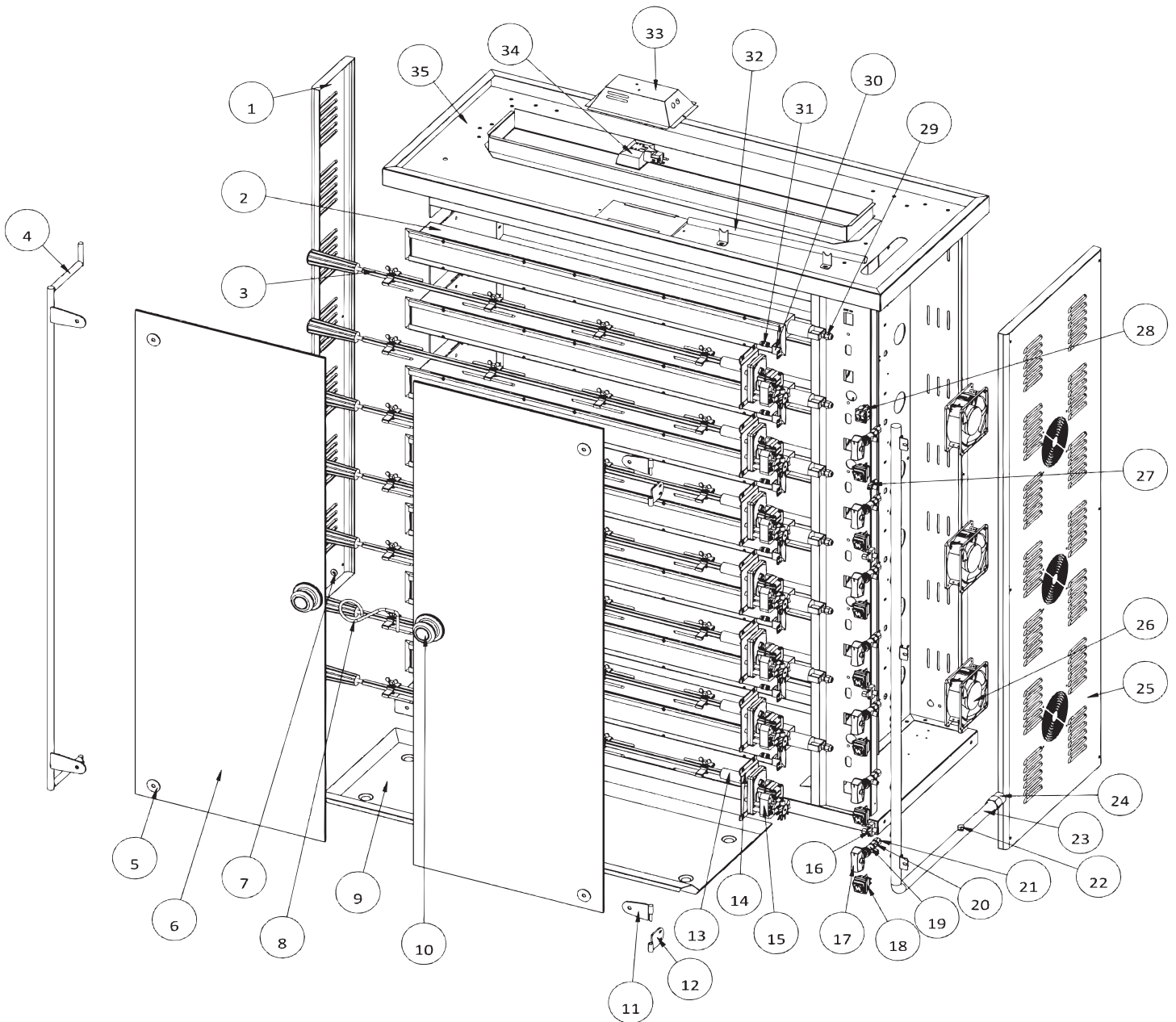

# Parts Breakdown

## Model CE-CN-KJ-5 47495

Item No.	Description	Position	Item No.	Description	Position	Item No.	Description	Position
AK268	Left Panel for 47495	1	AK280	Motor Shaft for 47495	13	AK290	Right Panel for 47495	25
AK269	Burner Assembly for 47495	2	AK281	Motor Mounting Plate for 47495	14	AK291	Fan for 47495	26
AK270	Spit Assembly for 47495	3	AD558	Motor 230V/50Hz for 47495	15	66207	Pilot Valve (Griddle) Single AP7 for 47495	27
AK271	Left Door Swing Arm Welding Assembly for 47495	4	66206	Pilot Valve (Open Burner) Dual AP6 for 47495	16	AK293	Dual Switch for 47495	28
AK272	Gasket A for Glass Door for 47495	5	AK284	Knob for 47495	17	AK294	Nozzle for 47495	29
AK273	Door Glass for 47495	6	AD712	Power Switch for 47495	18	AK295	Pilot Bracket for 47495	30
AK274	Gasket B for Glass Door for 47495	7	AK285	A18 Gas Control Valve for 47495	19	66208	Pilot for 47495	31
AK275	Glass Door Lock for 47495	8	AK286	Valve Adapter for 47495	20	AK296	Electrical Wire Conduit for 47495	32
AK276	Oil Drip Tray Pan for 47495	9	AK287	8 Copper Nut for 47495	21	AK297	Guard Plate for Light Stand for 47495	33
AK277	Bakelite Handle for 47495	10	AJ605	Test Plug for 47495	22	AK298	Light Holder + 25W Light Bulb for 47495	34
AK278	Right Glass Door Hinge A for 47495	11	AK288	Gas Air Intake Pipe Assembly for 47495	23			
AK279	Right Glass Door Hinge B for 47495	12	AK289	Intake Pipe Adapter for 47495	24			

# Electrical Schematics

**Model CE-CN-KJ-5** 47495

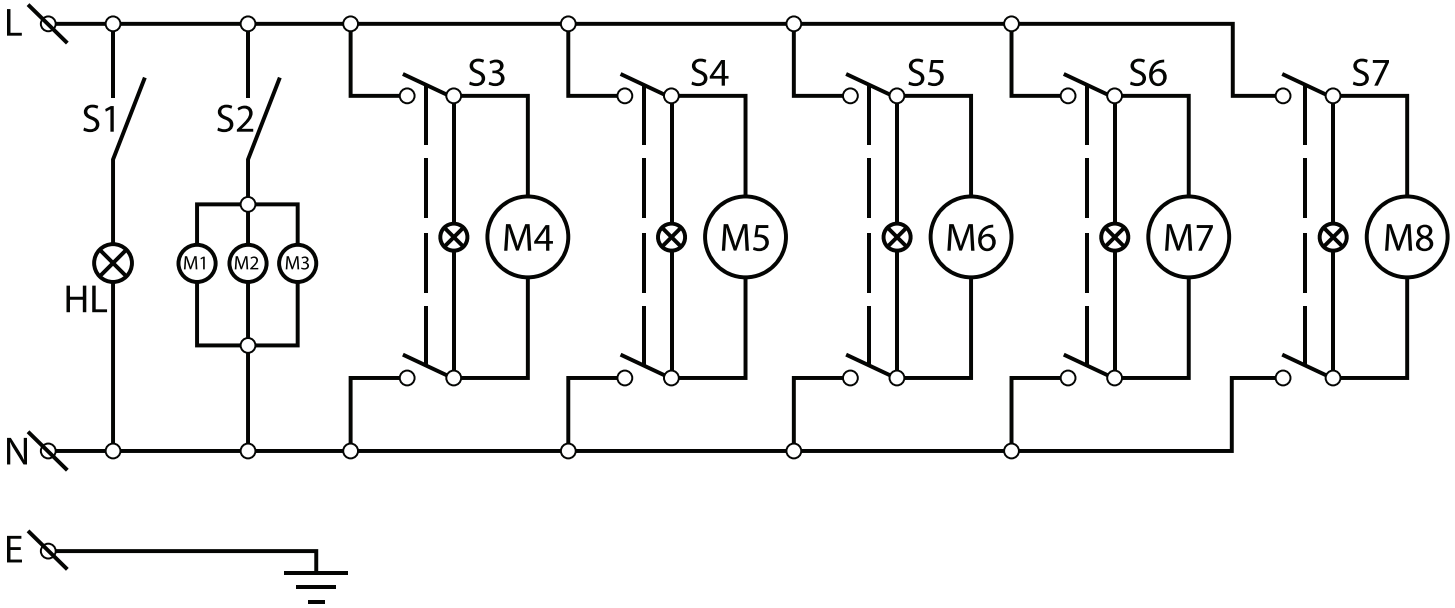

S1-S2: Switch for controlling fan and chamber illuminator

S3-S7: Switch for controlling motor

M1-M3: Fan

M4-M8: Motor

HL: Chamber illuminator

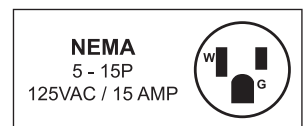



# Warranty Registration

Thank you for purchasing an Omcan product. To register your warranty for this product, complete the information below, tear off the card at the perforation and then send to the address specified below. You can also register online by visiting:

Merci d'avoir acheté un produit Omcan. Pour enregistrer votre garantie pour ce produit, complétez les informations ci-dessous, détachez la carte au niveau de la perforation, puis l'envoyer à l'adresse spécifiée ci-dessous. Vous pouvez également vous inscrire en ligne en visitant:

Gracias por comprar un producto Omcan usted. Para registrar su garantía para este producto, complete la información a continuación, cortar la tarjeta en la perforación y luego enviarlo a la dirección indicada a continuación. También puede registrarse en línea en:

<https://omcan.com/warranty-registration/>

For mailing in Canada

Pour postale au Canada

Por correo en Canadá

For mailing in the US

Pour diffusion aux États-Unis

Por correo en los EE.UU.

**OMCAN**

PRODUCT WARRANTY REGISTRATION

3115 Pepper Mill Court,  
Mississauga, Ontario  
Canada, L5L 4X5

**OMCAN**

PRODUCT WARRANTY REGISTRATION

4450 Witmer Industrial Estates, Unit 4,  
Niagara Falls, New York  
USA, 14305

*or email to: [service@omcan.com](mailto:service@omcan.com)*



Purchaser's Information

Name: \_\_\_\_\_

Address: \_\_\_\_\_

City: \_\_\_\_\_ Province or State: \_\_\_\_\_ Postal or Zip: \_\_\_\_\_

Country: \_\_\_\_\_

Dealer from which Purchased: \_\_\_\_\_

Dealer City: \_\_\_\_\_ Dealer Province or State: \_\_\_\_\_

Invoice: \_\_\_\_\_

Model Name: \_\_\_\_\_ Model Number: \_\_\_\_\_

Machine Description: \_\_\_\_\_

Date of Purchase (MM/DD/YYYY): \_\_\_\_\_

Would you like to extend the warranty?  Yes  No

Company Name: \_\_\_\_\_

Telephone: \_\_\_\_\_

Email Address: \_\_\_\_\_

Type of Company:

Restaurant  Bakery  Deli

Butcher  Supermarket  Caterer

Institution (*specify*): \_\_\_\_\_

Other (*specify*): \_\_\_\_\_

Serial Number: \_\_\_\_\_

Date of Installation (MM/DD/YYYY): \_\_\_\_\_

**Thank you for choosing Omcan | Merci d'avoir choisi Omcan | Gracias por elegir Omcan**



Since 1951 Omcan has grown to become a leading distributor of equipment and supplies to the North American food service industry. Our success over these many years can be attributed to our commitment to strengthen and develop new and existing relationships with our valued customers and manufacturers. Today with partners in North America, Europe, Asia and South America, we continually work to improve and grow the company. We strive to offer customers exceptional value through our qualified local sales and service representatives who provide convenient access to over 6,500 globally sourced products.

---

Depuis 1951 Omcan a grandi pour devenir un des "leaders" de la distribution des équipements et matériel pour l'industrie des services alimentaires en Amérique du Nord. Notre succès au cours de ces nombreuses années peut être attribué à notre engagement à renforcer et à développer de nouvelles et existantes relations avec nos clients et les fabricants de valeur. Aujourd'hui avec des partenaires en Amérique du Nord, Europe, Asie et Amérique du Sud, nous travaillons continuellement à améliorer et développer l'entreprise. Nous nous efforçons d'offrir à nos clients une valeur exceptionnelle grâce à nos ventes locales qualifiées et des représentants de service qui offrent un accès facile à plus de 6500 produits provenant du monde entier.

---

Desde 1951 Omcan ha crecido hasta convertirse en un líder en la distribución de equipos y suministros de alimentos en América del Norte industria de servicios. Nuestro éxito en estos años se puede atribuir a nuestro compromiso de fortalecer y desarrollar nuevas relaciones existentes con nuestros valiosos clientes y fabricantes. Hoy con socios de América del Norte, Europa, Asia y América del Sur, que trabajan continuamente para mejorar y crecer la empresa. Nos esforzamos por ofrecer a nuestros clientes valor excepcional a través de nuestro local de ventas y representantes de los servicios que proporcionan un fácil acceso a más de 6,500 productos con origen a nivel mundial.

