

UNDERCOUNTER HIGH TEMPERATURE
DISHWASHER, GLASSWASHER & SANITIZER

H54E-A



60 years of experience with evolving technology has produced the HANDY H54E-A. Thesis offers a professional wash system, designed and created to provide excellent cleaning, hygiene and brightness. The H54E-A is simple to use for heavy duty applications with low maintenance. It's your perfect solution for cleaning and sanitizing dishes, glasses, cups, mugs, cutlery and more. We guarantee an impeccable wash quality, which can meet even the needs of the most sophisticated customers.

Functions and benefits without compromise, all with lower running costs and at a very reasonable price.

Ecoclean: Water control system for partial clean water refill in every wash cycle.

Stainless steel: Adjustable rotation speed rinse arms, integral tank filter, with detergent injector welded to the tank.

ETL Sanitation: Programmed to guarantee the perfect sanitation result at high rinse temperatures.

Multi power: Adapt the power level to your needs. Choose the maximum power for the highest production requirements or reduce consumption with a low power set up.

LCD controls: Simple digital control panel with digital temperature display for intuitive and user-friendly operation.

High-quality products built using durable stainless steel with electromechanical components. The H54E-A is designed for energy savings with lower water and detergent consumption.



Intertek



Intertek

Dealer Stamp:

H54E-A



Technical features

- Control panel with LCD display
- ETL Sanitation to guarantee a powerful wash and sanitization with a high rinse temperature
- EWC System, electronic control with 4 individual programmable cycles
- Built in drain pump with Ecology Care system for partial refilling of clean water in every washing cycle
- Vacuum breaker valve
- Integral stainless steel tank filter + New filtering group for suction and drain
- Racks supplied: 1 dish basket, 1 glass basket, and 2 cutlery trays
- 1-year parts and labour warranty
- Adjustable 3L/hour detergent dispenser
- Adjustable 0.3L/hour rinse-aid dispenser
- 40 racks/hour or approximately 35 racks/hour in accordance with NSF standards

Uses standard racks	20" x 20" (500 x 500mm)
Door clearance	15.08" (383mm) height
Wash pump	3/4HP
Tank heating element	2.6kW, capacity: 7gal (26L)
Booster heating element	2.5kW, capacity: 1.9gal (7.3L)
Power requirements	3.12kW, 208/220V 50/60Hz, 15A 1PH
Hot water requirements	½ GPC (2.6LPC) 125°F (55°C), will operate with cold water at reduced capacity
Water line requirements	¾" (or ½" with ¾" NPT terminal) hose supplied
Water pressure requirements	30–45psi (2–3bar)
Drain line	1" (25mm) connection hose supplied
Dimensions	23"W x 24"D x 31¾"H (585W x 610D x 815H mm)
Weight	126lbs (57.5kg)
Shipping dimensions	26¾"W x 31½"D x 39½"H (680W x 800D x 1000H mm)
Shipping weight	153lbs (69.2kg)

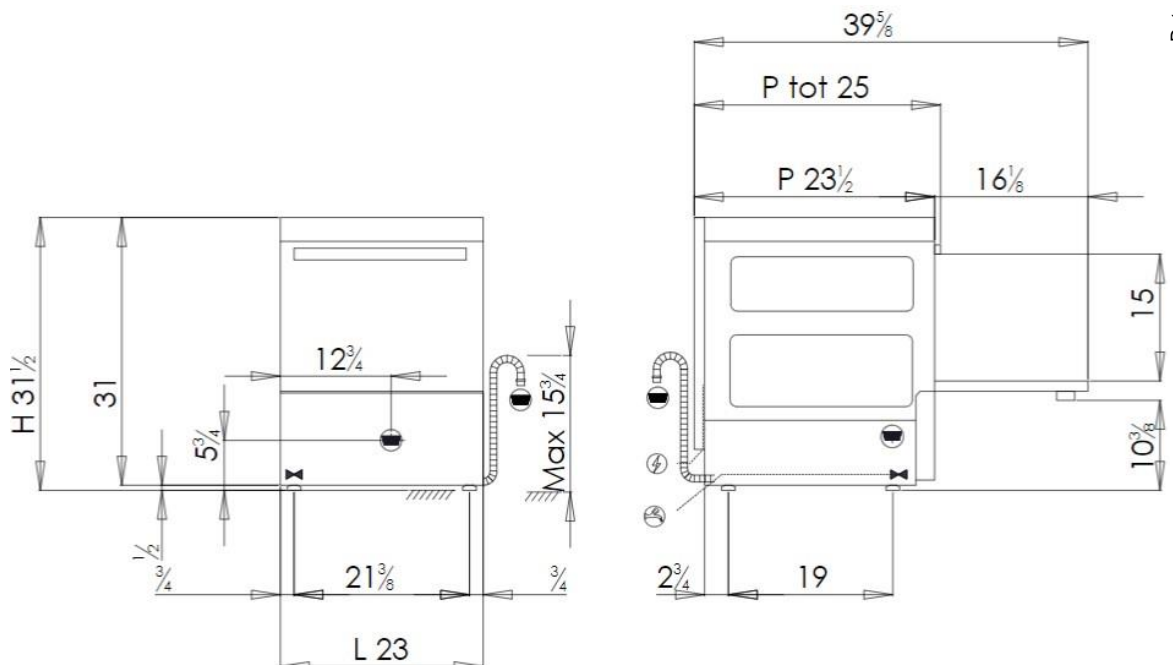

Data are indicative. In the event of further development, we reserve the right to alter our design specification without notice.