



Back Bar Bottle Coolers

Models BB-CN-0012-GH, 0012-SH, 0016-GH, 0016-SH, 0020-GH, 0020-SH
Items 50058, 50057, 50060, 50059, 50062, 50061

Instruction Manual



Revised - 12/08/2023



Intertek



Intertek

Toll Free: 1-800-465-0234
Fax: 905-607-0234
Email: service@omcan.com
www.omcan.com



Table of Contents

Model BB-CN-0012-GH / Model BB-CN-0016-GH / Model BB-CN-0020-GH
Model BB-CN-0012-SH / Model BB-CN-0016-SH / Model BB-CN-0020-SH

Section	Page
Disclaimer -----	3
General Information -----	4 - 5
Safety and Warranty -----	5 - 8
Technical Specifications -----	8 - 9
Installation -----	9 - 10
Operation -----	11 - 13
Cleaning and Maintenance -----	13 - 15
Parts Breakdown -----	16 - 27
Electrical Schematics -----	28 - 30
Warranty Registration -----	31

Disclaimer

OMCAN IS NOT RESPONSIBLE FOR ANY DAMAGES DUE TO WATER LEAKS. WARRANTY FOR WATER LEAKS IS VOID IF THE AMBIENT ROOM TEMPERATURE EXCEEDS 75°F AND 55% RELATIVE HUMIDITY, AND THE APPLIANCE DRAIN IS NOT CONNECTED DIRECTLY TO A FLOOR DRAIN.

OMCAN N'EST PAS RESPONSABLE DES DOMMAGES DUS AUX FUITES D'EAU. LA GARANTIE POUR LES FUITES D'EAU EST ANNULÉE SI LA TEMPÉRATURE AMBIANTE DE LA PIÈCE DÉPASSE 75°F ET 55% D'HUMIDITÉ RELATIVE, ET SI LE DRAIN DE L'APPAREIL N'EST PAS RACCORDÉ DIRECTEMENT À UN DRAIN DE PLANCHER.

OMCAN NO SE HACE RESPONSABLE DE LOS DAÑOS CAUSADOS POR FUGAS DE AGUA. LA GARANTÍA POR FUGAS DE AGUA QUEDA ANULADA SI LA TEMPERATURA AMBIENTE SUPERA LOS 75°F Y EL 55% DE HUMEDAD RELATIVA, Y EL DESAGÜE DEL APARATO NO ESTÁ CONECTADO DIRECTAMENTE A UN DESAGÜE DE PISO.

General Information

Omcan Manufacturing and Distributing Company Inc., Food Machinery of America, Inc. dba Omcan and Omcan Inc. are not responsible for any harm or injury caused due to any person's improper or negligent use of this equipment. The product shall only be operated by someone over the age of 18, of sound mind, and not under the influence of any drugs or alcohol, who has been trained in the correct operation of this machine, and is wearing authorized, proper safety clothing. Any modification to the machine voids any warranty, and may cause harm to individuals using the machine or in the vicinity of the machine while in operation.

CHECK PACKAGE UPON ARRIVAL

Upon receipt of an Omcan shipment please inspect for external damage. If no damage is evident on the external packaging, open carton to ensure all ordered items are within the box, and there is no concealed damage to the machine. If the package has suffered rough handling, bumps or damage (visible or concealed), please note it on the bill of lading before accepting the delivery and contact Omcan within 24 hours, so we may initiate a claim with the carrier. A detailed report on the extent of the damage caused to the machine must be filled out within three days, from the delivery date shown in the shipping documents. Omcan has no recourse for damaged products that were shipped collect or third party.

Before operating any equipment, always read and familiarize yourself with all operation and safety instructions.

Omcan would like to thank you for purchasing this machine. It's of the utmost importance to save these instructions for future reference. Also save the original box and packaging for shipping the equipment if servicing or returning of the machine is required.

Omcan Fabrication et distribution Compagnie Limitée et Food Machinery d'Amérique, dba Omcan et Omcan Inc. ne sont pas responsables de tout dommage ou blessure causé du fait que toute personne ait utilisé cet équipement de façon irrégulière. Le produit ne doit être exploité que par quelqu'un de plus de 18 ans, sain d'esprit, et pas sous l'influence d'une drogue ou d'alcool, qui a été formé pour utiliser cette machine correctement, et est vêtu de vêtements de sécurité appropriés. Toute modification de la machine annule toute garantie, et peut causer un préjudice à des personnes utilisant la machine ou des personnes à proximité de la machine pendant son fonctionnement.

VÉRIFIEZ LE COLIS DÈS RÉCEPTION

Dès réception d'une expédition d'Omcan veuillez inspecter pour dommages externes. Si aucun dommage n'est visible sur l'emballage externe, ouvrez le carton afin de s'assurer que tous les éléments commandés sont dans la boîte, et il n'y a aucun dommage dissimulé à la machine. Si le colis n'a subi aucune mauvaises manipulations, de bosses ou de dommages (visible ou cachée), notez-le sur le bond de livraison avant d'accepter la livraison et contactez Omcan dans les 24 heures qui suivent, pour que nous puissions engager une réclamation auprès du transporteur. Un rapport détaillé sur l'étendue des dommages causés à la machine doit être rempli dans un délai de trois jours, à compter de la date de livraison indiquée dans les documents d'expédition. Omcan n'a aucun droit de recours pour les produits endommagés qui ont été expédiés ou cueilli par un tiers transporteur.

General Information

Avant d'utiliser n'importe quel équipement, toujours lire et vous familiariser avec toutes les opérations et les consignes de sécurité.

Omcan voudrais vous remercier d'avoir choisi cette machine. Il est primordial de conserver ces instructions pour une référence ultérieure. Également conservez la boîte originale et l'emballage pour l'expédition de l'équipement si l'entretien ou le retour de la machine est nécessaire.

Omcan Empresa De Fabricacion Y Distribucion Inc. Y Maquinaria De Alimentos De America, Inc. dba Omcan y Omcan Inc. no son responsables de ningun daño o perjuicio causado por cualquier persona inadecuada o el uso descuidado de este equipo. El producto solo podra ser operado por una persona mayor de 18 años, en su sano juicio y no bajo alguna influencia de droga o alcohol, y que este ha sido entrenado en el correcto funcionamiento de esta máquina, y ésta usando ropa apropiada y autorizada. Cualquier modificación a la máquina anula la garantía y puede causar daños a las personas usando la máquina mientras esta en el funcionamiento.

REVISE EL PAQUETE A SU LLEGADA

Tras la recepcion de un envio Omcan favor inspeccionar daños externos. Si no hay daños evidentes en el empaque exterior, Habra el carton para asegurarse que todos los articulos solicitados estén dentro de la caja y no encuentre daños ocultos en la máquina. Si el paquete ha sufrido un manejo de poco cuidado, golpes o daños (visible o oculto) por favor anote en la factura antes de aceptar la entrega y contacte Omcan dentro de las 24 horas, de modo que podamos iniciar una reclamación con la compañía. Un informe detallado sobre los daños causados a la máquina debe ser llenado en el plazo de tres días, desde la fecha de entrega que se muestra en los documentos de envío. Omcan no tiene ningun recurso por productos dañados que se enviaron a recoger por terceros.

Antes de utilizar cualquier equipo, siempre lea y familiarizarse con todas las instrucciones de funcionamiento y seguridad.

Omcan le gustaría darle las gracias por la compra de esta máquina. Es de la mayor importancia para salvar estas instrucciones para futuras consultas. Además, guarda la caja original y el embalaje para el envío del equipo si servicio técnico o devolución de la máquina que se requiere.

Safety and Warranty

When using electrical appliances basic safety precautions should be followed:

- This cooler must be properly installed and located in accordance with the installation service representative.
- Do not allow children to climb, stand or hang on the shelves in the cooler. They could damage the unit and seriously injure themselves.
- Do not store or use gasoline or other flammable vapors and liquids in the vicinity of this or any other appliance.

Safety and Warranty

- Unplug the unit from the electrical outlet before cleaning or making repairs.
- Setting the temperature controls to the 0 (zero) position does not remove power to the light circuit, perimeter heaters or evaporator fans.

NOTE: it is strongly recommended that any servicing be performed by an authorized instructions before it is used.

ELECTRICAL SAFETY

Do not under any circumstances cut or remove the grounding prong from the power cord. For safety this appliance must be properly grounded at all times.

- The power cord of this cooler is equipped with a grounding plug which mates with a standard grounding wall outlet to minimize the possibility of electric shock hazard.
- If the outlet is a standard 2-prong outlet, it must be replaced with the properly grounded wall outlet. **NEVER USE AN ADAPTER PLUG!**
- Have the wall outlet and circuit checked by a qualified electrician to make sure the outlet is properly grounded. Check the incoming voltage with a voltmeter.
- **DO NOT USE EXTENSION CORDS.** The use of extension cords to connect the cooler will void warranty. The unit must be close enough to the electrical supply so that extension cords are never used.
- The cooler should always be plugged into its own dedicated circuit with a voltage rating that matches the rating plate. This provides the best performance and also prevents overloading wiring circuits which could become a fire hazard from overheated wires.
- Never unplug your cooler by pulling on the power cord. Always grip the plug firmly and pull straight out from the outlet.
- Repair or replace immediately all power cords that have become frayed or otherwise damaged. Do not use a power cord that has cracks or abrasion damage along its length or at either of its ends.
- When removing the cooler away from the wall be careful not to run over or damage the power cord.
- When the cooler is installed or used, all the packaging (including carton and plastic wrap) should be removed.
- Keep the cooler stable to avoid vibration and noise.
- The cooler should be installed in a place with good ventilation and a space of at least 6" should be allowed between the surrounding walls and the cabinet wall for air circulation.
- Unit should be placed far from any heating source to avoid decrease of refrigeration efficiency.
- Install the cooler in a dry place to prevent rust from forming on the compartment body, which may affect the electrical insulation.

Service must only be performed by an authorized service representative, please call Omcan for a local service company.

NOTE: wiring diagram can be referenced by removing the front louvered grill, and looking on the inside cabinet wall electrical supply so that extension cords are never used.

CAUTION

- The cooler must be grounded correctly, never with a heating pipe and coal gas pipe.



Safety and Warranty

- In case of damage to electrical cord and plug, please contact after sale service and never do it yourself.
- When unplugging unit, please grasp by the plug, not the cord.
- If the voltage is unstable, please select a suitable automatic voltage regulator.
- If the power cuts off, you should wait for at least 5 minutes before turning on the unit again to avoid damage to the compressor.
- Never store any flammable, explosive or corrosive liquid or gas in or near the cooler.

PROPER DISPOSAL OF EQUIPMENT; DANGER! RISK OF CHILD ENTRAPMENT

Child entrapment and suffocation are not problems of the past. Junked or abandoned refrigerators are still dangerous, even if they will sit for “just a few days.” If you are getting rid of an old refrigerator, please follow the below instructions to help prevent a terrible accident.

- Remove the doors.
- Leave shelves in place to prevent children from easily climbing inside.

REFRIGERANT DISPOSAL

Your old refrigerator may have a cooling system that used “ozone depleting” chemicals. If you are throwing away your old refrigerator, be sure the refrigerant is removed for proper disposal by a qualified service technician. If you intentionally release any refrigerants you can be subject to fines and imprisonment under the provisions of the environmental regulations.

RESIDENTIAL USERS: vendor assumes no liability for parts or labor coverage for component failure or other damages resulting from installation in non-commercial or residential applications. The right is reserved to deny shipment for residential usage; if this occurs, you will be notified as soon as possible.

2 YEARS PARTS AND LABOUR / 5 YEARS PARTS ONLY ON COMPRESSOR WARRANTY

Within the warranty period, contact Omcan Inc. at 1-800-465-0234 to schedule an Omcan authorized service technician to repair the equipment locally.

Unauthorized maintenance will void the warranty. Warranty covers electrical and part failures, not improper use.

Please see <https://omcan.com/disclaimer> for complete info.

WARNING:

The packaging components are classified as normal solid urban waste and can therefore be disposed of without difficulty.

In any case, for suitable recycling, we suggest disposing of the products separately (differentiated

Safety and Warranty

waste) according to the current norms.

DO NOT DISCARD ANY PACKAGING MATERIALS IN THE ENVIRONMENT!

Technical Specifications

GLASS DOOR BOTTLE COOLERS

Model	BB-CN-0012-GH	BB-CN-0016-GH	BB-CN-0020-GH
Power	1/5 HP		1/4+ HP
Product Capacity	672 - 12 oz. cans	912 - 12 oz. cans	1152 - 12 oz. cans
	2 - kegs		3 - kegs
	384 - 12 oz. bottles	504 - 12 oz. bottles	624 - 12 oz. bottles
Number of Doors	2		3
Temperature Range	0.5 - 5°C / 32.9 - 41°F		
Max Ambient Temp Rating	24°C / 75°F		
Capacity	335 L / 11.8 cu.ft.	446 L / 15.8 cu.ft.	556 L / 19.6 cu.ft.
Number of Shelves	4		6
Electrical	110-120V / 60Hz / 1		
Current	2.88A		3.96A
Refrigerant	R290		
Dimensions	48.8" x 24.4" x 35.6" 1240 x 620 x 905mm	60.8" x 24.4" x 35.6" 1544 x 620 x 905mm	72.8" x 24.4" x 35.6" 1848 x 620 x 905mm
Interior Dimensions	36.2" x 18.5" x 30.5" 920 x 470 x 775mm	20" x 48.2" x 31" 507 x 1224 x 787mm	60.2" x 18.5" x 30.5" 1528 x 470 x 775mm
Packaging Dimensions	51.2" x 27.6" x 42.3" 1300 x 700 x 1075mm	27.6" x 63.4" x 42.3" 701 x 1610 x 1074mm	75.2" x 27.6" x 42.3" 1910 x 700 x 1075mm
Weight	216.1 lbs. / 98 kgs.	326.3 lbs. / 148 kgs.	310.9 lbs. / 141 kgs.
Packaging Weight	260.1 lbs. / 118 kgs.	381.4 lbs. / 173 kgs.	385.8 lbs. / 175 kgs.
Item Number	50058	50060	50062



Technical Specifications

SOLID DOOR BOTTLE COOLERS

Model	BB-CN-0012-SH	BB-CN-0016-SH	BB-CN-0020-SH
Power	1/5 HP		1/4+ HP
Product Capacity	672 - 12 oz. cans	912 - 12 oz. cans	1152 - 12 oz. cans
	2 - kegs		3 - kegs
	384 - 12 oz. bottles	504 - 12 oz. bottles	624 - 12 oz. bottles
Number of Doors	2		3
Temperature Range	0.5 - 5°C / 32.9 - 41°F		
Max Ambient Temp Rating	24°C / 75°F		
Capacity	335 L / 11.8 cu.ft.	446 L / 15.8 cu.ft.	556 L / 19.6 cu.ft.
Number of Shelves	4		6
Electrical	110-120V / 60Hz / 1		
Current	2.88A		3.96A
Refrigerant	R290		
Dimensions	48.8" x 24.4" x 37.2" 1240 x 620 x 945mm	60.8" x 24.4" x 37.2" 1544 x 620 x 945mm	72.8" x 24.4" x 37.2" 1848 x 620 x 945mm
Interior Dimensions	36.2" x 18.5" x 30.5" 920 x 470 x 775mm	48.2" x 18.5" x 30.5" 1224 x 470 x 775mm	60.2" x 18.5" x 30.5" 1528 x 470 x 775mm
Packaging Dimensions	51.2" x 27.6" x 42.3" 1300 x 700 x 1075mm	63.4" x 27.6" x 42.3" 1610 x 700 x 1075mm	75.2" x 27.6" x 42.3" 1910 x 700 x 1075mm
Weight	216.1 lbs. / 98 kgs.	255.7 lbs. / 116 kgs.	310.9 lbs. / 141 kgs.
Packaging Weight	260.1 lbs. / 118 kgs.	319.7 lbs. / 145 kgs.	385.8 lbs. / 175 kgs.
Item Number	50057	50059	50061

Installation

Tools required: Phillips screw driver.

- Use a Phillips screw driver to remove the four (4) screws from the L-bracket connecting the unit to the wood skid. Then remove the L-bracket from the unit.
- Remove skid by unscrewing all base rail anchor brackets. Place skid to the side.
- Carefully upright cabinet.

When lifting unit do not use the counter top as a lifting point. Also remember to leave cabinet upright for 24-hours before plugging into power source.

- Set unit in its final location. Make sure there is adequate ventilation in this location. Under extreme heat

Installation

conditions (+100°F / +38°C) an exhaust fan may be necessary.

- Proper leveling of the unit is critical to operating success (for non-mobile models). Effective condensate removal and door operation will be affected by leveling.
- The cooler should be leveled front to back and side to side with a level.

Warning: installation without proper ventilation will void the manufacturer's warranty.

SEALING CABINET TO FLOOR

STEP 1 - POSITION CABINET

Allow six (6) inches between the wall and rear of the refrigerated bar equipment to assure proper ventilation.

STEP 2 - LEVEL CABINET

Cabinet should be level side to side and front to back. Place a carpenter's level in the interior cabinet floor in four places:

A - position level in the inside floor of the unit near the door. Level should be parallel to cabinet front.

B - position level at the inside rear of cabinet. Level should be placed parallel to cabinet back.

C - perform similar procedures to steps A and B by placing the level on inside floor left and right sides parallel to the depth of the cooler. Level cabinet.

STEP 3 - APPLYING SEALANT

- Draw an outline on the base of the floor.
- Raise and block the front side of the cabinet.
- Apply a bead of NSF approved sealant (see list below) to floor half an inch inside the outline drawn. The bead must be heavy enough to seal the entire cabinet surface when it set down on the sealant.
- Raise and block the rear of the cabinet.
- Apply sealant on floor as outlined above on other 3 sides.
- Examine to see that the cabinet is sealed to floor around entire perimeter.

NSF APPROVED SEALANTS:

- Minnesota Mining #ECU800 Caulk.
- Minnesota Mining #ECU2185 Caulk.
- Minnesota Mining #ECU1055 Bead.
- Minnesota Mining #ECU1202 Bead.
- Armstrong Cork - Rubber Caulk.
- Products Research Co #5000 Rubber Caulk.
- GE Silicone Sealer.
- Dow Corning Silicone Sealer.

NOTE: asphalt floors are very susceptible to chemical attack. A layer of tape on the floor prior to applying the sealant will protect the floor.

START UP

Plug in the cooler and the compressor is ready to operate.

- Temperature control set at #4 position gives the cooler an approximate temperature of 35°F. Allow unit to function several hours, completely cooling cabinet before changing the control setting.
- Excessive tampering with the control could lead to service difficulties. Should it ever become necessary to replace the temperature control it should be ordered from your dealer or recommended service agent.
- Good air flow in your cooler is critical. Be careful to load product so that it neither presses against the back wall nor comes within four (4) inches of the evaporator housing. Refrigerated air off the coil must circulate down the back wall.

LIGHT SWITCH LOCATION:

The switch is located on the front of the evaporator housing toward the right of the cabinet. Open the front door.

NOTE: if the unit is disconnected or shut off, wait five (5) minutes before re-starting unit.

RECOMMENDATION

Before loading product the unit should be run for 2 to 3 days. This allows confirmation that the electrical wiring and installation are correct and no shipping damage has occurred. Remember that the factory warranty does not cover product loss.

REPLACEMENT PARTS

Maintain a record of the cabinet model number and serial number for your cooler. If at any time during the life of your cooler a replacement part is needed, call the factory office with the model number and serial number of your unit to place an order for the part.

CONTROLLER INSTRUCTIONS

Digital controller model: PJEZ for cooler



Dimensioni (mm) / Dimensions (mm)

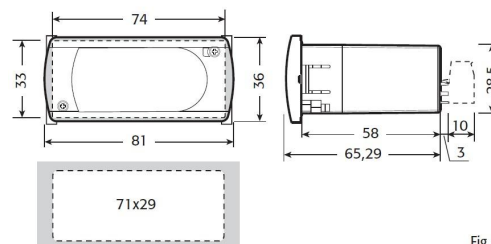

Fig. 1

Operation

DISPLAY AND FUNCTIONS

During normal operation, the controller displays the value of the probe set using parameter/4(=1 ambient probe, default, = 2 second probe, = 3 third probe). In addition, the display has LEDs that indicate the activation of the control functions (see table 1), while the 3 buttons can be used to activate/deactivate some of the functions (see table 2).

LED'S AND ASSOCIATED FUNCTIONS (TABLE 1)









Icon	Function	Normal Operation			Start Up
		ON	OFF	Blink	
	Compressor	On	Off	Request	ON
	Fan	On	Off	Request	ON
	Defrost	On	Off	Request	ON
<i>AUX</i>	Aux	Output On	Output Off	-	ON
	Alarm	All	No Alarm	-	ON
	Clock	RTC fitted and enabled, at least 1 time band set	RTC not fitted or disabled, not even 1 time band set	-	ON if RTC fitted

TABLE OF FUNCTIONS ACTIVATED BY THE BUTTONS - MODELS S, X, Y, C (TABLE 2)

Button	Normal Operation		Start Up	
	Pressing the Button Alone	Pressed Together		
	Up ON/OFF	More than 3 sec: toggle ON/OFF	-	
	Down Defrost	More than 3 sec: start/stop defrost	Pressed together Start parameter reset procedure	For 1 sec. display firmware vers. code
	Set Mute	- 1 sec.: display/set the set point. - more than 3 secs.: access parameter setting menu (enter password) - mute audible alarm (buzzer)		For 1 sec. RESET current EZY set

SETTING THE SET POINT (DESIRED TEMPERATURE)

- Press **SET** for 1 sec, the set value will start flashing after a few moments.
- Increase or decrease the value using **UP** or **DOWN**.
- Press **SET** to confirm the new value.

SWITCHING THE DEVICE ON/OFF

Press **UP** for more than 3 sec. The control and defrost algorithms are now disabled and the Instrument displays the message “OFF” alternating with the temperature read by the set probe.

MANUAL DEFROST

Press for **DOWN** more than 3 sec (the defrost starts only the temperature conditions are valid).

CONTINUOUS CYCLE

Press **UP** and **DOWN** together for more than 3 sec.

ACCESS AND SETTING TYPE F (FREQUENT) AND TYPE C (CONFIGURATION) PARAMETERS

1. Press **SET** for 3 sec (the display will show “PS”).
2. • To access the type F and C parameter menu, enter the password “22” using **UP/DOWN**, press **SET** to confirm.
• To access the F parameter menu only, press **SET** (without entering the password).
3. Scroll inside the parameter menu using **UP/DOWN**.
• To display/set the values of the parameter displayed, press **SET**, then **UP/DOWN** and finally **SET** to confirm the changes (returning to the parameter menu).

To save all the new values and exit the parameter menu, press **SET** for 3 sec.

To exit the menu without saving the changed values (exit by timeout) do not press any button for at least 60 sec.

MECHANICAL CONTROLLER INSTRUCTIONS

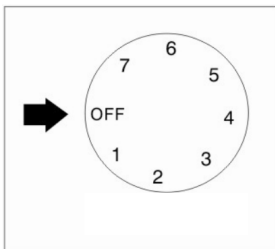

OFF: shut the compressor off.

Temperature range from 7 (coldest) to 1 (warmest).

CAUTION: setting the temperature control to the coldest setting may cause the evaporator coil to freeze and ice up. This will eventually result in a warmer cabinet temperature.

Cleaning and Maintenance

Condensers accumulate dirt and dust and require cleaning every 30 days. Dirty condensers result in compressor failure, product loss, and lost sales -- which are not covered by warranty.

Cleaning and Maintenance

Air is pulled through the condenser continuously along with dust, lint, grease, etc. If you keep the condenser clean you will minimize your service expense and lower your electrical costs. The condenser requires scheduled cleaning every days or as needed. A dirty condenser can result in non-warranted part and compressor failures and product loss.

Proper cleaning involves removing debris from the condenser by using a soft brush or vacuuming the condenser with a shop vac or using Co2, nitrogen or pressurized air.

If you cannot remove the debris adequately please call your refrigeration service company.

On most of the reach-in units the condenser is accessible at the rear of the unit. You must remove the cabinet grill to expose the condenser. The condenser looks like a group of vertical fins. You need to be able to see through the condenser for the unit to function at maximum capacity. Do not place filter material in front of condensing coil. This material blocks air flow to the coil which is similar to having a dirty coil.

CLEANING THE CONDENSER COIL

Required tools:

- Phillips screwdriver.
- Stiff bristle brush.
- Adjustable wrench.

When using electrical appliances basic safety precautions should be followed:

- Disconnect power to unit.
- Take off lower grill assembly by removing all screws.
- Remove bolts anchoring compressor assembly to frame rails and carefully slide out -- tube connections are flexible.
- Clean off accumulated dirt from condensing coil with the stiff bristle brush.
- Lift cardboard cover above fan at plastic plugs and carefully clean condenser coil and fan blades.
- After brushing condenser coil, vacuum dirt from coil and interior floor.
- Replace cardboard cover, carefully slide compressor assembly back into position and replace bolts.
- Reinstall louver assembly onto unit with appropriate fasteners and clips. Tighten all screws.
- Connect unit to power and check to see if condenser is running.

STAINLESS STEEL CARE AND CLEANING

Recommended cleaners for stainless steel:

- Soap, ammonia and detergent medallion applied with a soft cloth or sponge for routine cleaning.
- Arcal 20, Loc-O-Nu Ecoshine provide a barrier film for fingerprints and smears.
- Cameo, Talc, Zud First Impression is for stubborn stains and discoloration. Rub in direction of polish lines.
- Easy-off and De-Grease It oven aid are excellent for removals on all finishes for grease-fatty acids, blood and burnt-on foods.

Cleaning and Maintenance

- Any good commercial detergent can be applied with a sponge or soft cloth to remove grease and oil.
- Benefit, Super Sheen, Sheila Shine are good for restoration/passiveness.

CAUTION: do not use any steel wool, abrasive or chlorine based products to clean stainless steel surfaces.

STAINLESS STEEL ENEMIES

There are three basic items that can break down stainless steel's passivity layer and allow corrosion to occur.

1. Scratches from wire brushes, metal scrapers and steel pads are just a few examples of items that can be abrasive to stainless steel's surface.
2. Deposits left on stainless steel can leave spots. Hard water can leave spots. Hard water that is heated can leave deposits if left to sit for too long. These deposits can cause the passive layer to break down and rust stainless steel. All deposits left from food prep or service should be removed as quickly as possible.
3. Chlorides are present in table salt, food and water. Household and industrial cleaners are the worst type of chlorides to use.

8 Steps that can help prevent rust on stainless steel

1. Use the correct cleaning tools. Use non-abrasive tools when cleaning your stainless steel products. The stainless steel's passive layer will not be harmed by soft cloths and plastic scouring pads.
2. Clean along the polish lines. Polish lines or grain are visible on some stainless steel. Always scrub parallel to visible lines. Use a plastic scouring pad or soft cloth when grain is not visible.
3. Use alkaline, alkaline chlorinated or non-chloride containing cleaners. While many traditional cleaners are loaded with chlorides, the industry is providing an ever increasing choice of non-chloride cleaners. If unsure of chloride content contact the cleaner supplier. If present cleaner contains chlorides, ask for an alternative. Avoid cleaners containing quaternary salts as they can attack stainless steel causing pitting and rusting.
4. Water treatment. To reduce deposits, use soft water whenever possible. Installation of certain filters can be an advantage. Contact a treatment specialist about proper water treatment.
5. Maintain cleanliness of food equipment. Use cleaners at recommended strength(alkaline, alkaline chlorinated or non-chloride). Avoid buildup of hard stains by cleaning frequently.
6. When using chlorinated cleaners you must rinse and wipe dry immediately. It is better to wipe standing cleaning agents and water as soon as possible. All stainless steel equipment to air dry. Oxygen helps maintain the passivity film on stainless steel.
7. Hydrochloric acid (muriatic acid) should never be used on stainless steel.
8. Regularly restore/clean stainless steel.

KEG BEER LINE CLEANING

1. Tools needed.
2. Pour cleaning solution and water into the pump bottle and connect it to the beer line.
3. Place a bucket under the faucet and open the beer faucet. Pump to remove the cleaning solution and water. Continue to pump until all cleaning solution has exited. You can also fill the line and let it soak then run through the line. After you have run the cleaning solution through, open the bottle and fill with water. Repeat water rinsing until the line is free of cleaning chemicals.

Parts Breakdown

Model **BB-CN-0012-GH** 50058

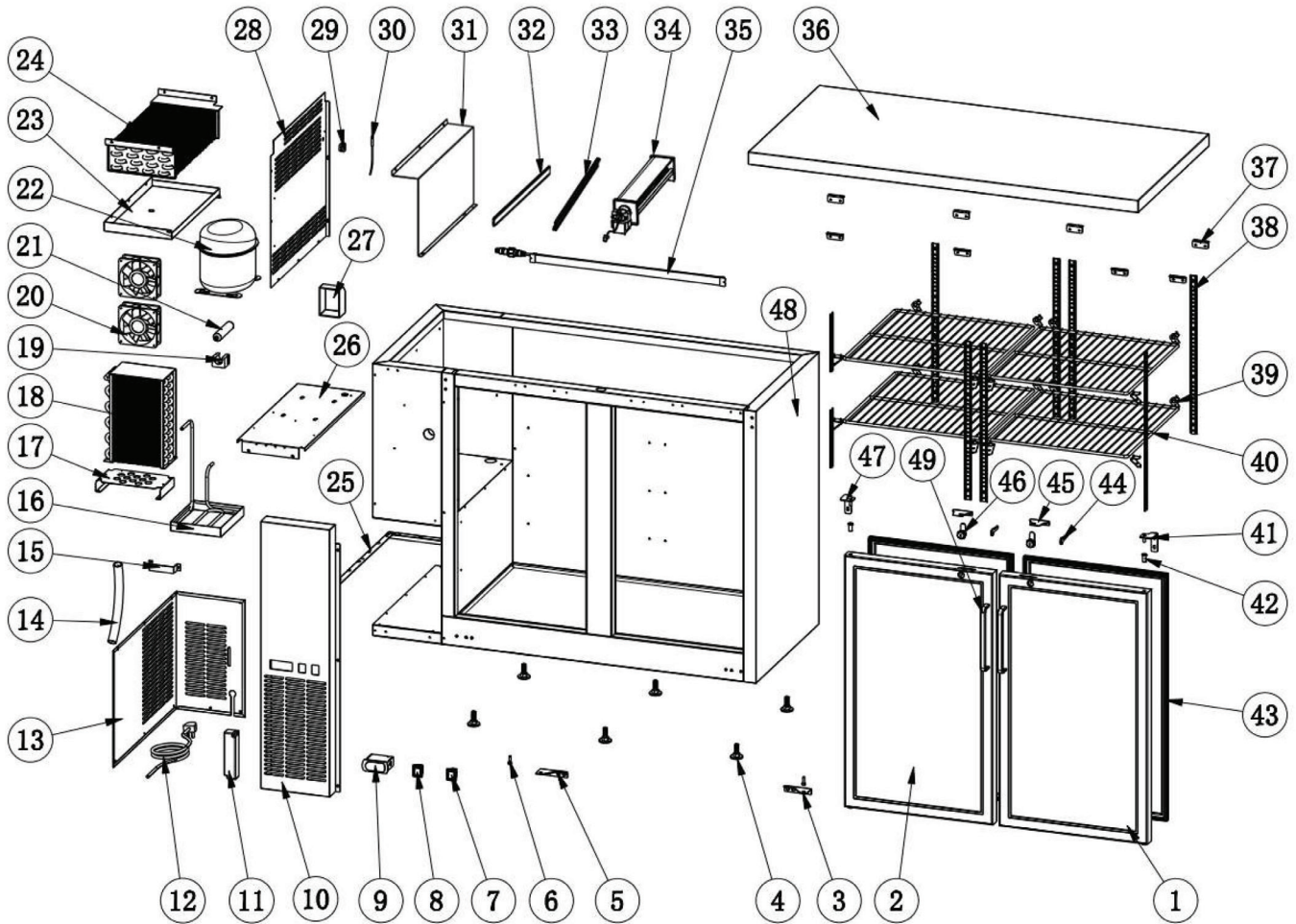



Parts Breakdown

Model BB-CN-0012-GH 50058

Item No.	Description	Position	Item No.	Description	Position	Item No.	Description	Position
AA357	Right Glass Door for 50058	1	AF778	Condenser Installation Board for 50058	17	AM180	Evaporator Fan Motor for 50058	34
AA358	Left Glass Door for 50058	2	AP021	Condenser for 50058	18	68296	LED Light for 50058	35
AA359	Bottom Right Hinge for 50058	3	AB595	Filter Fixer for 50058	19	AF821	Top Board for 50058	36
AA185	Leveling Feet for 50058	4	AA128	Condenser Fan Motor for 50058	20	AF764	Top Board Fixer for 50058	37
AA360	Bottom Left Hinge for 50058	5	AA371	Filter for 50058	21	AF176	K Strip-4 Holes for 50058	38
AA361	Bottom Hinge Axis for 50058	6	AF088	Compressor for 50058	22	26884	K Clip for 50058	39
AA124	Power Switch for 50058	7	AI396	Inner Drain Pan for 50058	23	AA386	Shelf for 50058	40
AA362	LED Light Switch for 50058	8	37686	Evaporator for 50058	24	AA436	Upper Right Hinge for 50058	41
27185	Carel Controller for 50058	9	AF780	Fixed Mounts for Back Grill for 50058	25	AA388	Axis Cover for 50058	42
AF776	Control Panel for 50058	10	AF781	Compressor Installation Board for 50058	26	AA389	Gasket for 50058	43
AM179	LED Power Supply for 50058	11	AF820	Evaporator Cover for 50058	28	AA390	Key for 50058	44
AA365	Power Cord for 50058	12	AA378	Temperature Probe Fixer for 50058	29	AF761	Lock Plate for 50058	45
AF777	Back Grill for 50058	13	AA379	Temperature Probe for 50058	30	AA392	Lock for 50058	46
AA216	Drain Tube for 50058	14	AI398	Inst Sheet for Evaporator for 50058	31	AF786	Upper Light Hinge for 50058	47
AB974	Handle for Installation Board for 50058	15	AP022	Sponge for 50058	32	AA395	Glass Door Handle for 50058	49
AF087	Outer Drain Pan for 50058	16	AL936	Evaporator Fan Cover for 50058	33			

Parts Breakdown

Model BB-CN-0016-GH 50060

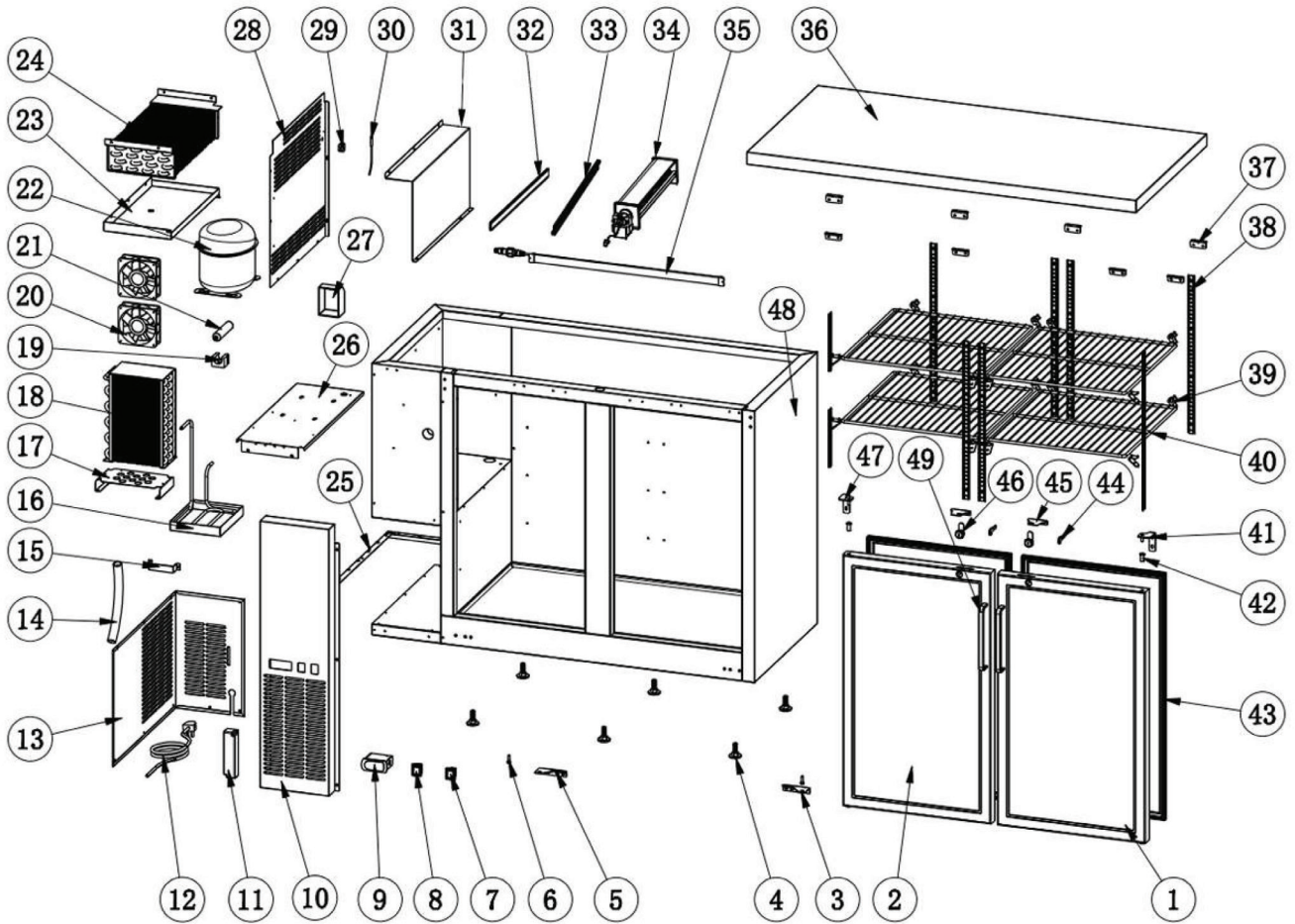

Parts Breakdown

Model BB-CN-0016-GH 50060

Item No.	Description	Position	Item No.	Description	Position	Item No.	Description	Position
AA462	Right Glass Door for 50060	1	AF778	Condenser Installation Board for 50060	17	AM180	Evaporator Fan Motor for 50060	34
AA420	Left Glass Door for 50060	2	AP021	Condenser for 50060	18	68296	LED Light for 50060	35
AA359	Bottom Right Hinge for 50060	3	AB595	Filter Fixer for 50060	19	AF822	Top Board for 50060	36
AA185	Leveling Feet for 50060	4	AA128	Condenser Fan Motor for 50060	20	AF764	Top Board Fixer for 50060	37
AA360	Bottom Left Hinge for 50060	5	AA371	Filter for 50060	21	AF176	K Strip-4 Holes for 50060	38
AA361	Bottom Hinge Axis for 50060	6	AF088	Compressor for 50060	22	26884	K Clip for 50060	39
AA124	Power Switch for 50060	7	AI396	Inner Drain Pan for 50060	23	AA435	Shelf for 50060	40
AA362	LED Light Switch for 50060	8	37686	Evaporator for 50060	24	AA436	Upper Right Hinge for 50060	41
27185	Carel Controller PYGX1Z0501 for 50060	9	AF780	Fixed Mounts for Back Grill for 50060	25	AA388	Axis Cover for 50060	42
AF776	Control Panel for 50060	10	AF781	Compressor Installation Board for 50060	26	37719	Glass Door Gasket for 50060	43
AM179	LED Power Supply for 50060	11	AF820	Evaporator Cover for 50060	28	AA390	Key for 50060	44
AA365	Power Cord for 50060	12	AA378	Temperature Probe Fixer for 50060	29	AF761	Lock Plate for 50060	45
AF777	Back Grill for 50060	13	AA379	Temperature Probe for 50060	30	AA392	Lock for 50060	46
AA216	Drain Tube for 50060	14	AI398	Inst Sheet for Evaporator for 50060	31	AF786	Upper Light Hinge for 50060	47
AB974	Handle for Installation Board for 50060	15	AP022	Sponge for 50060	32	AA395	Glass Door Handle for 50060	49
AF087	Outer Drain Pan for 50060	16	AL936	Evaporator Fan Cover for 50060	33			

Parts Breakdown

Model **BB-CN-0020-GH** 50062

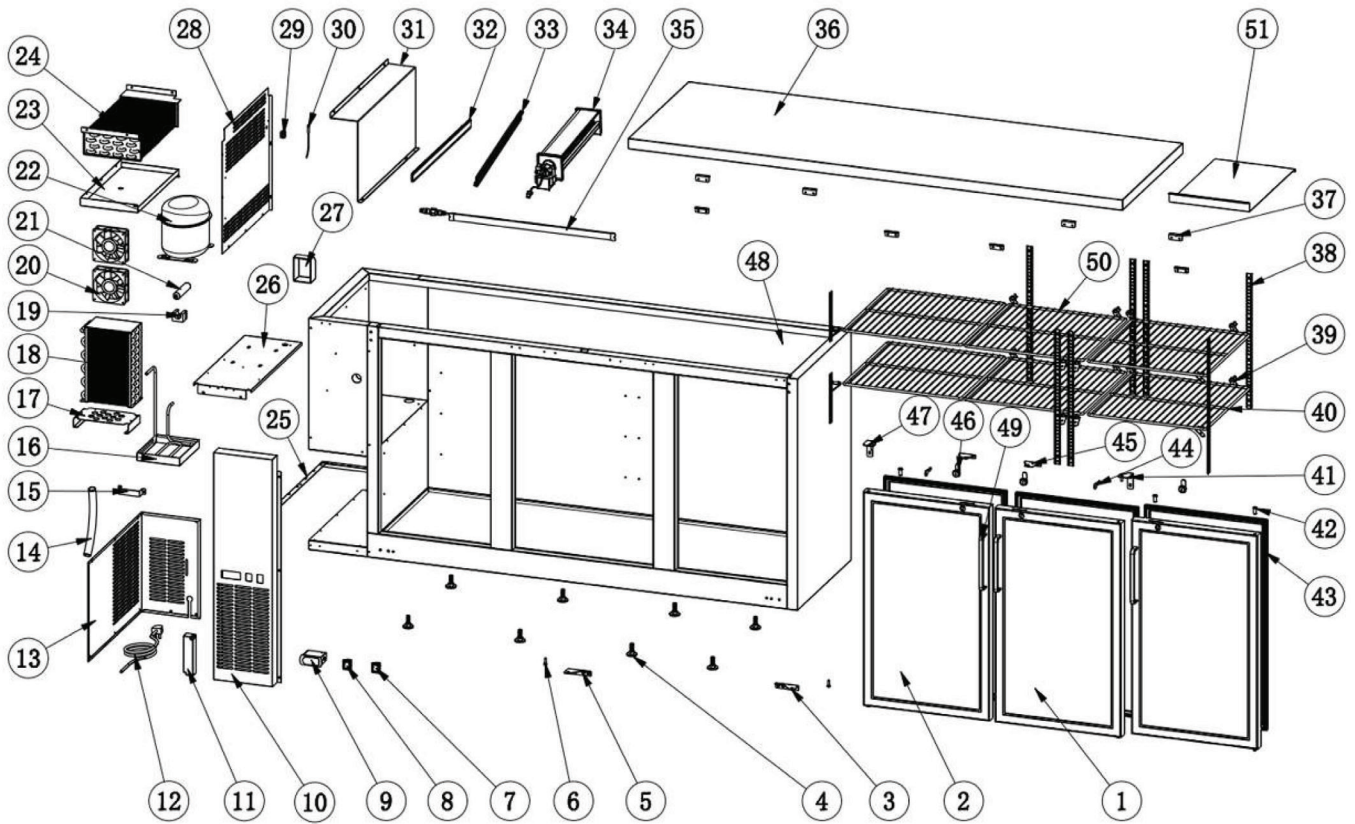

Parts Breakdown

Model BB-CN-0020-GH 50062

Item No.	Description	Position	Item No.	Description	Position	Item No.	Description	Position
47662	Right Glass Door for 50062	1	AP021	Condenser for 50062	18	AF824	Top Board for 50062	36
AA463	Left Glass Door for 50062	2	AB595	Filter Fixer for 50062	19	AF764	Top Board Fixer for 50062	37
AA359	Bottom Right Hinge for 50062	3	AA128	Condenser Fan Motor for 50062	20	AF176	K Strip-4 Holes for 50062	38
AA185	Leveling Feet for 50062	4	AA371	Filter for 50062	21	26884	K Clip for 50062	39
AA360	Bottom Left Hinge for 50062	5	AF088	Compressor for 50062	22	AF804	Shelf/Left and Right for 50062	40
AA361	Bottom Hinge Axis for 50062	6	AI396	Inner Drain Pan for 50062	23	AA436	Upper Right Hinge for 50062	41
AA124	Power Switch for 50062	7	37686	Evaporator for 50062	24	AA388	Axis Cover for 50062	42
AA362	LED Light Switch for 50062	8	AF780	Fixed Mounts for Back Grill for 50062	25	AA480	Gasket for 50062	43
27185	Carel Controller PYGX1Z0501 for 50062	9	AF781	Compressor Installation Board for 50062	26	AA390	Key for 50062	44
AF776	Control Panel for 50062	10	AF823	Evaporator Cover for 50062	28	AF761	Lock Plate for 50062	45
AM179	LED Power Supply for 50062	11	AA378	Temperature Probe Fixer for 50062	29	AA392	Lock for 50062	46
AA365	Power Cord for 50062	12	AA121	Temperature Sensor of Cabinet Inside for 50062	30	AF786	Upper Light Hinge for 50062	47
AF777	Back Grill for 50062	13	AI398	Inst Sheet for Evaporator for 50062	31	AA395	Glass Door Handle for 50062	49
AA216	Drain Tube for 50062	14	AP022	Sponge for 50062	32	AA484	Middle Shelf for 50062	50
AB974	Handle for Installation Board for 50062	15	AL936	Evaporator Fan Cover for 50062	33	AF805	Air Deflector for 50062	51
AF087	Outer Drain Pan for 50062	16	AM180	Evaporator Fan Motor for 50062	34			
AF778	Condenser Installation Board for 50062	17	68296	LED Light for 50062	35			

Parts Breakdown

Model BB-CN-0012-SH 50057

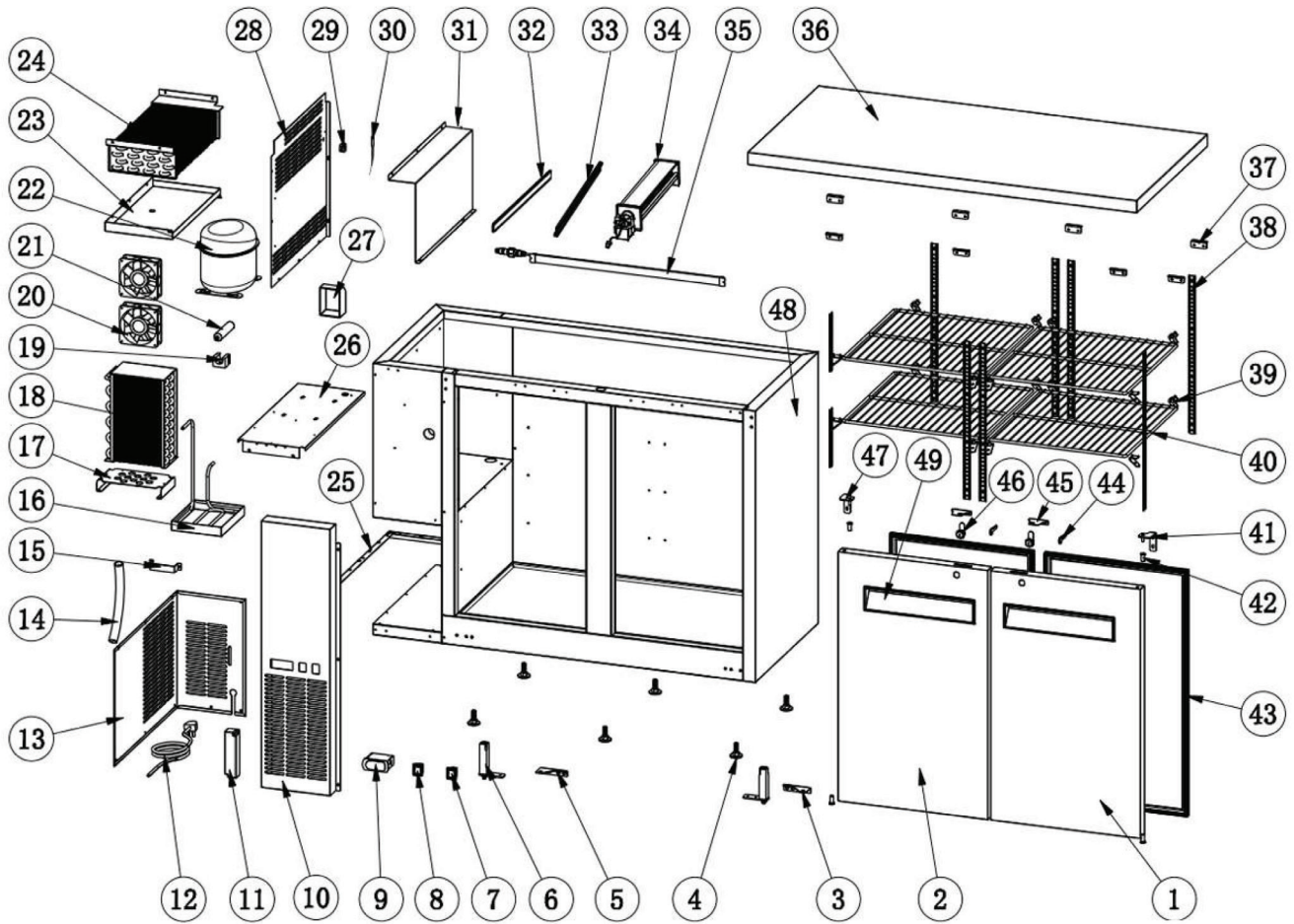

Parts Breakdown

Model BB-CN-0012-SH 50057

Item No.	Description	Position	Item No.	Description	Position	Item No.	Description	Position
AF774	Right Door for 50057	1	AF778	Condenser Installation Board for 50057	17	AM180	Evaporator Fan Motor for 50057	34
AF775	Left Door for 50057	2	AP021	Condenser for 50057	18	68296	LED Light for 50057	35
AA359	Bottom Right Hinge for 50057	3	AB595	Filter Fixer for 50057	19	AF821	Top Board for 50057	36
AA185	Leveling Feet for 50057	4	AA128	Condenser Fan Motor for 50057	20	AF764	Top Board Fixer for 50057	37
AA360	Bottom Left Hinge for 50057	5	AI968	Filter for 50057	21	AP025	K Strip for 50057	38
AA398	Bottom Hinge Axis for 50057	6	AF088	Compressor for 50057	22	26884	K Clip for 50057	39
AA124	Power Switch for 50057	7	AI396	Inner Drain Pan for 50057	23	AA386	Shelf for 50057	40
AA362	LED Light Switch for 50057	8	37686	Evaporator for 50057	24	AA436	Upper Right Hinge for 50057	41
27185	Carel Controller PYGX1Z0501 for 50057	9	AF780	Fixed Mounts for Back Grill for 50057	25	AA388	Axis Cover for 50057	42
AP023	Control Panel for 50057	10	AF781	Compressor Installation Board for 50057	26	AA414	Gasket for 50057	43
AM179	LED Power Supply for 50057	11	AF820	Evaporator Cover for 50057	28	AA196	Key for 50057	44
AA365	Power Cord for 50057	12	AA378	Temperature Probe Fixer for 50057	29	AF761	Lock Plate for 50057	45
AP024	Back Grill for 50057	13	AA379	Temperature Probe for 50057	30	AA197	Lock for 50057	46
AA216	Drain Tube for 50057	14	AF783	Evaporator Fan Installation Board for 50057	31	AF786	Upper Light Hinge for 50057	47
AB974	Handle for Installation Board for 50057	15	AA962	Blade of Evaporator Fan Motor-Old Style for 50057	32	AA418	Door Handle for 50057	49
AF087	Outer Drain Pan for 50057	16	AL936	Evaporator Fan Cover for 50057	33			

Parts Breakdown

Model **BB-CN-0016-SH** 50059

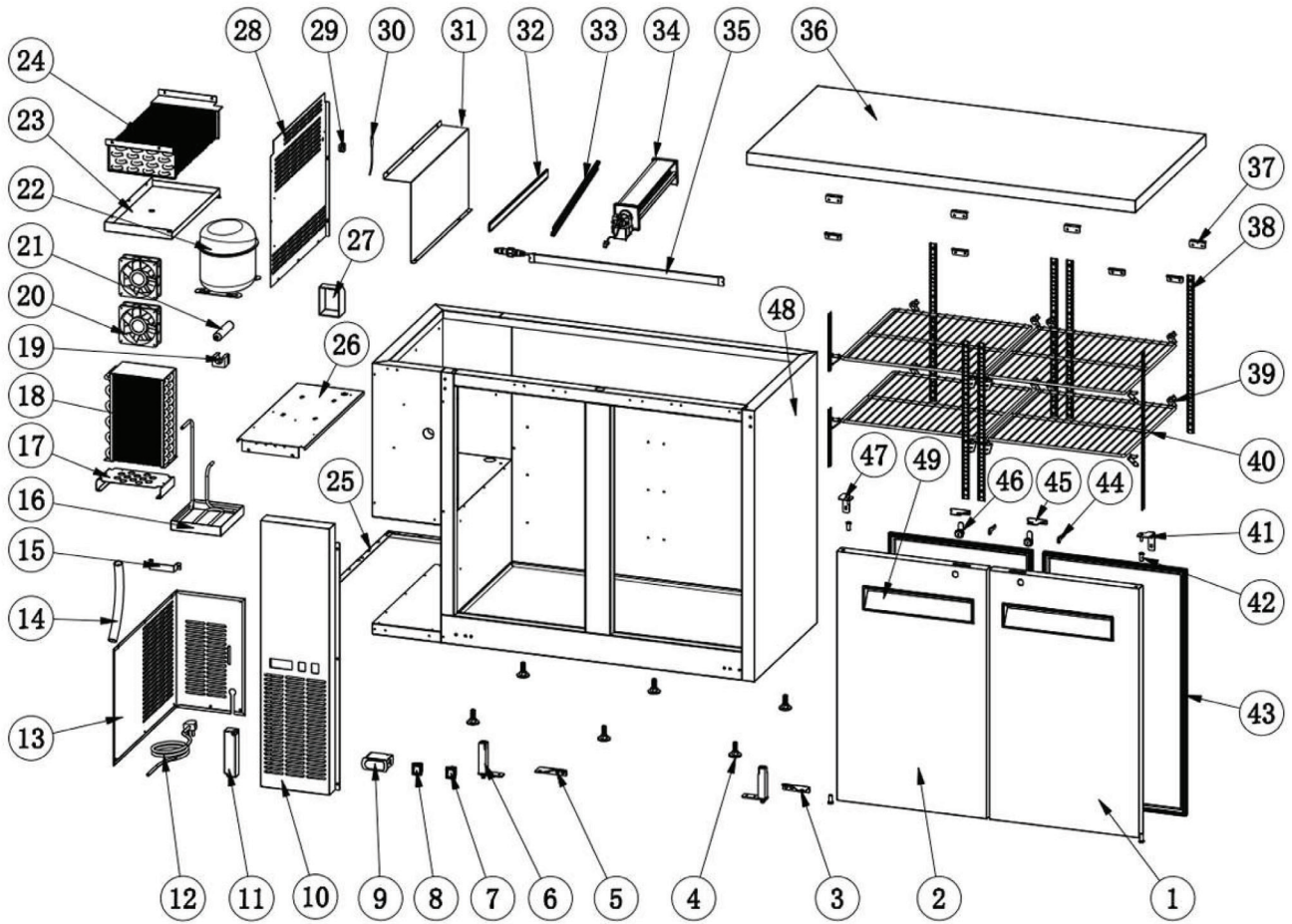

Parts Breakdown

Model BB-CN-0016-SH 50059

Item No.	Description	Position	Item No.	Description	Position	Item No.	Description	Position
AF795	Right Door for 50059	1	AF778	Condenser Installation Board for 50059	17	AM180	Evaporator Fan Motor for 50059	34
AF796	Left Door for 50059	2	AP021	Condenser for 50059	18	68296	LED Light for 50059	35
AA359	Bottom Right Hinge for 50059	3	AB595	Filter Fixer for 50059	19	AF797	Top Board for 50059	36
AA185	Leveling Feet for 50059	4	AA128	Condenser Fan Motor for 50059	20	AF764	Top Board Fixer for 50059	37
AA360	Bottom Left Hinge for 50059	5	AI968	Filter for 50059	21	AP025	K Strip for 50059	38
AA398	Bottom Hinge Axis for 50059	6	AF088	Compressor for 50059	22	26884	K Clip for 50059	39
AA124	Power Switch for 50059	7	AI396	Inner Drain Pan for 50059	23	AA435	Shelf for 50059	40
AA362	LED Light Switch for 50059	8	37686	Evaporator for 50059	24	AA436	Upper Right Hinge for 50059	41
27185	Carel Controller PYGX1Z0501 for 50059	9	AF780	Fixed Mounts for Back Grill for 50059	25	AA388	Axis Cover for 50059	42
AP023	Control Panel for 50059	10	AF781	Compressor Installation Board for 50059	26	AA458	Gasket for 50059	43
AM179	LED Power Supply for 50059	11	AF820	Evaporator Cover for 50059	28	AA196	Key for 50059	44
AA365	Power Cord for 50059	12	AA378	Temperature Probe Fixer for 50059	29	AF761	Lock Plate for 50059	45
AP024	Back Grill for 50059	13	AA379	Temperature Probe for 50059	30	AA197	Lock for 50059	46
AA216	Drain Tube for 50059	14	AF783	Evaporator Fan Installation Board for 50059	31	AF786	Upper Light Hinge for 50059	47
AB974	Handle for Installation Board for 50059	15	AA962	Blade of Evaporator Fan Motor-Old Style for 50059	32	AA418	Door Handle for 50059	49
AF087	Outer Drain Pan for 50059	16	AL936	Evaporator Fan Cover for 50059	33			

Parts Breakdown

Model BB-CN-0020-SH 50061

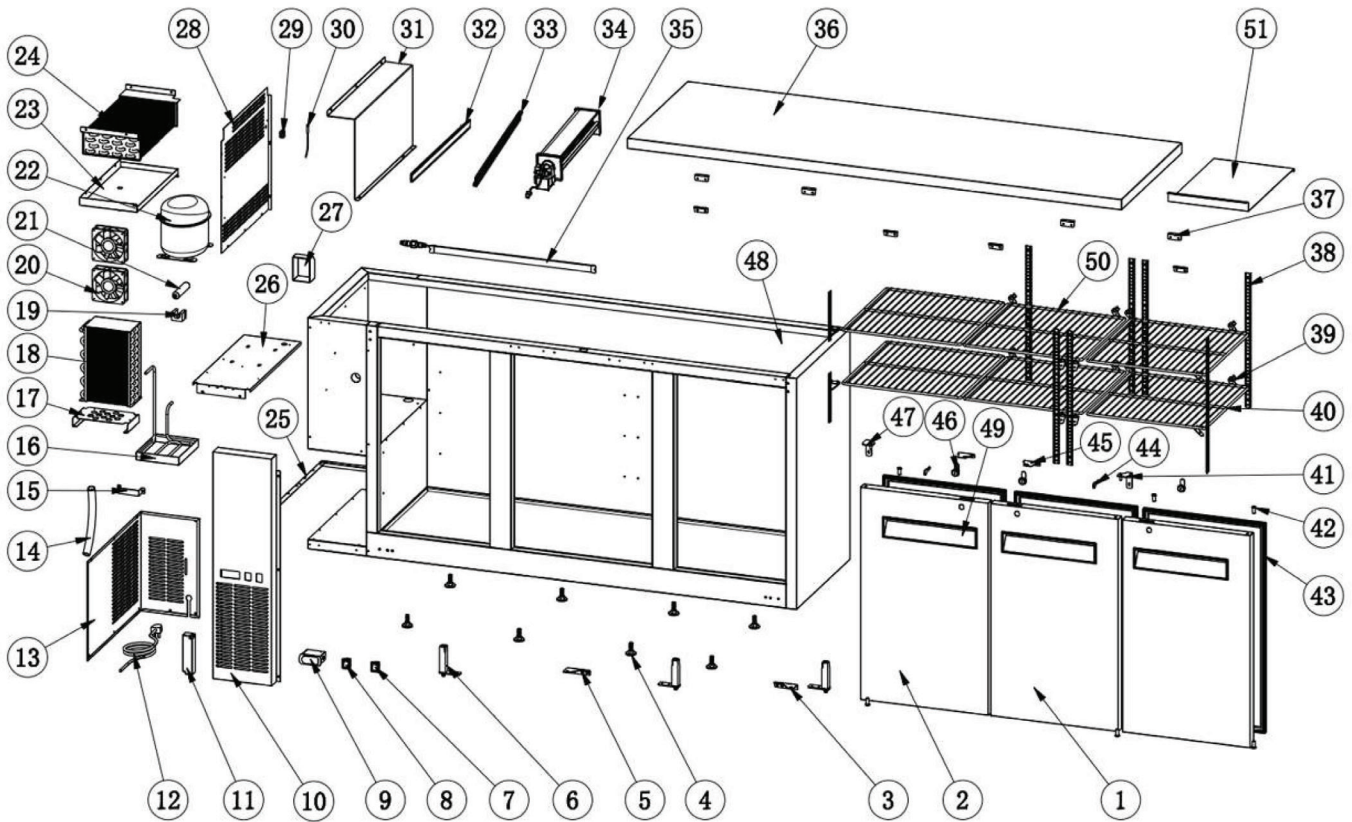



Parts Breakdown

Model BB-CN-0020-SH 50061

Item No.	Description	Position	Item No.	Description	Position	Item No.	Description	Position
AF800	Right Door for 50061	1	AP021	Condenser for 50061	18	AF824	Top Board for 50061	36
AF801	Left Door for 50061	2	AB595	Filter Fixer for 50061	19	AF764	Top Board Fixer for 50061	37
AA359	Bottom Right Hinge for 50061	3	AA128	Condenser Fan Motor for 50061	20	AP025	K Strip for 50061	38
AA185	Leveling Feet for 50061	4	AI968	Filter for 50061	21	26884	K Clip for 50061	39
AA360	Bottom Left Hinge for 50061	5	AF088	Compressor for 50061	22	AF804	Shelf/Left and Right for 50061	40
AA398	Bottom Hinge Axis for 50061	6	AI396	Inner Drain Pan for 50061	23	AA436	Upper Right Hinge for 50061	41
AA124	Power Switch for 50061	7	37686	Evaporator for 50061	24	AA388	Axis Cover for 50061	42
AA362	LED Light Switch for 50061	8	AF780	Fixed Mounts for Back Grill for 50061	25	37720	Solid Door Gasket for 50061	43
27185	Carel Controller PYGX1Z0501 for 50061	9	AF781	Compressor Installation Board for 50061	26	AA196	Key for 50061	44
AP023	Control Panel for 50061	10	AF823	Evaporator Cover for 50061	28	AF761	Lock Plate for 50061	45
AM179	LED Power Supply for 50061	11	AA378	Temperature Probe Fixer for 50061	29	AA197	Lock for 50061	46
AA365	Power Cord for 50061	12	AA121	Temperature Sensor of Cabinet Inside for 50061	30	AF786	Upper Light Hinge for 50061	47
AP024	Back Grill for 50061	13	AF783	Evaporator Fan Installation Board for 50061	31	AA418	Door Handle for 50061	49
AA216	Drain Tube for 50061	14	AA962	Blade of Evaporator Fan Motor-Old Style for 50061	32	AA484	Middle Shelf for 50061	50
AB974	Handle for Installation Board for 50061	15	AL936	Evaporator Fan Cover for 50061	33	AF805	Air Deflector for 50061	51
AF087	Outer Drain Pan for 50061	16	AM180	Evaporator Fan Motor for 50061	34			
AF778	Condenser Installation Board for 50061	17	68296	LED Light for 50061	35			

Electrical Schematics

Model BB-CN-0012-GH 50058

Model BB-CN-0012-SH 50057

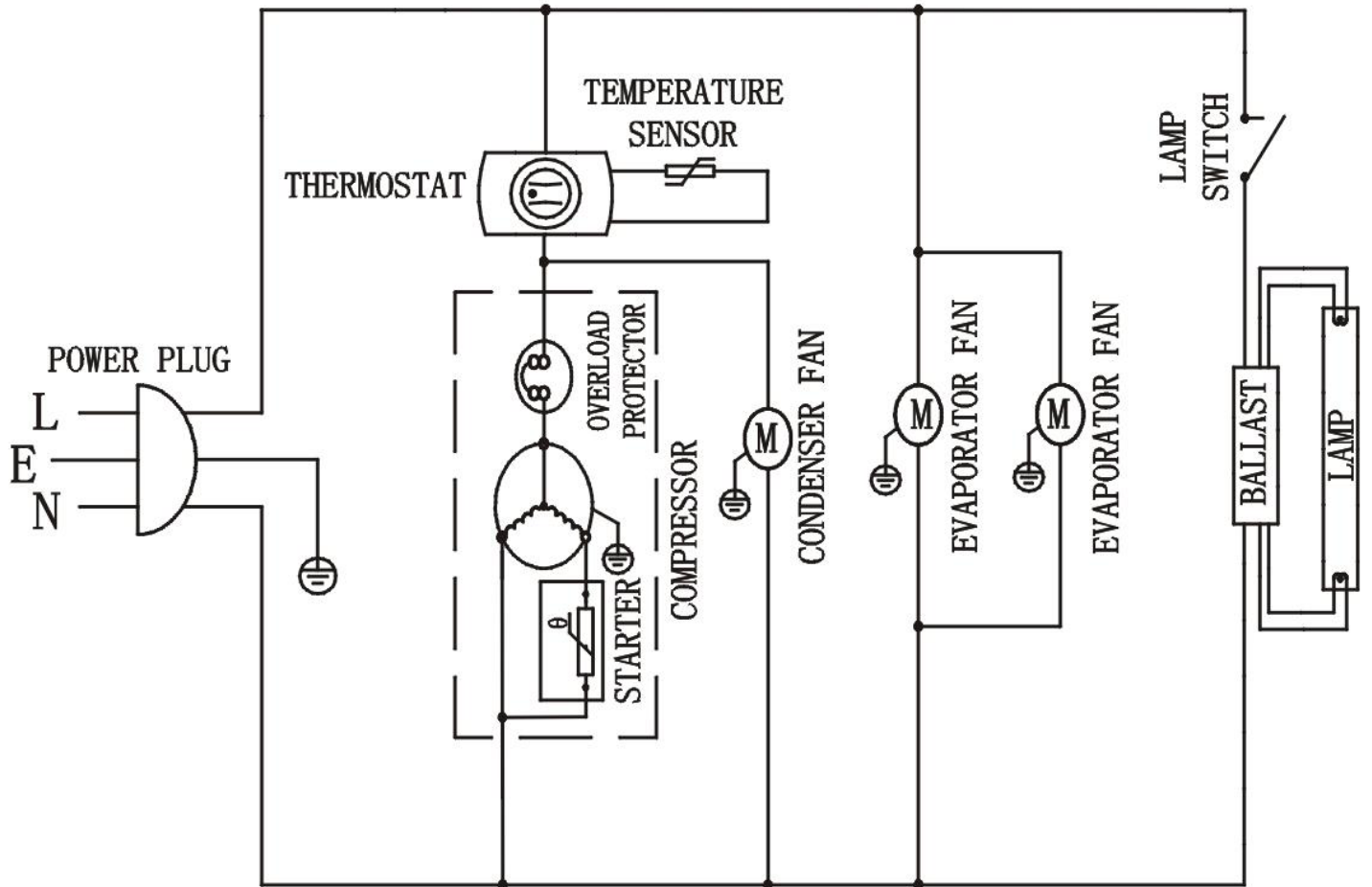

NEMA
5 - 15P
125VAC / 15 AMP

Electrical Schematics

Model BB-CN-0016-GH 50060

Model BB-CN-0016-SH 50059

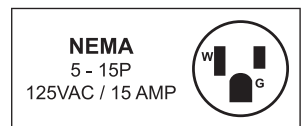
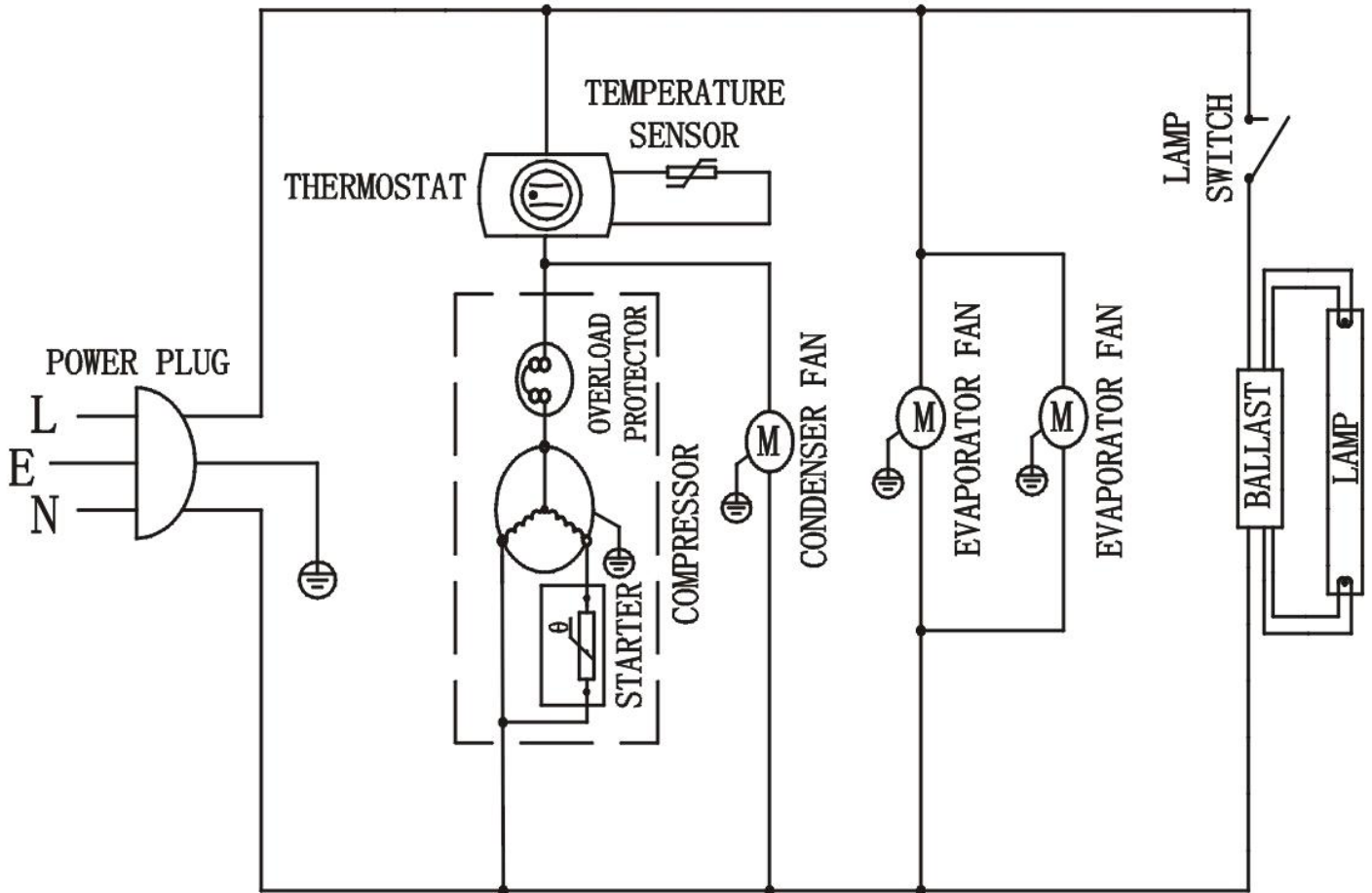

Electrical Schematics

Model BB-CN-0020-GH 50062

Model BB-CN-0020-SH 50061

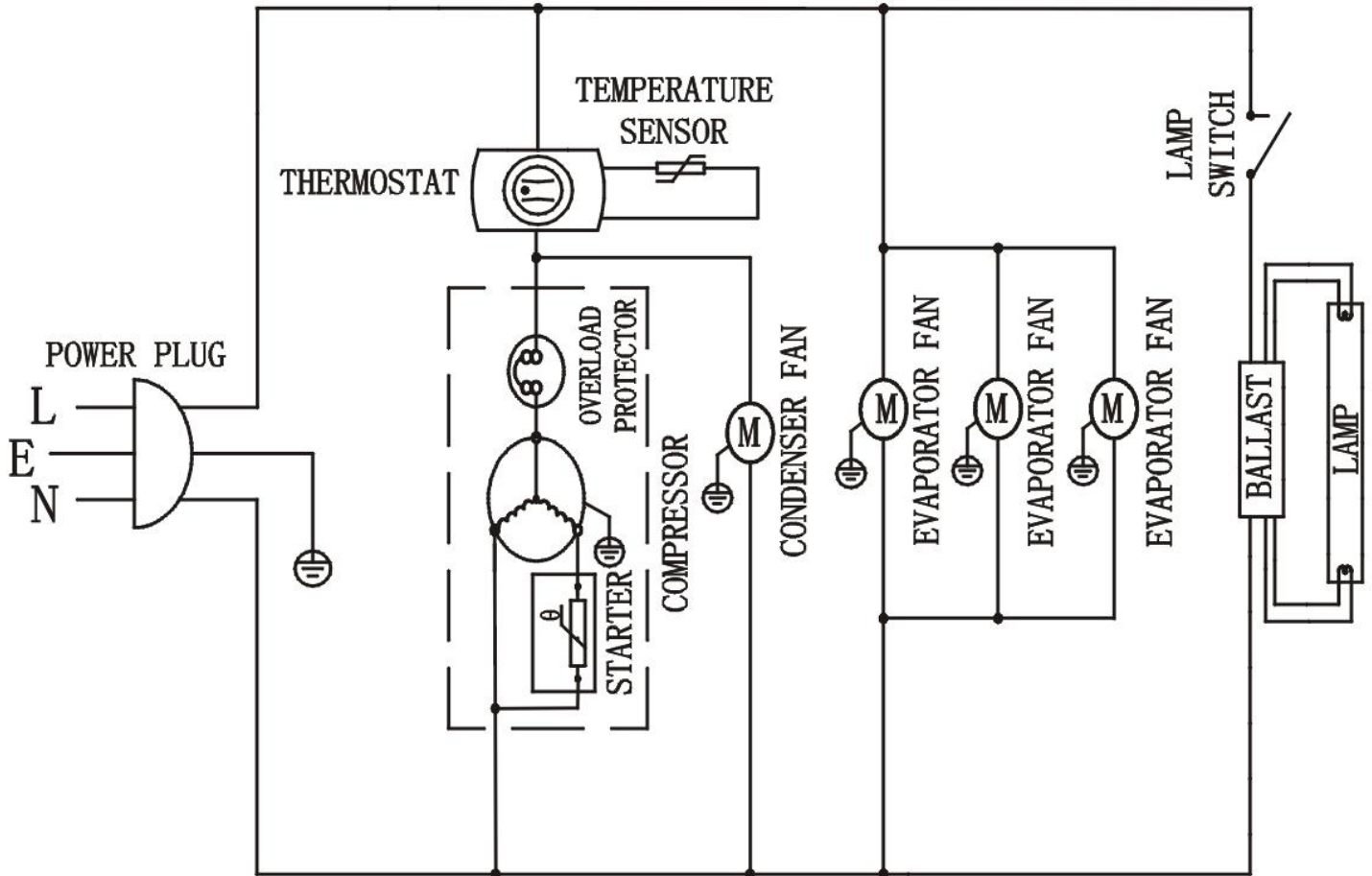

NEMA
5 - 15P
125VAC / 15 AMP



Warranty Registration

Thank you for purchasing an Omcan product. To register your warranty for this product, complete the information below, tear off the card at the perforation and then send to the address specified below. You can also register online by visiting:

Merci d'avoir acheté un produit Omcan. Pour enregistrer votre garantie pour ce produit, complétez les informations ci-dessous, détachez la carte au niveau de la perforation, puis l'envoyer à l'adresse spécifiée ci-dessous. Vous pouvez également vous inscrire en ligne en visitant:

Gracias por comprar un producto Omcan usted. Para registrar su garantía para este producto, complete la información a continuación, cortar la tarjeta en la perforación y luego enviarlo a la dirección indicada a continuación. También puede registrarse en línea en:

<https://omcan.com/warranty-registration/>

For mailing in Canada

Pour postale au Canada

Por correo en Canadá

OMCAN

PRODUCT WARRANTY REGISTRATION

3115 Pepper Mill Court,
Mississauga, Ontario
Canada, L5L 4X5

For mailing in the US

Pour diffusion aux États-Unis

Por correo en los EE.UU.

OMCAN

PRODUCT WARRANTY REGISTRATION

4450 Witmer Industrial Estates, Unit 4,
Niagara Falls, New York
USA, 14305

or email to: service@omcan.com



Purchaser's Information

Name: _____

Company Name: _____

Address: _____

Telephone: _____

City: _____ Province or State: _____ Postal or Zip: _____

Email Address: _____

Country: _____

Type of Company:

Restaurant Bakery Deli

Butcher Supermarket Caterer

Institution (*specify*): _____

Other (*specify*): _____

Dealer from which Purchased: _____

Dealer City: _____ Dealer Province or State: _____

Invoice: _____

Model Name: _____ Model Number: _____

Serial Number: _____

Machine Description: _____

Date of Purchase (MM/DD/YYYY): _____

Date of Installation (MM/DD/YYYY): _____

Would you like to extend the warranty? Yes No

Thank you for choosing Omcan | Merci d'avoir choisi Omcan | Gracias por elegir Omcan



Since 1951 Omcan has grown to become a leading distributor of equipment and supplies to the North American food service industry. Our success over these many years can be attributed to our commitment to strengthen and develop new and existing relationships with our valued customers and manufacturers. Today with partners in North America, Europe, Asia and South America, we continually work to improve and grow the company. We strive to offer customers exceptional value through our qualified local sales and service representatives who provide convenient access to over 6,500 globally sourced products.

Depuis 1951 Omcan a grandi pour devenir un des “leaders” de la distribution des équipements et matériel pour l’industrie des services alimentaires en Amérique du Nord. Notre succès au cours de ces nombreuses années peut être attribué à notre engagement à renforcer et à développer de nouvelles et existantes relations avec nos clients et les fabricants de valeur. Aujourd’hui avec des partenaires en Amérique du Nord, Europe, Asie et Amérique du Sud, nous travaillons continuellement à améliorer et développer l’entreprise. Nous nous efforçons d’offrir à nos clients une valeur exceptionnelle grâce à nos ventes locales qualifiées et des représentants de service qui offrent un accès facile à plus de 6500 produits provenant du monde entier.

Desde 1951 Omcan ha crecido hasta convertirse en un líder en la distribución de equipos y suministros de alimentos en América del Norte industria de servicios. Nuestro éxito en estos años se puede atribuir a nuestro compromiso de fortalecer y desarrollar nuevas relaciones existentes con nuestros valiosos clientes y fabricantes. Hoy con socios de América del Norte, Europa, Asia y América del Sur, que trabajan continuamente para mejorar y crecer la empresa. Nos esforzamos por ofrecer a nuestros clientes valor excepcional a través de nuestro local de ventas y representantes de los servicios que proporcionan un fácil acceso a más de 6,500 productos con origen a nivel mundial.

