



SERVING THE FOOD INDUSTRY SINCE 1951

27" Black Countertop Refrigerated Display with 3.5cu.ft. / 100L capacity - 110V, 170W

ITEM: 27155

MODEL: RS-CN-0100-E



Attractively display food merchandise and increase impulse sale.

Display your products brilliantly with our refrigerated showcase. The glass display makes sure that your customers have all round view of your refrigerated products.

This unit has a large capacity that let's you store and display many products at once, and this especially helpful for busy stores.

It uses the environment friendly R290 refrigerant. The digital temperature controller lets you control the product temperature, and also allows light control that illuminates the interior to highlight your products.

FEATURES:

- Comes with rear sliding doors, interior light, and glass windows on each side
- Designed to fit on table tops
- Fixed shelves
- Comes with two shelves; but can put max of 3 shelves



Telephone: 1-800-465-0234

Fax: (905) 607-0234

Email: sales@omcan.com

Website: www.omcan.com



Authorized Dealer

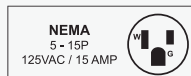

TECHNICAL DRAWING

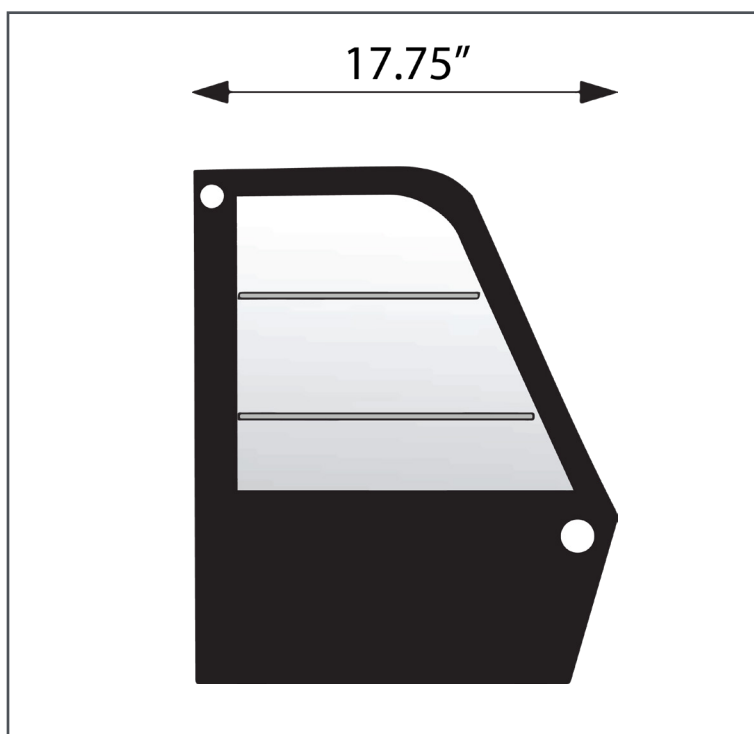
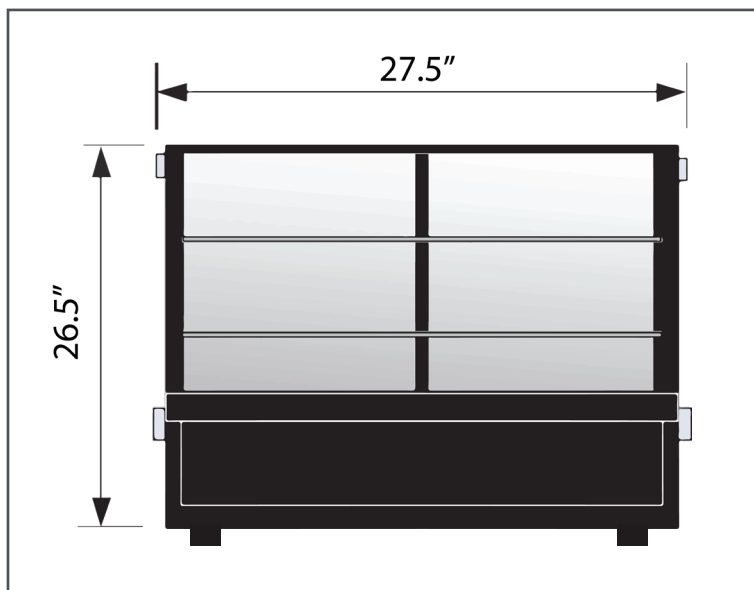

TECHNICAL SPECIFICATION

Item	27155
Model	RS-CN-0100-E
Capacity	3.5cu.ft. / 100L
Maximum Load	33lb. / 15kg.
Number of Doors	2 Sliding Doors
Number of Shelves	2-3
Shelf Size	12.25" x 24" / 311 x 610 mm
Shelf Material	Chrome
Interior Material	Plastic
Exterior Material	Plastic + Metal
Number of Casters	-
Power	170W
Lamp Power	2.88W
Amps	1.5A
Electrical	110V / 60Hz / 1Ph
Temperature Controller	Digital
Temperature Range	12° to 0°C / 54° to 32°F
Refrigerant	R290
Injection	40g
Type Of Climate	4
Insulation Material	NA
Defrosting	Automatic
Cooling System	Forced Air
Interior Dimensions (WDH)	25.75" x 15.3" x 15.5" / 654 x 389 x 394 mm
Net Weight	86.2 lb. / 39.1 kg.
Net Dimensions (WDH)	27.5" x 17.75" x 26.5" / 686 x 450 x 673 mm
Gross Weight	97 lb. / 44 kg.
Gross Dimensions (WDH)	30" x 21" x 31" / 762 x 533 x 787 mm